



Owner and Operational Manual

Model: _____
Serial Number: _____
Install Date: _____
Installed By: _____
Service Phone: _____
Sold By: _____



Please read this manual carefully before proceeding with installation. Your failure to follow any of these instructions or operating parameters may lead to personal injury or damage to the equipment and/or personal property. Do not use this water treatment system with water that is microbiologically unsafe or of unknown quality, without adequate disinfection before or after the system.

This water treatment system contains replaceable treatment components critical for effective performance. It is the user's responsibility to periodically test the product water to verify the system is performing satisfactorily. Failure to properly maintain this water treatment system may cause a health risk.

Save this manual for future reference



Table of Contents

SAFETY INFORMATION	3
AUTOTROL 255 VALVE CONTROL MODULE.....	4
SYSTEM REGENERATION CYCLES (7-CYCLE OPERATION)	5
INSTALLATION	6
DISINFECTION OF WATER CONDITIONERS.....	9
SODIUM OR CALCIUM HYPOCHLORITE	9
CALCIUM HYPOCHLORITE	9
PLACING CONDITIONER INTO OPERATION	9
HARDNESS SETTING.....	12
COMMON FEATURES.....	13
PREVENTIVE MAINTENANCE.....	14
REPLACEMENT PARTS FOR AUTOTROL BRAND 255 CONTROL.....	15
255 VALVE & TANK ADAPTER MODULE	16
REPLACEMENT PARTS	17
255 SERIES ACCESSORIES.....	18
TROUBLESHOOTING	19
VALVE TROUBLESHOOTING	19
260i TROUBLESHOOTING.....	20
VALVE SPECIFICATIONS	20
WATER TREATMENT SYSTEM WARRANTY	21

Safety Information

This water conditioner's control valve conforms to NSF/ANSI 44 and 61 for materials and structural integrity only. Generic systems were tested and certified by WQA as verified by the performance data sheet.

- Please review this entire Installation and Operation manual before installing unit.
- We recommend that this water conditioning unit be installed by a trained professional water treatment dealer. Follow all local codes for plumbing this unit.
- Follow local electrical codes. Install a correctly sized electrical bonding jumper between the inlet and outlet pipes when these devices are installed in metallic plumbing systems.
- Inspect this unit carefully for carrier shortage or shipping damage before beginning installation of unit.
- This system is not intended to be used for treating water that is microbiologically unsafe or of unknown quality without adequate disinfection before or after the system.
- This system is to be used only for potable water.
- Use only lead-free solder and flux, as required by federal and state codes, when installing soldered copper plumbing.
- Use caution when sweat joining metal pipes near this water conditioning system. Heat can adversely affect the plastic used in this system and bypass valve.
- Use only silicone grease for lubrication of this unit.
- Use only the power transformers supplied with this conditioning systems control valve unit.
- Do not allow this water conditioning unit to freeze. Damage from freezing will void this water conditioning unit's warranty.
- Do not store flammable or volatile chemicals near this water conditioning unit.
- For the purpose of plumbing system sizing, only the rated service (i.e. "Normal") flow and corresponding pressure loss may be used. The rated service flow rates are the flow rates at which the performance capabilities of these devices were evaluated.

Contact your local Professional Water Dealer for system service, and to obtain Autotrol brand replacement parts for this control valve unit.

Autotrol 255 Valve Control Module

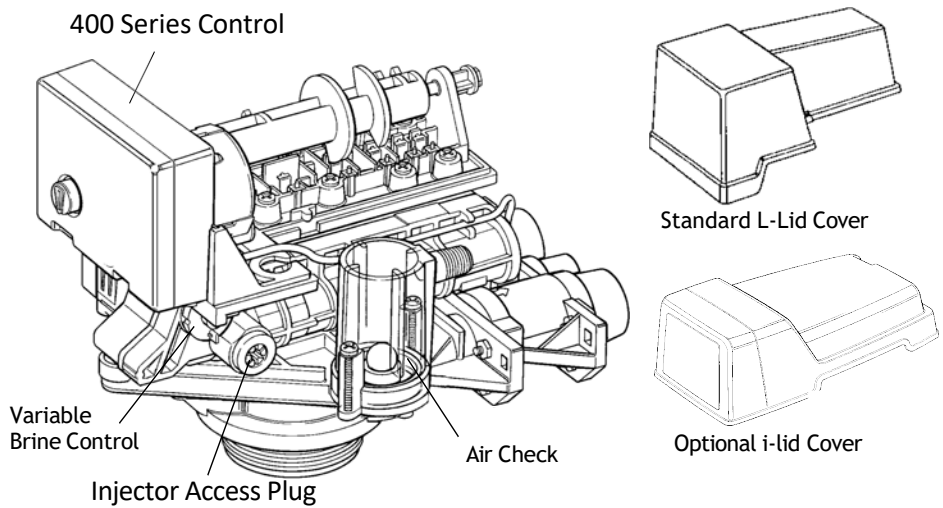

Tank Adapter Module

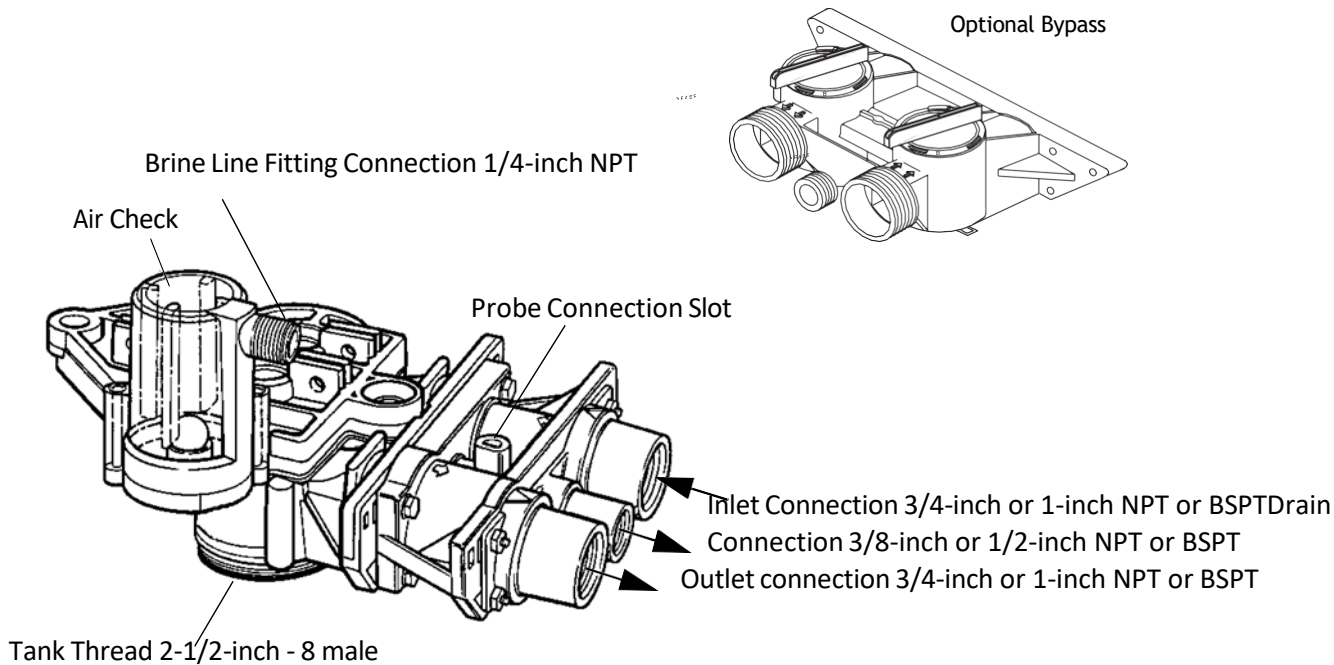

System Regeneration Cycles (7-Cycle Operation)

1. Service (Downflow) — Cycle C0:

Untreated water is directed down through the resin bed and up through the riser tube. The hardness ions attach themselves to the resin and are removed from the water. The water is conditioned as it passes through the resin bed.

2. Backwash (Upflow) — Cycles C1, C6:

The flow of water is reversed by the control valve and directed down the riser tube and up through the resin bed. During the backwash cycle, the bed is expanded and debris is flushed to the drain.

3. Brine/Slow Rinse (Downflow) — Cycles C3:

The control directs water through the brine injector and brine is drawn from the regenerant tank. The brine is then directed down through the resin bed and up through the riser tube to the drain. The hardness ions are displaced by sodium ions and are sent to the drain. The resin is regenerated during the brine cycle. Brine draw is completed when the air check closes.

4. Fast Rinse (Downflow) — Cycles C5, C7:

The control directs water down through the resin bed and up through the riser tube to the drain. Any remaining brine residual is rinsed from the resin bed.

5. Brine Refill (Downflow) — Cycle C8:

Brine refill occurs during a portion of the fast rinse cycle. Water is directed to the regenerant tank at a controlled rate, to create brine for the next regeneration.

6. Repressurize Cycle — (No Flapper Open), Cycle C4:

This cycle closes all flappers for a short time to allow the air and water to hydraulically balance in the valve before continuing the regeneration.

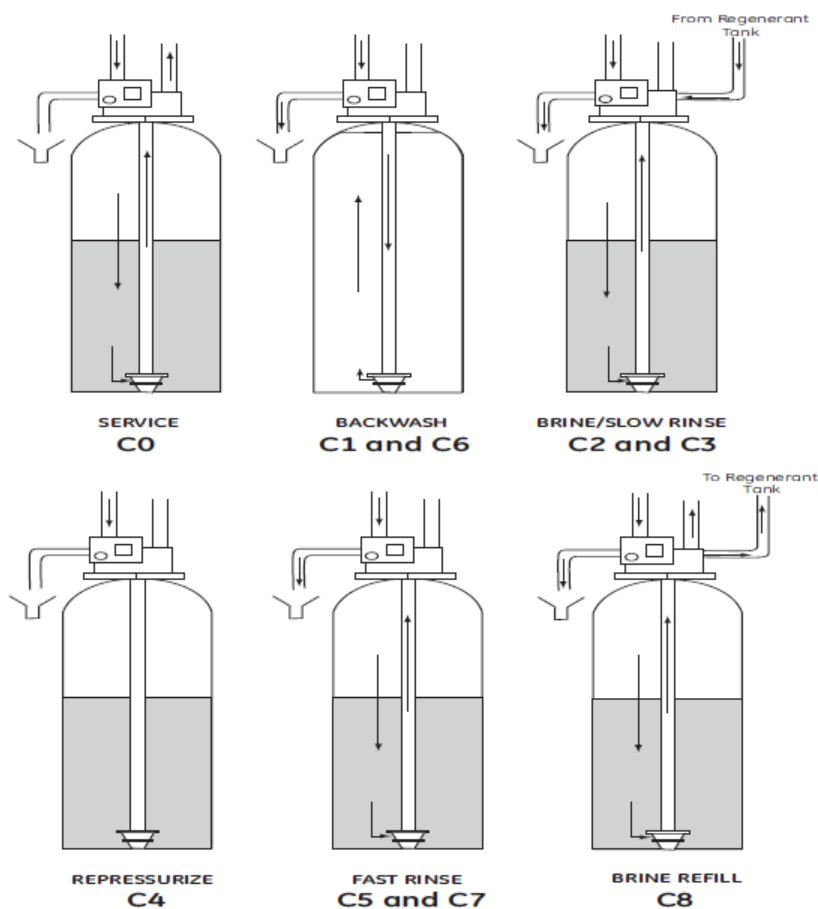

Installation

Figure 3 All plumbing must conform to local codes.

Inspect unit carefully for carrier shortage or shipping damage.

Location Selection

1. The distance between the unit and a drain should be as short as possible.
2. If it is likely that supplementary water treating equipment will be required, make certain adequate additional space is available.
3. Since salt must be added periodically to the brine tank, the location should be easily accessible.
4. Do not install any unit closer to a water heater than a total run of 10 feet (3 m) of piping between the outlet of the conditioner and the inlet to the heater. Water heaters can sometimes overheat to the extent they will transmit heat back down the cold pipe into the unit control valve. Hot water can severely damage the conditioner. A 10-foot (3-m) total pipe run, including bends, elbows, etc., is a reasonable distance to help prevent this possibility. A positive way to prevent hot water from flowing from heat source to the conditioner, in the event of a negative pressure situation, is to install a check valve in the soft water piping from the conditioner. **If a check valve is installed, make certain the water heating unit is equipped with a properly rated temperature and pressure safety relief valve. Also, be certain that local codes are not violated.**
5. Do not locate unit where it or its connections (including the drain and overflow lines) will ever be subjected to room temperatures under 34°F (1°C) or over 120°F (49°C).
6. Do not install unit near acid or acid fumes.
7. The use of resin cleaners in an unvented enclosure is not recommended.

Water Line Connection

The installation of a bypass valve system is recommended to provide for occasions when the water conditioner must be bypassed for hard water or for servicing.

The most common bypass systems are the Autotrol® Series 256 bypass valve (Figure 4) and plumbed-in globe valves (Figure 5). Though both are similar in function, the 256 Autotrol bypass offers simplicity and ease of operation.

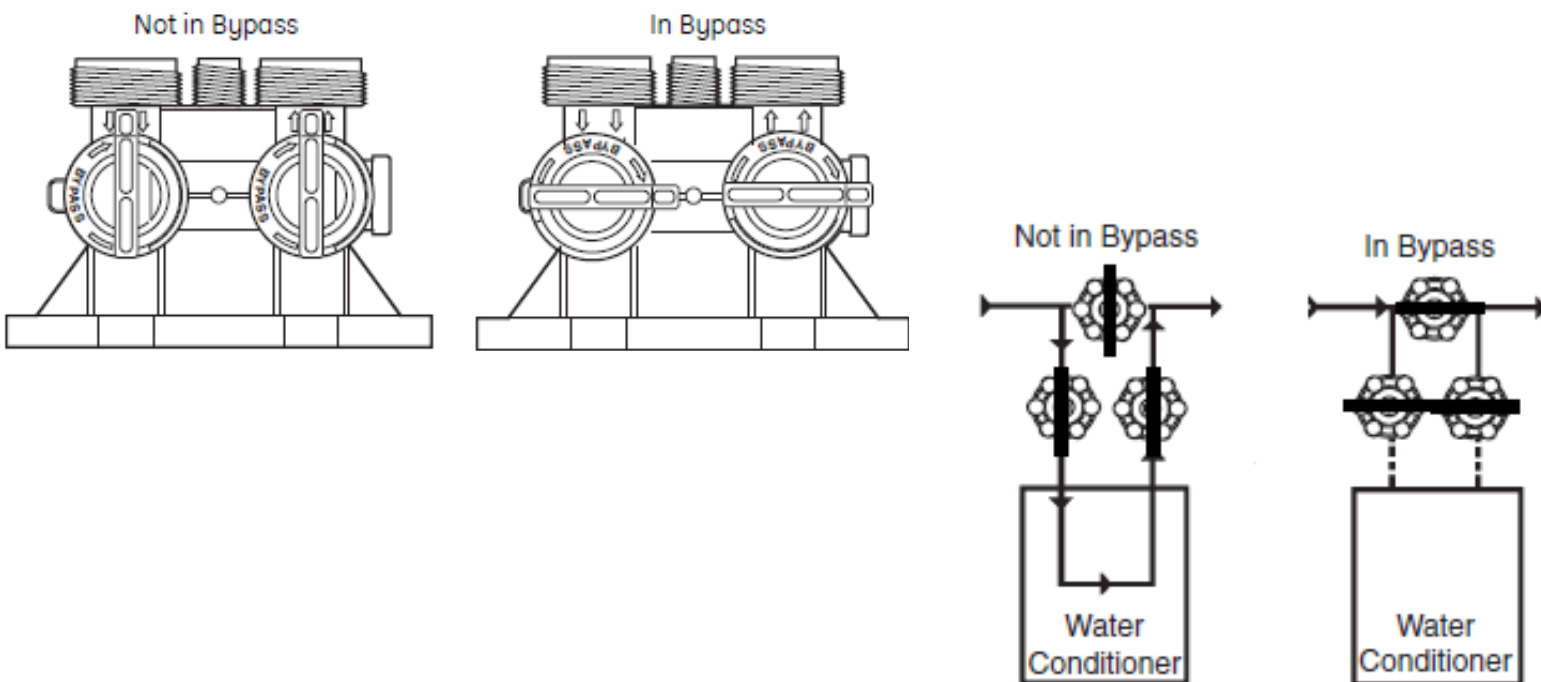

Drain Line Connection

1. Ideally located, the unit will be above and not more than 20 feet (6.1 m) from the drain. For such installations, use an appropriate adapter fitting (not supplied), to connect 1/2-inch (1.3-cm) plastic tubing to the drain line connection of the control valve.
2. If the unit is located more than 20 feet (6.1 m) from drain, use 3/4-inch (1.9-cm) tubing for runs up to 40 feet (12.2 m). Also, purchase appropriate fitting to connect the 3/4-inch tubing to the 1/2-inch NPT drain connection.
3. If the unit is located where the drain line must be elevated, you may elevate the line up to 6 feet (1.8 m) providing the run does not exceed 15 feet (4.6 m) and water pressure at conditioner is not less than 40 psi (2.76 bar). You may elevate an additional 2 feet (61 cm) for each additional 10 psi (0.69 bar).
4. Where the drain line is elevated but empties into a drain below the level of the control valve, form a 7-inch (18-cm) loop at the far end of the line so that the bottom of the loop is level with the drain line connection. This will provide an adequate siphon trap.
5. Where the drain empties into an overhead sewer line, a sink-type trap must be used.

IMPORTANT: Never insert drain line into a drain, sewer line or trap. Always allow an air gap between the drain line and the wastewater to prevent the possibility of sewage being back-siphoned into conditioner.

Note: Standard commercial practices have been expressed here. Local codes may require changes to these suggestions.

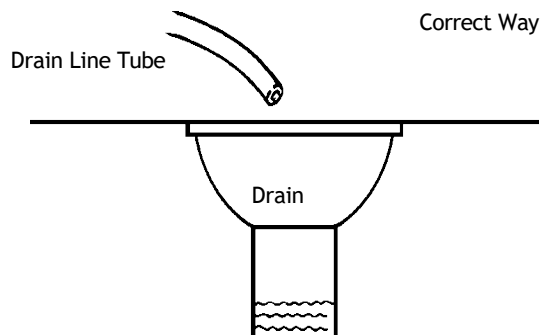

Brine Line Connection

It will be necessary to install the brine tube and line to a fitting installed on the air check. Teflon^{*} tape all threaded connections.

Be sure all fittings and connections are tight so that premature checking does not take place. Premature checking is when the ball in the air check falls to the bottom before all brine is drawn out of the brine tank. See **Placing Conditioner into Operation** section.

**Teflon is a registered trademark of E.I. DuPont de Nemours and Company, Inc.*

Overflow Line Connection

In the absence of a safety overflow and in the event of a malfunction, the BRINE TANK OVERFLOW will direct "overflow" to the

drain instead of spilling on the floor where it could cause considerable damage. This fitting should be on the side of the cabinet or brine tank.

To connect overflow, locate hole on side of brine tank. Insert overflow fitting (not supplied) into tank and tighten with plastic thumb nut and gasket as shown (Figure 7). Attach length of 1/2-inch (1.3-cm) I.D. tubing (not supplied) to fitting and run to drain. Do not elevate overflow line higher than 3 inches (7.6 cm) below bottom of overflow fitting. Do not tie into drain line of control unit. Overflow line must be a direct, separate line from overflow fitting to drain, sewer or tub. Allow an air gap as per drain line instructions (Figure 6).

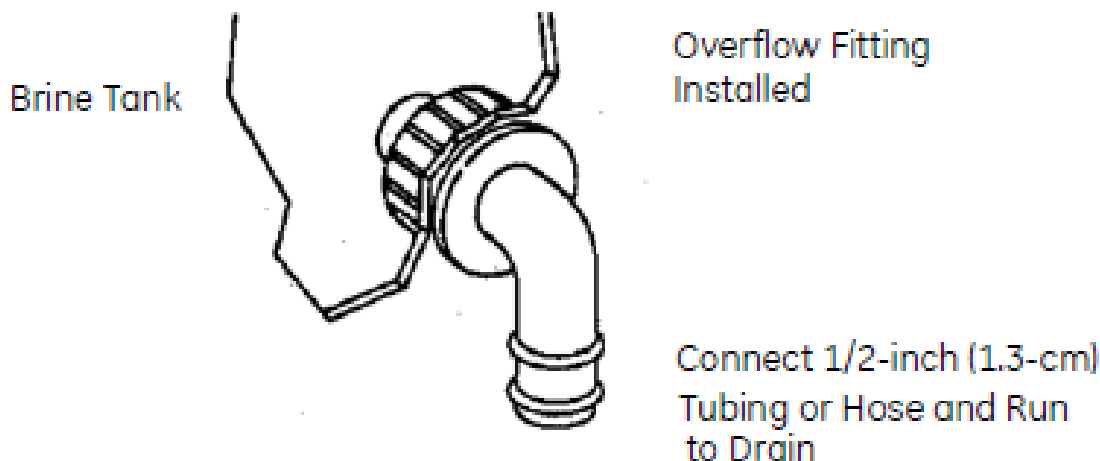

Low Voltage Transformer

Use only the included transformer for powering the 400 series timers. Connect the plug of the transformer secondary cable to the mating socket on the control.

Be certain that the transformer is plugged into a correct voltage source that is not controlled by a wall switch.

Increasing the Length of the Transformer Cord

If it is necessary to extend the length of the transformer cord, an optional 15-foot (4.6- m) extension is available.

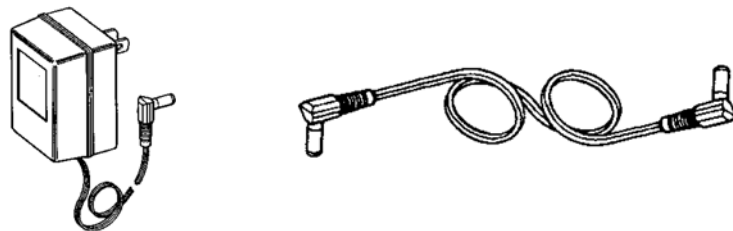

Disinfection of Water Conditioners

The materials of construction of the modern water conditioner will not support bacterial growth, nor will these materials contaminate a water supply. In addition, during normal use, a conditioner may become fouled with organic matter, or in some cases with bacteria from the water supply. This may result in an off-taste or odor in the water.

Thus, your conditioner may need to be disinfected after installation. Some conditioners will require periodic disinfection during their normal life. Consult your installing dealer for more information on disinfecting your conditioner.

Depending upon the conditions of use, the style of conditioner, the type of ion exchanger, and the disinfectant available, a choice can be made among the following methods.

Sodium or Calcium Hypochlorite

Application

These materials are satisfactory for use with polystyrene resins, synthetic gel zeolite, greensand and bentonites.

5.25% Sodium Hypochlorite

These solutions are available under trade names such as Clorox*. If stronger solutions are used, such as those sold for commercial laundries, adjust the dosage accordingly.

1. Dosage
 - a. Polystyrene resin; 1.2 fluid ounce per cubic foot.
 - b. Non-resinous exchangers; 0.8 fluid ounce per cubic foot.
2. Brine tank conditioners
 - a. Backwash the conditioner and add the required amount of hypochlorite solution to the brine well of the brine tank. The brine tank should have water in it to permit the solution to be carried into the conditioner.
 - b. Proceed with the normal regeneration.

Calcium Hypochlorite

Calcium hypochlorite, 70% available chlorine, is available in several forms including tablets and granules. These solid materials may be used directly without dissolving before use.

1. Dosage
 - a. Two grains (approximately 0.1 ounce) per cubic foot.
2. Brine tank conditioners
 - a. Backwash the conditioner and add the required amount of hypochlorite to the brine well of the brine tank. The brine tank should have water in it to permit the chlorine solution to be carried into the conditioner.
 - b. Proceed with the normal regeneration.

Placing Conditioner into Operation

Initial Start-Up

After the water conditioning system is installed, the conditioner should be disinfected before it is used to treat potable water. Refer to the **Disinfection of Water Conditioners** section in this manual. Complete the following steps to place the conditioner into operation:

1. Remove control valve cover.

Note: The following steps will require turning the indicator knob (Figure 11) to various positions. Insert a wide-blade screwdriver into arrow slot in indicator knob and press in firmly. With knob held in, rotate **COUNTERCLOCKWISE** only until arrow or knob points to desired position. Rotation is made much easier if you grasp the camshaft with your free hand and turn it at the same time. Then permit knob to spring back out.

2. Insert screwdriver into slot in indicator knob (Figure 11). Press in and rotate knob **COUNTERCLOCKWISE** until arrow points directly to the word **BACKWASH**.
3. Fill resin tank with water.
 - a. With water supply off, place the bypass valve(s) into the **"NOT IN BYPASS"** position.
 - b. Open water supply valve very slowly to approximately the 1/4 open position.

IMPORTANT: If opened too rapidly or too far, resin may be lost. In this position, you should hear air escaping slowly from the drain line.

- c. When all of the air has been purged from the tank (water begins to flow steadily from the drain), open the water supply valve all the way.
 - d. Allow water to run to drain until clear.
 - e. Turn off water supply and let the unit stand for about five minutes. This will allow all trapped air to escape from the tank.
4. Add water to brine tank (initial fill).

With a bucket or hose, add approximately 4 gallons (15 liters) of water to brine tank. If the tank has a salt platform above the bottom of the tank, add water until the level is approximately 1 inch (25 mm) above the platform.

5. Put into operation.
 - a. Open water supply valve slowly to full open position.
 - b. Carefully advance indicator knob **COUNTERCLOCKWISE** to center of **FAST RINSE/REFILL** position and hold there until air check (Figure 10) fills with water and water starts to flow through brine line into brine tank. Do not run for more than two minutes.
 - c. Advance indicator knob **COUNTERCLOCKWISE** until arrow points to the center of the **BRINE/ SLOW RINSE** position.
 - d. With the conditioner in this position, check to see if water is being drawn from the brine tank. The water level in the brine tank will recede very slowly. Observe for at least three minutes. If the water level does not recede or goes up, or if air enters the transparent air check chamber and the ball falls and seats, reference **Troubleshooting** section.
 - e. Advance indicator knob **COUNTERCLOCKWISE** to **CONDITIONED WATER**.
 - f. Run water from a nearby faucet until the water is clear and soft.

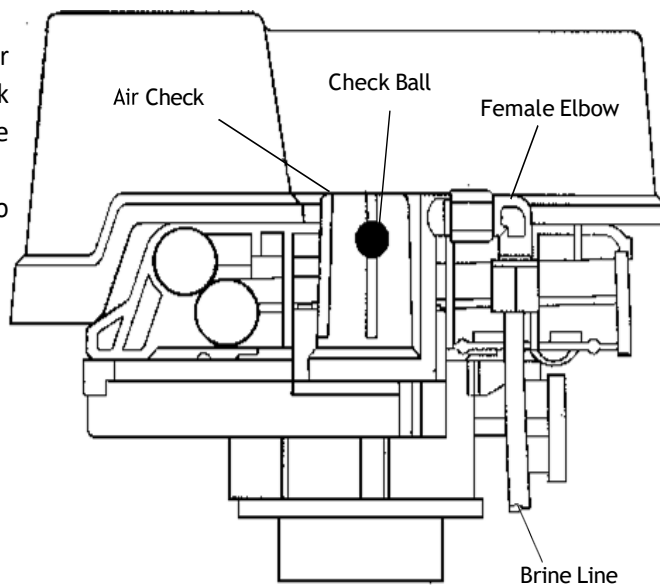

460i Control

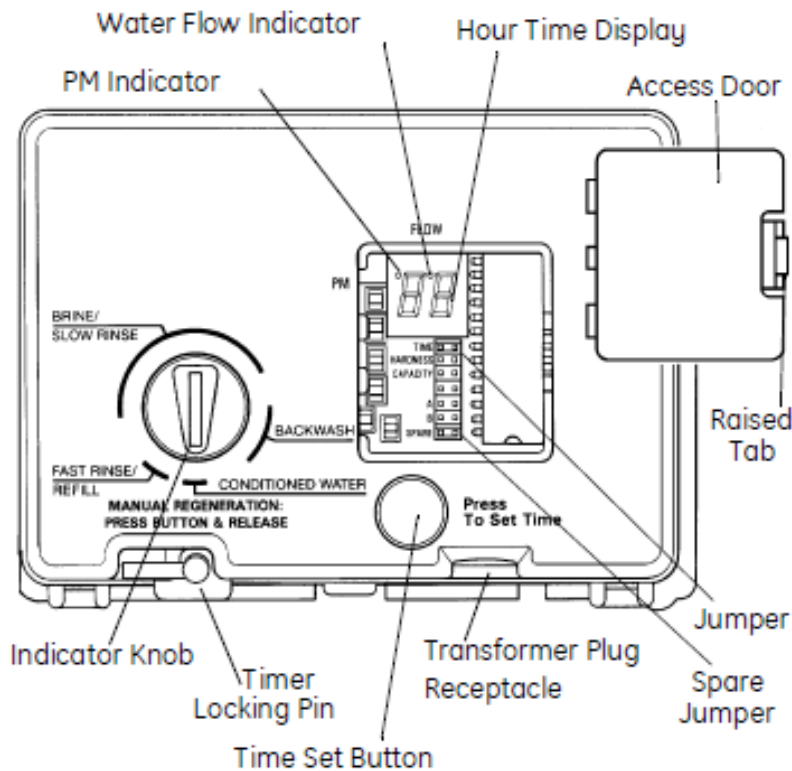

Programming

Plug the wall-mount transformer into a functioning electrical outlet that is not controlled by a switch. Plug the transformer into the transformer plug receptacle on the control.

Open the access door by pushing the raised tab on the door toward the left while pulling the tab out (Figure 12).

Time of Day Setting

With the jumper on the set of pins next to the word **TIME** (Figure 13), set the time of day to the closest hour by pressing the black **TIME SET** button. PM hours are indicated by a light next to the letters **PM** on the display window.

Note: The use of a small needle-nose pliers will aid in moving the jumper.

Note: The unit is factory set to regenerate at 2:00 a.m. If you prefer to have the unit regenerate at an earlier or later time, simply set the current time of day accordingly (e.g., to have the unit regenerate at 4:00 a.m.—two hours later—set the clock two hours earlier than the actual time of day).

Note: The Timer Locking Pin should always be horizontal (Figure 12) during operation.

Hardness Setting

Move the jumper to the set of pins next to the word **HARDNESS** (Figure 14). Press the black TIME SET button until the hardness of the incoming water supply is displayed. The hardness range is from 1 to 99 grains per gallon.

To change water hardness stated in parts per million (PPM) to grains per gallon (GPG) use this formula:

$$\frac{\text{Parts per Million}}{17.1} = \text{Grains per Gallon}$$

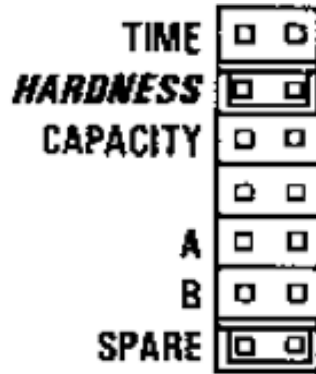
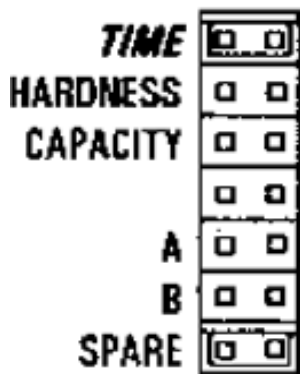

Capacity Setting

Move the jumper to the set of pins next to the word **CAPACITY** (Figure 15). Press the black TIME SET button until the correct capacity value is displayed. The capacity range is 1 to 99 kilograins. Refer to the Suggested Salt Dial Settings table.

Return the jumper to the top set of pins next to the word **TIME** and replace the access door. **The jumper must NOT be left on any pins other than the top pair next to the word TIME.** Otherwise, the unit may show a blank display.

Note: A spare jumper is located on the bottom set of pins.

In the event that the hardness or capacity setting must be changed, simply follow the appropriate steps described above.

Calendar Override Setting

1. Disconnect power.
2. Place jumper on Pin A and reconnect power.
3. Move jumper to Pin B. A zero will appear, indicating zero days of calendar override. All 460i controllers are preprogrammed in this manner at the manufacturer.
4. Depress the black TIME SET button. The numbers will roll from "0" to "15." Release the switch at the desired number of days for the calendar override. For example, releasing the switch at "10" would program a 10-day calendar override.
5. Disconnect power.
6. Place jumper back on TIME and reconnect power.
7. The calendar override program is maintained during power outages by the NOVRAM circuitry.
8. To remove the calendar override, follow the same steps above and program back to "0."

Common Features

When using the 255 valve with the 440i or 460i controls, there are several features and procedures that are unique to the 400 series controls. They are as follows:

Salt Dial Adjustment

These models may be adjusted to produce maximum to minimum conditioning capacities by setting the salt dial, which controls the amount of salt used per regeneration. When desired, the minimum setting may be used on installations if the frequency of regeneration is increased to compensate for lower regenerated conditioning capacity. The installing dealer will set the unit for proper salt usage.

Further adjustments are needed only if the hardness of the water supply changes or if water use changes dramatically. Capacity will need to be adjusted accordingly.

To adjust salt dosage, insert a small screwdriver into the white indicator knob and move pointer to proper salt setting.

Note: To convert the salt settings from English to metric, divide by 2.2 (e.g., 12 pounds \div 2.2 = 5.5 kg of salt).

Table 1 – Suggested Salt Dial Settings (Pounds of Salt) For Various Size Softeners

Capacity Setting (Kilograins)	0.5 Ft ³	0.75 Ft ³	1.0 Ft ³	1.25 Ft ³	1.5 Ft ³	1.75 Ft ³	2.0 Ft ³
12	4.5	—	—	—	—	—	—
16	9.0	5.5	—	—	—	—	—
20	—	8.5	6.0	—	—	—	—
24	—	14.0	8.5	7.0	—	—	—
30	—	—	15.0	11.0	9.0	—	—
32	—	—	18.5	12.5	10.0	9.0	—
35	—	—	—	16.0	12.0	10.0	9.0
40	—	—	—	11.5*	17.0	14.0	12.0
48	—	—	—	—	14.0*	10.5*	17.0
60	—	—	—	—	—	—	15.0*

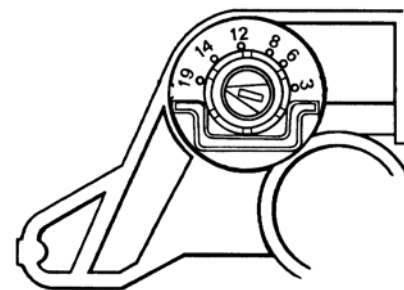

*This setting requires the use of “XS” (extra salt) cam and doubles the amount of the setting.

The amount of salt placed in the brine tank has nothing to do with the amount of salt used during the regeneration cycle. Water will dissolve and absorb salt only until it becomes saturated. A given amount of brine (salt-saturated water) contains a specific amount of salt. The salt dial controls the amount of brine used during the regeneration cycle (e.g., when set at 15 pounds (6.8 kg) the amount of brine the conditioner will use for each regeneration will contain 15 pounds (6.8 kg) of salt, etc.)

Never let the amount of salt in the brine tank be lower than the normal liquid level. Do not overload the brine tank with salt.

Guest Cycle (Manual Regeneration)

When abnormally high water usage exhausts your water conditioner’s capacity ahead of schedule, an extra regeneration can be achieved. Depress the indicator knob on the 440i (Figure 11) with a wide-blade screwdriver and turn **COUNTERCLOCKWISE** to **START** to initiate a regeneration. For the 460i, simply depress the indicator knob (Figure 12). It will take a few minutes for regeneration to start. A normal regeneration will take approximately two hours.

Preventive Maintenance

Inspect and clean brine tank and screen filter on end of brine pickup tube once a year or when sediment appears in the bottom of the brine tank.

Clean injector screen and injector **once a year**:

1. Unplug the wall-mount transformer.
2. Shut off water supply or put bypass valve(s) into bypass position.
3. Relieve system pressure by opening valve No. 5 (at rear) with a screwdriver.
4. Using a screwdriver, remove injector screen and injector cap (Figure 16).
5. Clean screen using a fine brush. Flush until clean.
6. Using a needle-nose pliers, pull injector straight out.
7. Flush water into the injector screen recess of the valve body to flush debris out through the injector recess.
8. Clean and flush the injector.
9. Lubricate the O-rings on the injector, injector cap and injector screen with silicone lubricant.
10. Reinstall the injector, injector cap and injector screen. See **IMPORTANT** note.
11. Plug the wall-mount transformer into outlet; reset time of day.
12. Slowly open water supply valve or return bypass valve(s) to the “not in bypass” position.

IMPORTANT: Do not overtighten the plastic cap. Seat the cap lightly into position. Overtightening may cause breakage of the plastic cap that may not be immediately evident.

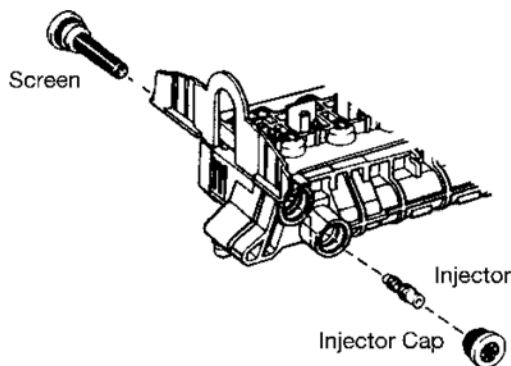

Replacement Parts for Autotrol Brand 255 Control

Valve Body

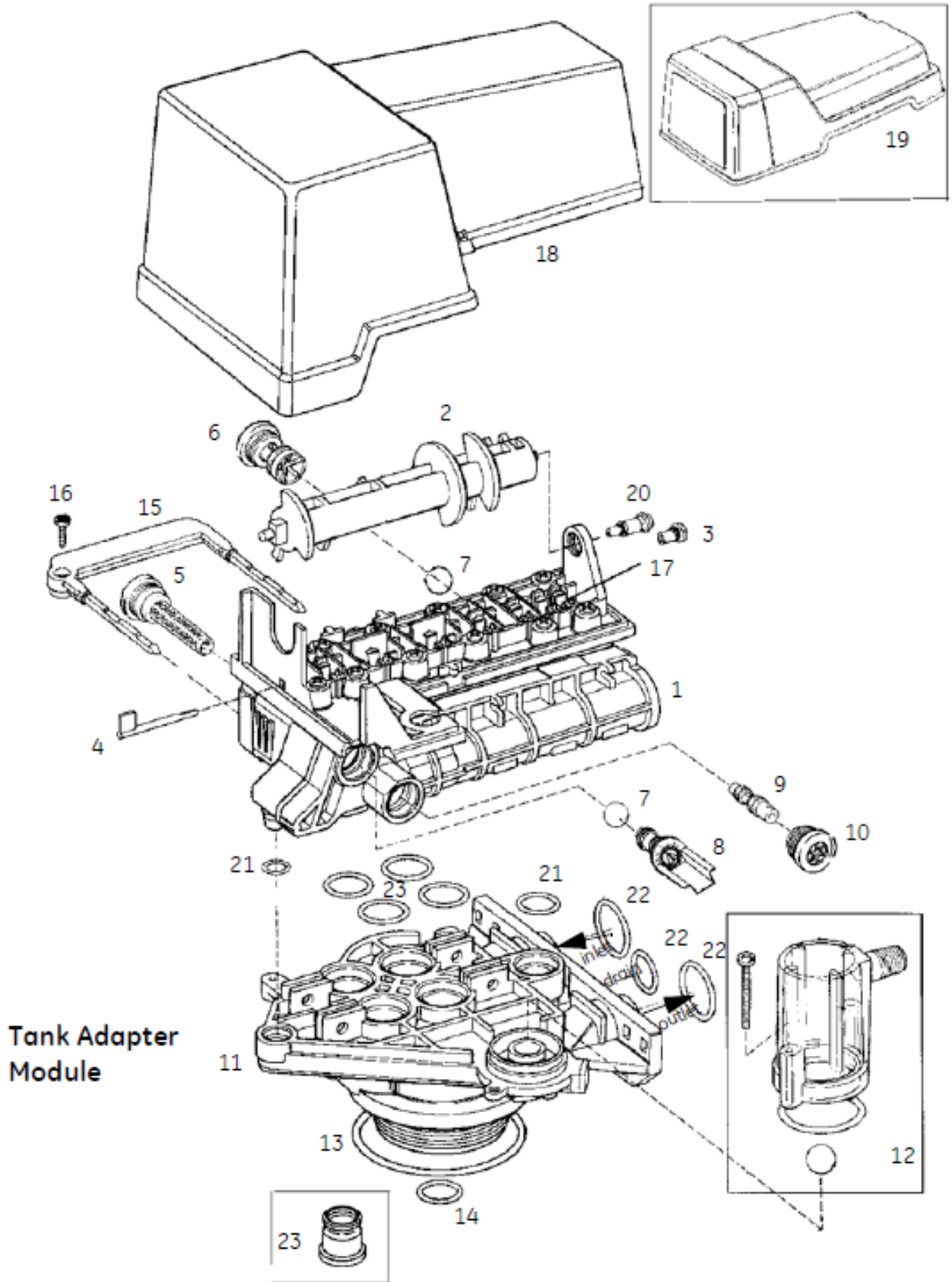

255 Valve & Tank Adapter Module

Code	Part No.	Description	Qty.
1	1000232	Valve Assembly, w/o Flow Controls	1
2		Camshaft:	1
	1031950	Standard, One-Piece	
	1033024	Standard, Segmented	
	1033025	Extra Salt, Segmented	
	1033026	Long Rinse, Segmented	
	1032969	Water Saver, Segmented	
3	1030501	Camshaft Bearing	1
4	1031391	Timer Locking Pin	1
5	1000226	Screen/Cap Assembly w/O-Ring	1
6		Drain Control Assembly w/O-Rings:	1
	1000209	No. 7 (1.2 gpm; 4.5 Lpm)	
	1000210	No. 8 (1.6 gpm; 6.1 Lpm)	
	1000211	No. 9 (2.0 gpm; 7.6 Lpm)	
	1000212	No. 10 (2.5 gpm; 9.5 Lpm)	
	1000213	No. 12 (3.5 gpm; 13.2 Lpm)	
	1000214	No. 13 (4.1 gpm; 15.5 Lpm)**	
	1000215	No. 14 (4.8 gpm; 18.2 Lpm)**	
7	1030502	Ball, Flow control	2
8		Brine Refill Control:	1
	1034261	1 to 10 lbs Salt	
	1034263	3 to 19 lbs Salt	
9		Injector Assembly with O-Rings:	1
	1032970	"A" Injector - White	
	1032971	"B" Injector - Blue	
	1032972	"C" Injector - Red	
10	1000269	Injector Cap with O-Ring	1
12	1032416	Air Check Kit	1
13	1010429	O-Ring BN	1
14	1010428	O-Ring EP	1
15		Locking Bar:	1
	1031402	English Language	
	1031403	French Language	
	1031404	German Language	
	1031405	Italian Language	
	1031406	Japanese Language	
	1031407	Spanish Language	
16	1006093	Screw, No. 8 x 9/16 inch	1
17	1001580	Spring, Valve Discs	9
18	1032565	Valve Cover, Standard, Black	1
19	1000062	i-Lid Cover	1
20	1000297	Extended Connector (For use with i-Lid Cover)	1
21	1001404	O-Ring Group: Tank Adapter, 1010117 (1), 1010407 (1), 1010410 (4)	
22	1040459	O-Ring Group: Piping Boss 1010431 (1), 1010411 (2)	
23	1041010	13/16 Rubber Insert (Optional)	
		Valve Discs:	
*	1000250	Standard	

* Not Shown | **Flow control does not use Flow Control Ball (1030502).

Replacement Parts

440i

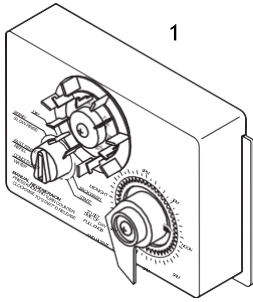

460i

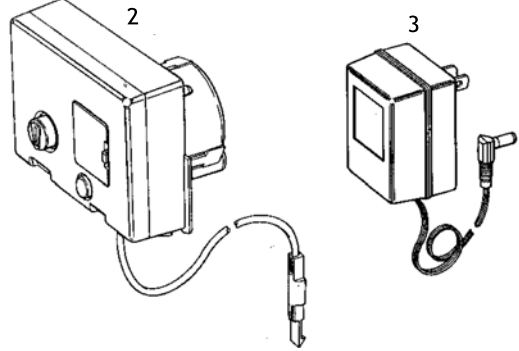

Meter Adapter

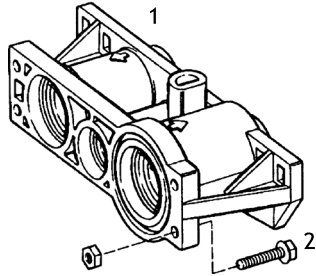

256 Bypass Valve

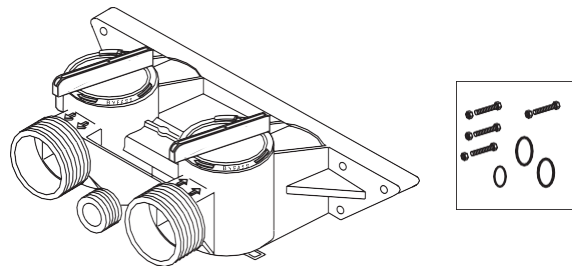

Piping Boss

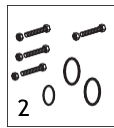
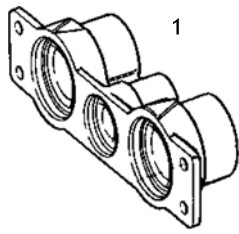

Note: Do not use pipe joint compound when threading pipe into the Noryl piping boss. Use only Teflon* pipe tape. Do not overtighten pipe into Noryl piping boss.

255 Series Accessories

Code	Part No.	Description	Qty.
1		440i Assembly	1
2		460i Assembly	1
3		Transformer	1
	1000810	Japanese	
	1000811	North American	
	1000812	Australian	
	1000813	British	
	1000814	European	
*	1030234	Transformer Extension Cord 15 foot (4.5 m)	1
Piping Boss			
1		Piping Boss Kit (includes Hardware): 3/4-	1
	1040277	inch NPT, Brass 3/8-inch NPT Drain	
	1040278	1-inch NPT, Brass 1/2-inch NPT Drain	
	1040281	3/4-inch BSPT, Brass 3/8-inch BSPT Drain	
	1040282	1-inch BSPT, Brass 1/2-inch BSPT Drain	
	1040279	3/4-inch NPT, Noryl 1/2-inch NPT Drain	
	1040280	1-inch NPT, Noryl 1/2-inch NPT Drain	
	1040283	3/4-inch BSPT, Noryl 1/2-inch BSPT Drain	
	1040284	1-inch BSPT, Noryl 1/2-inch BSPT Drain	
2	1040339	Piping Boss installation Kit	1
Meter Adapter			
1	1032350	Kit, Meter Adapter	1
2	1032351	Meter Install Kit	1
Bypass Valve			
1	1040769	Bypass Body Assembly with Install Kit	1
2	1040524	Bypass Installation Kit	1
Tube Adapter Kits			
*	1001606	3/4-inch Copper Tube Adapter Kit	1
*	1001670	1-inch Copper Tube Adapter Kit	1
*	1041210	1-1/4-inch Copper Tube Adapter Kit	1
*	1040547	90 degree Elbow Adapter Kit	1
*	1001608	22-mm Copper Tube Adapter Kit	1
*	1001613	3/4-inch CPVC Tube Adapter Kit	1
*	1001614	1-inch CPVC Tube Adapter Kit	1
*	1001615	25-mm CPVC Tube Adapter Kit	1
*	1001769	3/4-inch NPT Plastic Pipe Adapter Kit	1
*	1001603	1-inch NPT Plastic Pipe Adapter Kit	1
*	1001604	3/4-inch BSPT Plastic Pipe Adapter Kit	1
*	1001605	1-inch BSPT Plastic Pipe Adapter Kit	1
*	1001611	3/4-inch BSPT Brass Pipe Adapter Kit	1
*	1001610	1-inch NPT Brass Pipe Adapter Kit	1
*	1001612	1-inch BSPT Brass Pipe Adapter Kit	1

Troubleshooting

The technology upon which the Series 255 control is based is well-established and proven in service over many years. However, should a problem or question arise regarding the operation of the system, the control can be very easily serviced. The control module can be quickly replaced or adjustments can be made at the installation. We recommend that you contact your local professional water treatment dealer for most concerns. For parts mentioned, refer to exploded views in the **Replacement Parts** section of this manual.

IMPORTANT: Service procedures that require the water pressure to be removed from the system are marked with a ! after the possible cause. Refer to Preventative Maintenance section for instructions.

Valve Troubleshooting

Problem	Possible Cause	Solution
1. Brine tank overflow.	<ul style="list-style-type: none"> a. Uncontrolled brine refill flow rate. b. Air leak in brine line to air check. c. Drain control clogged with resin or other debris. 	<ul style="list-style-type: none"> a. Remove brine control to clean ball and seat. b. Check all connections in brine line for leaks. Refer to instructions. c. Clean drain control.
2. Flowing or dripping water at drain or brine line after regeneration.	<ul style="list-style-type: none"> a. Valve stem return spring weak. 	<ul style="list-style-type: none"> a. Replace spring. (Contact dealer.)
3. Hard water leakage after regeneration.	<ul style="list-style-type: none"> a. Improper regeneration. b. Leaking of external bypass valve. c. O-ring around riser pipe damaged. 	<ul style="list-style-type: none"> a. Repeat regeneration after making certain correct salt dosage was set. b. Replace bypass valve. (Contact dealer.) c. Replace O-ring. (Contact dealer.)
4. Control will not draw brine.	<ul style="list-style-type: none"> a. Low water pressure. b. Restricted drain line. c. Injector plugged ! d. Injector defective ! e. Valve disc 2 and/or 3 not closed. f. Air check valve prematurely closed. 	<ul style="list-style-type: none"> a. Make correct setting according to instructions. b. Remove restriction. c. Clean injector and screen. d. Replace injector and cap. (Contact dealer.) e. Remove foreign matter from disc and check disc for closing by pushing in on stem. Replace if needed. (Contact dealer.) f. Put control momentarily into brine refill. Replace or repair air check if needed. (Contact dealer.)

260i Troubleshooting

Problem	Possible Cause	Solution
1. No water flow display when water is flowing.	<ul style="list-style-type: none"> a. Bypass valve in bypass. b. Meter probe disconnected or not fully connected to meter housing. c. Restricted meter turbine rotation due to foreign material in meter ! d. Defective meter probe. 	<ul style="list-style-type: none"> a. Shift bypass valve to not-in- bypass position. b. Fully insert probe into meter housing. c. Remove meter housing, free up turbine and flush with clean water. Turbine should spin freely. If not, replace meter. (Contact dealer.) d. Replace meter cable (Contact dealer.)
2. Continuous regeneration. Camshaft does not stop at the end of regeneration.	<ul style="list-style-type: none"> a. Misaligned optical sensor. 	<ul style="list-style-type: none"> a. Replace optical sensor. (Contact dealer.)
3. Run out of soft water between regenerations.	<ul style="list-style-type: none"> a. Improper regeneration. b. Incorrect salt setting. c. Incorrect hardness or capacity settings. d. Water hardness has increased. e. Restricted meter turbine rotation due to foreign material in meter ! 	<ul style="list-style-type: none"> a. Repeat regeneration, making certain that correct salt dosage is used. b. Set salt control to proper level. See salt setting chart. c. Set to correct values. See Programming section. d. Set hardness to new value. See Programming section. e. Remove meter housing, free up turbine and flush with clean water. Turbine should spin freely; if not, replace meter. (Contact dealer.)

Valve Specifications

Working Pressure20-120 psi (1.38 - 8.27 bar)

Standard 12 Volt Transformer Input Electrical Rating 115V 60 Hz

Optional 12 Volt Transformer Input Electrical Rating..... 115V 50 Hz, 230V 50 Hz,
230V 60 Hz, 100V 60 Hz, 100V 50 Hz

Operating Ambient Temperature 34 °F to 120 °F (1 °C to 49 °C)

Operating Water Temperature..... 34 °F to 100 °F (1 °C to 38 °C)

Water Treatment System Warranty

This quality FRAKCO water softener is designed and built to provide many years of satisfactory performance under normal use. FRAKCO, INC. pledges to the original owner that for sixty months, all non-wearable items of the above-described water treatment system proven to be defective due to workmanship and/or materials will be replaced or repaired. FRAKCO also pledges that the fiberglass media tank is covered under this warranty for ten years if owned by the original purchaser. Our pledge does not apply if the damage is caused by defective installation; water pressure in excess of eighty pounds per square inch; water temperature in excess of 110° F.; misuse; unauthorized alterations; freezing; accident; fire; neglect; or damage caused by shipping.

To obtain service under this warranty, notify FRAKCO, INC in writing of any defects in workmanship within thirty days of the appearance of such defects. Such written notice must include the date of purchase, the part number, and a description of the defect. Upon receiving such notice and determining that the defect is covered by this warranty, FRAKCO, INC. will replace or repair the defective item. Replacement of a defective item will be at FRAKCO'S factory in Luverne, MN, and the purchaser must ship the defective item at its own expense to FRAKCO'S factory. Replacement items will be shipped by FRAKCO F.O.B. Luverne, Minnesota, with a shipping carton furnished. In the event certain models or colors of the replacement item are out of stock, FRAKCO, INC. may, after notifying the purchaser, furnish another model or color of the replacement item. The factory will not pay for service charges and will not perform any repair or service functions other than at its home office.

Please follow the enclosed instructions and local codes in installing your water treatment system. Failure to do so will void this warranty. Nothing in the warranty may be construed as involving the factory in the relationship between Dealer and Owner.

This warranty gives the purchaser specific legal rights. The purchase may also have implied warranty rights. In the event of a problem with warranty service or performance, the purchaser may be able to go to a Small Claims Court, a State Court, or a Federal District Court. This warranty complies with the 1975 Federal Warranty Law.

Model No. _____ Serial No. _____

Date Installed _____ Dealer _____

Address _____

*MANUFACTURED BY: FRAKCO, INC.
500 N BLUE MOUND AVE
LUVERNE, MINNESOTA
56156
WWW.FRAKCO.COM*