



Plus
AQUA MAGIC



Owner and Operational Manual

Model: _____

Serial Number: _____

Install Date: _____

Installed By: _____

Service Phone: _____

Sold By: _____



Please read this manual carefully before proceeding with installation. Your failure to follow any of these instructions or operating parameters may lead to personal injury or damage to the equipment and/or personal property. Do not use this water treatment system with water that is microbiologically unsafe or of unknown quality, without adequate disinfection before or after the system. This water treatment system contains replaceable treatment components critical for effective performance. It is the user's responsibility to periodically test the product water to verify the system is performing satisfactorily. Failure to properly maintain this water treatment system may cause a health risk.

Save this manual for future reference.



Aqua Magic 3900
04.15.2024 SB

Table of Contents

- Installation 3
- Start-Up Instructions 3
- 3200 Timer Setting Procedure 4
- 3210 & 3220 Timer Setting Procedure 4
- 3200, 3210, 3220, 3230 Regeneration Cycle Setting Procedure..... 5
 - Timer Setting Procedure 5
- 3200 Time Clock Timer Assembly 6
 - Continued..... 7
- 3210 Meter Delayed Timer Assembly 8
 - Continued..... 9
- 3220 Meter Immediate Timer Assembly 10
- 3230 Remote Start Timer Assembly 12
 - Continued..... 13
- Control Drive Assembly 14
- Adapter Control Drive Lower Powerhead 16
- Control Valve..... 18
- 1800 Series Brine System And Drain Line Flow Control Assembly 20
- 1800 Series Brine System And Drain Line Flow Control Assembly *Continued* 21
- 1800 Series Brine System And Drain Line Flow Control Assembly *Continued* 22
- 1800 Series Brine System And Drain Line Flow Control Assembly *Continued* 23
- 3- Inch Meter Assembly 24
- Service Valve Operator Assembly 25
- Troubleshooting 26
- General Service Hints For Meter Control 27
- Water Conditioner Flow Diagrams..... 27
 - 1 Service Position 27
 - 2 Backwash Position..... 27
 - Continued..... 28
 - 3 Brine Position..... 28
 - 5 Rapid Rinse Position..... 28
 - 4 Slow Rinse Position..... 28
 - 6 Brine Tank Refill Position 28
- Dimensional Drawing 3900 Top Mount 29
- Dimensional Drawing 3900 Side Mount..... 30
- Typical Installations 31
 - System #4 - Typical Single Tank Installation With Optional Meter 31
 - System #6 Interlock - Typical Twin Tank Installation With Optional Meter Interlock And Nhwb 31
- Valve Wiring 32
 - System #4..... 32
 - System #5..... 33
 - System #6..... 34
 - System #7..... 35
- Water Treatment System Warranty 37**

INSTALLATION

Water Pressure

A minimum of 20 pounds (1.4 bar) of water pressure is required for regeneration valve to operate effectively.

Electrical Facilities

An uninterrupted alternating current (A/C) supply is required.

NOTE: Other voltages are available. Please make sure your voltage supply is compatible with your unit before installation.

Existing Plumbing

Condition of existing plumbing should be free from lime and iron buildup. Piping that is built up heavily with lime and/or iron should be replaced. If piping is clogged with iron, a separate iron filter unit should be installed ahead of the water softener.

Location Of Softener And Drain

The softener should be located close to a drain to prevent air breaks and back flow.

By-Pass Valves

Always provide for the installation of a by-pass valve if unit is not equipped with one.

CAUTION Water pressure is not to exceed 125 psi (8.6 bar), water temperature is not to exceed 110°F (43°C), and the unit cannot be subjected to freezing conditions.

Installation Instructions

1. Place the softener tank where you want to install the unit making sure the unit is level and on a firm base.
2. During cold weather, the installer should warm the valve to room temperature before operating.
3. All plumbing should be done in accordance with local plumbing codes. The pipe size for residential drain line should be a minimum of 1/2 inch (13 mm). Backwash flow rates in excess of 7 gpm (26.5 Lpm) or length in excess of 20 feet (6 m) require 3/4 -inch (19 mm) drain line. Commercial drain lines should be the same size as the drain line flow control.
4. Refer to the dimensional drawing for cutting height of the distributor tube. If there is no dimensional drawing, cut the distributor tube flush with the top of the tank.
5. Lubricate the distributor o-ring seal and tank o-ring seal. Place the main control valve on tank.

NOTE: Only use silicone lubricant.

6. Solder joints near the drain must be done prior to connecting the Drain Line Flow Control fitting (DLFC). Leave at least 6 inches (15 cm) between the DLFC and solder joints when soldering pipes that are connected on the DLFC. Failure to do this could cause interior damage to the DLFC.
7. Plumber tape is the only sealant to be used on the drain fitting. The drain from twin tank units may be run through a common line.
8. Make sure that the floor is clean beneath the salt storage tank and that it is level.
9. Place approximately 1 inch (25 mm) of water above the grid plate. If a grid is not utilized, fill to the top of the air check (Figure 1) in the salt tank. Do not add salt to the brine tank at this time.

10. On units with a by-pass, place in by-pass position. Turn on the main water supply. Open a cold soft water tap nearby and let run a few minutes or until the system is free from foreign material (usually solder) that may have resulted from the installation. Once clean, close the water tap.

11. Slowly place the by-pass in service position and let water flow into the mineral tank. When water flow stops, slowly open a cold water tap nearby and let run until the air is purged from the unit.

12. Plug unit into an electrical outlet.

NOTE: All electrical connections must be connected according to local codes. Be certain the outlet is uninterrupted.

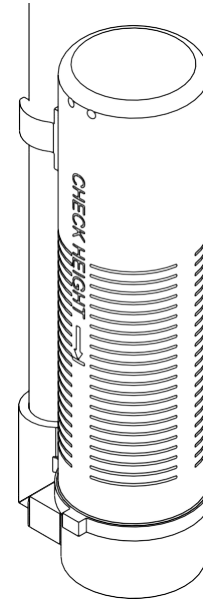

60002 Rev E

Figure 1 Residential Air Check Valve

START-UP INSTRUCTIONS

The water softener should be installed with the inlet, outlet, and drain connections made in accordance with the manufacturer's recommendations, and to meet applicable plumbing codes.

1. Turn the manual regeneration knob slowly in a clockwise direction until the program micro switch lifts on top of the first set of pins. Allow the drive motor to move the piston to the first regeneration step and stop. Each time the program switch position changes, the valve will advance to the next regeneration step. Always allow the motor to stop before moving to the next set of pins or spaces.

NOTE: For electronic valves, please refer to the manual regeneration part of the timer operation section. If the valve came with a separate electronic timer service manual, refer to the timer operation section of the electronic timer service manual.

2. Position the valve to backwash. Ensure the drain line flow remains steady for 10 minutes or until the water runs clear (see above).
3. Position the valve to the brine / slow rinse position. Ensure the unit is drawing water from the brine tank (this step may need to be repeated).
4. Position the valve to the rapid rinse position. Check the drain line flow, and run for 5 minutes or until the water runs clear.

STARTUP INSTRUCTIONS *CONTINUED*

- Position the valve to the start of the brine tank fill cycle. Ensure water goes into the brine tank at the desired rate. The brine valve drive cam will hold the valve in this position to fill the brine tank for the first regeneration.
- Replace control box cover.
- Put salt in the brine tank.

NOTE: Do not use granulated or rock salt.

3200 TIMER SETTING PROCEDURE

How To Set Days On Which Water Conditioner Is To Regenerate (Figure 2)

Rotate the skipper wheel until the number "1" is at the red pointer. Set the days that regeneration is to occur by sliding tabs on the skipper wheel outward to expose trip fingers. Each tab is one day. Finger at red pointer is tonight. Moving clockwise from the red pointer, extend or retract fingers to obtain the desired regeneration schedule.

How To Set The Time Of Day

- Press and hold the red button in to disengage the drive gear.
- Turn the large gear until the actual time of day is at the time of day pointer.
- Release the red button to again engage the drive gear.

How To Manually Regenerate Your Water Conditioner At Any Time

- Turn the manual regeneration knob clockwise.
- This slight movement of the manual regeneration knob engages the program wheel and starts the regeneration program.
- The black center knob will make one revolution in the following approximately three hours and stop in the position shown in the drawing.
- Even though it takes three hours for this center knob to complete one revolution, the regeneration cycle of your unit might be set for only one half of this time.
- In any event, conditioned water may be drawn after rinse water stops flowing from the water conditioner drain line.

How to Adjust Regeneration Time

- Disconnect the power source.
- Locate the three screws behind the manual regeneration knob by pushing the red button in and rotating the 24 hour dial until each screw appears in the cut out portion of the manual regeneration knob.
- Loosen each screw slightly to release the pressure on the time plate from the 24-hour gear.
- Locate the regeneration time pointer on the inside of the 24-hour dial in the cut out.
- Turn the time plate so the desired regeneration time aligns next to the raised arrow.
- Push the red button in and rotate the 24-hour dial. Tighten each of the three screws.
- Push the red button and locate the pointer one more time to ensure the desired regeneration time is correct.
- Reset the time of day and restore power to the unit.

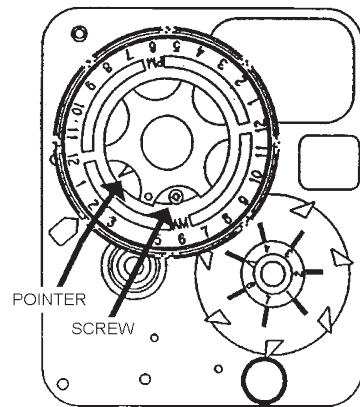
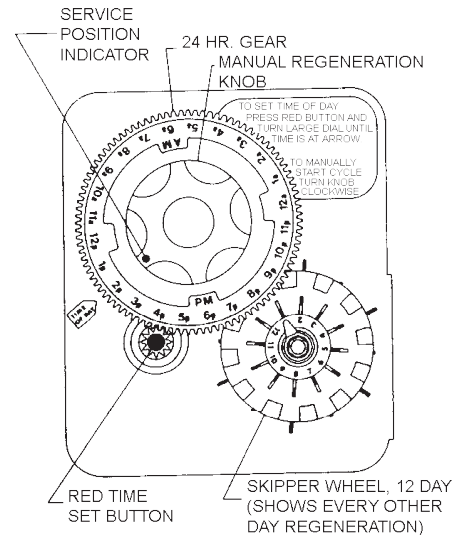

3200 ADJUSTABLE REGENERATION TIMER

IMPORTANT!
SALT LEVEL MUST ALWAYS BE ABOVE
WATER LEVEL IN BRINE TANK

61502-3200 Rev A

Figure 2

3210 & 3220 TIMER SETTING PROCEDURE

Typical Programming Procedure

Calculate the gallon capacity of the system, subtract the necessary reserve requirement and set the gallons available opposite the small white dot on the program wheel gear (Figure 3).

NOTE: Drawing shows 8,750 gallon setting. The capacity (gallons) arrow (15) shows zero gallons remaining. The unit will regenerate tonight at the set regeneration time.

How To Set The Time Of Day

- Press and hold the red button in to disengage the drive gear.
- Turn the large gear until the actual time of day is opposite the time of day pointer.
- Release the red button to again engage the drive gear.

How To Manually Regenerate Your Water Conditioner At Any Time

- Turn the manual regeneration knob clockwise.

3210 & 3220 TIMER SETTING

PROCEDURE CONTINUED

- This slight movement of the manual regeneration knob engages the program wheel and starts the regeneration program.
- The black center knob will make one revolution in the following approximately three hours and stop in the position shown in the drawing.
- Even though it takes three hours for this center knob to complete one revolution, the regeneration cycle of your unit might be set for only one half of this time.
- In any event, conditioned water may be drawn after rinse water stops flowing from the water conditioner drain line.

Immediate Regeneration Timers

These timers do not have a 24-hour gear. Setting the gallons on the program wheel and manual regeneration procedure are the same as previous instructions. The timer will regenerate as soon as the capacity gallons reaches zero.

NOTE: The program wheel to the left may be different than the program wheel on the product.

NOTE: To set meter capacity rotate manual knob one - 360° revolution to set gallonage.

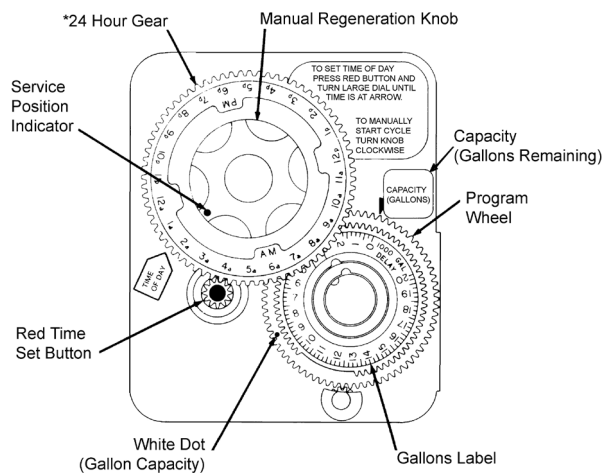

*Immediate regeneration timers do not have a 24-hour gear. No time of day can be set.

61502-3200 Rev A

Figure 3

3200, 3210, 3220, 3230 REGENERATION CYCLE SETTING PROCEDURE

How To Set The Regeneration Cycle Program

The regeneration cycle program on your water conditioner has been factory preset, however, portions of the cycle or program may be lengthened or shortened in time to suit local conditions.

3200 Series Timers (Figure 4)

- To expose cycle program wheel, grasp timer in upper left-hand corner and pull, releasing snap retainer and swinging timer to the right.
- To change the regeneration cycle program, the program wheel must be removed. Grasp program wheel and squeeze protruding lugs toward center, lift program wheel off timer. Switch arms may require movement to facilitate removal.

- Return timer to closed position engaging snap retainer in back plate. Make certain all electrical wires locate above snap retainer post.

Timer Setting Procedure

How To Change The Length Of The Backwash Time

The program wheel as shown in the drawing is in the service position. As you look at the numbered side of the program wheel, the group of pins starting at zero determines the length of time your unit will backwash.

For example, if there are six pins in this section, the time of backwash will be 12 min. (2 min. per pin). To change the length of backwash time, add or remove pins as required. The number of pins times two equals the backwash time in minutes.

How To Change The Length Of Brine And Rinse Time

- The group of holes between the last pin in the backwash section and the second group of pins determines the length of time that your unit will brine and rinse (2 min. per hole).
- To change the length of brine and rinse time, move the rapid rinse group of pins to give more or fewer holes in the brine and rinse section. Number of holes times two equals brine and rinse time in minutes.

How To Change The Length Of Rapid Rinse

- The second group of pins on the program wheel determines the length of time that your water conditioner will rapid rinse (2 min. per pin).
- To change the length of rapid rinse time, add or remove pins at the higher numbered end of this section as required. The number of pins times two equals the rapid rinse time in minutes.

How To Change The Length Of Brine Tank Refill Time

- The second group of holes in the program wheel determines the length of time that your water conditioner will refill the brine tank (2 min. per hole).
- To change the length of refill time, move the two pins at the end of the second group of holes as required.
- The regeneration cycle is complete when the outer microswitch is tripped by the two pin set at end of the brine tank refill section.
- The program wheel, however, will continue to rotate until the inner micro switch drops into the notch on the program wheel.

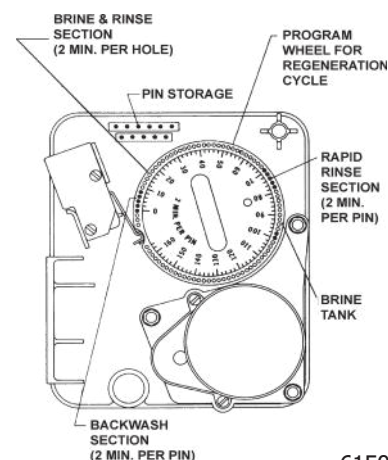

61502-3210 Rev A

Figure 4

3200 TIME CLOCK TIMER ASSEMBLY

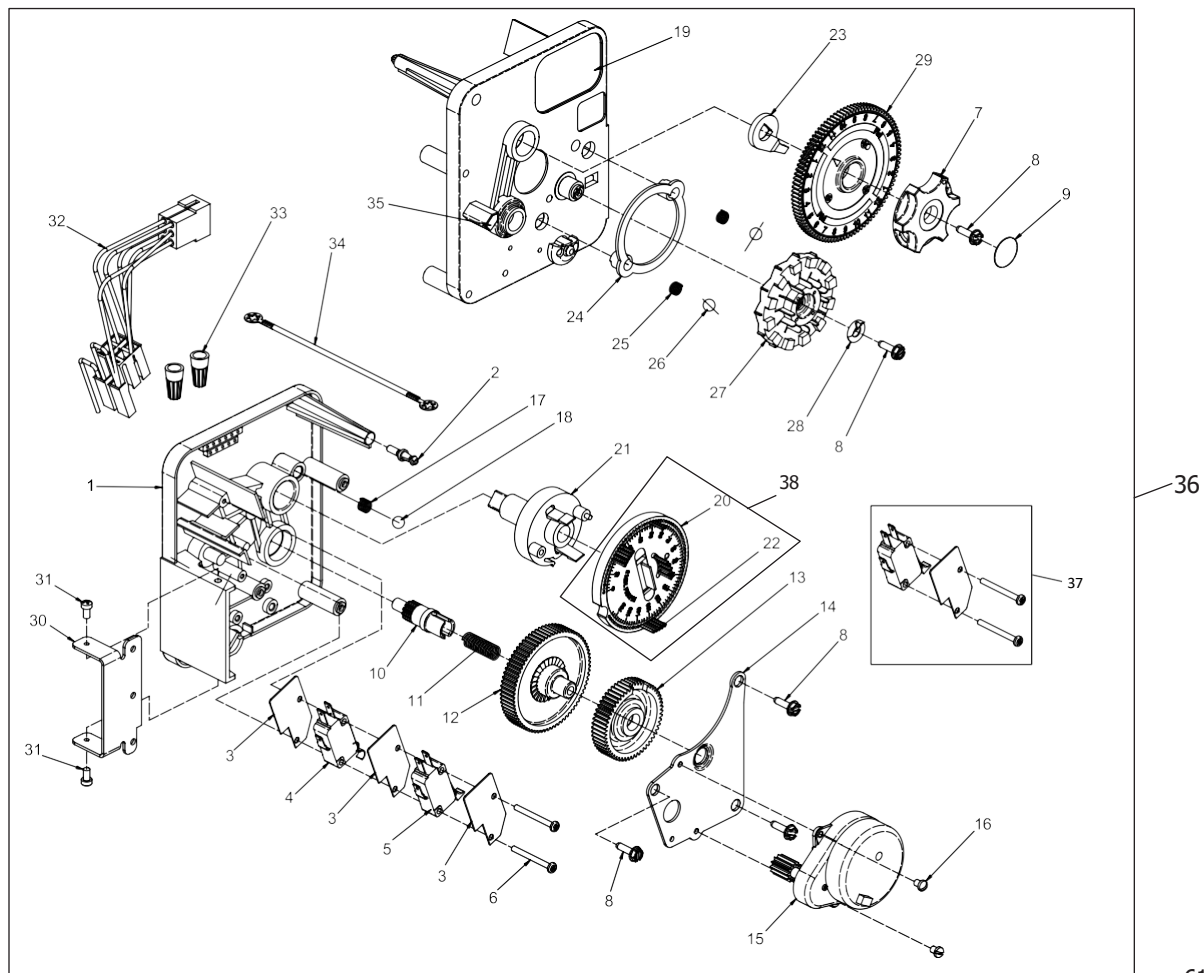

615023200 Rev A

3200 TIME CLOCK TIMER ASSEMBLY

CONTINUED

Item No.	QTY	Part No.	Description	Item No.	QTY	Part No.	Description
1	1	13870	Housing, Timer, 3200	25	2	13311	Spring, Detent, Timer
2	1	14265	Clip, Sping	26	2	13300	Ball, 1/4-inch, SS
3	3	14087	Insulator	27	1	14381	Skipper Wheel Assy, 12 Day
4	1	10896	Switch, Micro			14860	Skipper Wheel Assy, 7 Day
5	1	15320	Switch, Micro, Timer	28	1	13014	Pointer, Regeneration
6	2	11413	Screw, Pan Hd Mach, 4-40 x 1-1/8	29	1	40096-24	Dial, 12 AM Regen Assy, Black
7	1	13886	Knob, 3200			40096-02	Dial, 2 AM Regen Assy, Black
8	5	13296	Screw, Hex Wsh, 6-20 x 1/2	30	1	13881	Bracket, Hinger Timer
9	1	11999	Label, Button	31	2	11384	Screw, Phil, 6-32 x 1/4 Zinc
10	1	13018	Pinion, Idler	32	1	13902	Harness, 3200
11	1	13312	Spring, Idler Shaft	33	2	40422	Nut, Wire, Tan
12	1	13017	Gear, Idler	34	1	15354-01	Wire, Ground, 4 inches
13	1	13164	Gear, Drive	35	1	14007	Label, Time of Day
14	1	13887	Plate, Motor Mounting	36	1	*	Complete 3200 Time Clock Timer Assembly
15	1	18743-1	Motor, 120V, 60Hz, 1/30 RPM	37		60320-02	Switch Kit, 3200/9000 Timer Auxiliary, Optional
		18752-1	Motor, 100V, 50Hz, 1/30 RPM	38		61420-03	Program Wheel, Gear Assy, Filter 2 Min Per Pin
		18824-1	Motor, 230V, 50Hz, 1/30 RPM			61420-04	Program Wheel, Gear Assy, Softener, 2 Min Per Pin
		18826-1	Motor, 24V, 50Hz, 1/30 RPM				
		19659-1	Motor, 24V, 60Hz, 1/30 RPM				
		19660-1	Motor, 230V, 60Hz, 1/30 RPM				
16	2	13278	Screw, Slt'd Fillister Hd 6-32 x .156				
17	1	15424	Spring, Detent, Timer				
18	1	15066	Ball, 1/4-inch, Delrin				
19	1	15465	Label, Caution				
20	1	19210	Program Wheel Assy				
21	1	13911	Gear, Main Drive, Timer				
22	17	41754	Pin, Spring, 1/16 x 5/8 SS, Timer				
23	1	13011	Arm, Cycle Actuator				
24	1	13864	Ring, Skipper Wheel				

*Call your distributor for Part Number

3210 METER DELAYED TIMER ASSEMBLY

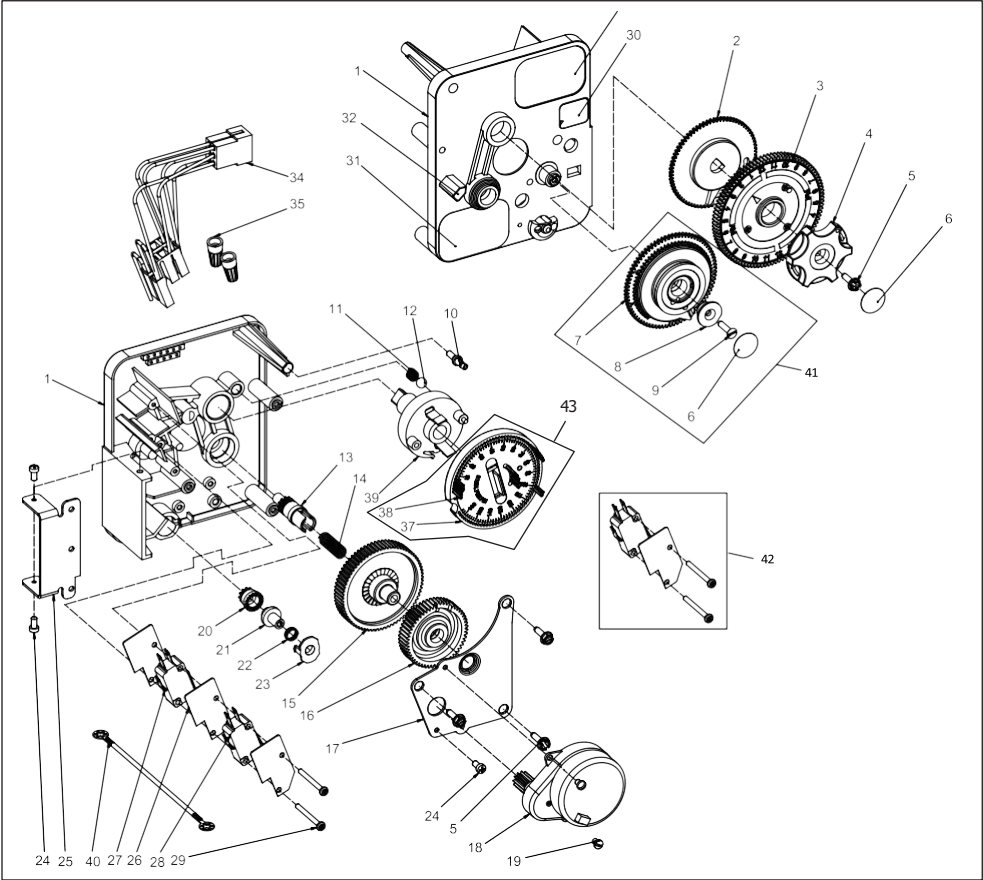

40

61502-3210 Rev A

3210 METER DELAYED TIMER ASSEMBLY

CONTINUED

Item No.	QTY	Part No.	Description	Item No.	QTY	Part No.	Description
1	1	13870	Housing, Timer, 3200	31	1	15465	Label, Caution
2	1	13802	Gear, Cycle Actuator	32	1	14007	Label, Time of Day
3	1	40096-02	Dial 2 AM Regen Assy, Black	33	1	14045	Label, Instruction
4	1	13886	Knob, 3200	34	1	13902	Harness, 3200
5	4	13296	Screw, Hex Wsh, 6-20 x 1/2	35	2	40422	Nut, Wire, Tan
6	2	11999	Label, Button	36	1	15354-01	Wire, Ground, 4 inches
7	1	13803	Gear, Program Drive Wheel	37	1	19210	Program Wheel Assy
8	1	13806	Retainer, Program Wheel	38	17	41754	Pin, Spring, 1/16 x 5/8 SS, Timer
9	1	13748	Screw, Flat Head St, 6-20 x 1/2	39	1	13911	Gear, Main Drive, Timer
10	1	14265	Clip, Spring	40	1	*	Complete 3210 Meter Delayed Timer Assembly
11	1	15424	Spring, Detent, Timer	41		60405-80	Program Wheel, w/3-inch STD Label 63,750 gal
12	1	15066	Ball, 1/4-inch Delrin			60405-90	Program Wheel, w/3-inch EXT Label 320,000 gal
13	1	13018	Pinion, Idler	42		60320-02	Switch Kit, 3200/9000 Timer Auxiliary, Optional
14	1	13312	Spring, Idler Shaft	43		61420-03	Program Wheel, Gear Assy, Filter 2 Min Per Pin
15	1	13017	Gear, Idler			61420-04	Program Wheel, Gear Assy, Softener, 2 Min Per Pin
16	1	13164	Gear, Drive	Not Shown:			
17	1	13887	Plate, Motor Mounting			25141	Label, STD M ³ , Gallon 240, 3-inch
18	1	18743-1	Motor, 120V, 60Hz 1/30 RPM			25142	Label, EXT M ³ , Gallon 1200, 3-inch
		18752-1	Motor, 100V, 50Hz, 1/30 RPM	*Call your distributor for Part Number			
		18824-1	Motor, 230V, 50Hz, 1/30 RPM				
		18826-1	Motor, 24V, 50Hz, 1/30 RPM				
		19659-1	Motor, 24V, 60Hz, 1/30 RPM				
		19660-1	Motor, 230V, 60Hz, 1/30 RPM				
19	1	13278	Screw, Fillister Hd, 6-32 x .156				
20	1	13830	Pinion, Program Wheel Drive				
21	1	13831	Clutch, Drive Pinion				
22	1	14276	Spring, Meter, Clutch				
23	1	14253	Retainer, Clutch Spring				
24	3	11384	Screw, Phil, 6-32 x 1/4				
25	1	13881	Bracket, Hinge Timer				
26	3	14087	Insulator				
27	1	10896	Switch, Micro				
28	1	15320	Switch, Micro, Timer				
29	2	11413	Screw, Pan Hd Mach, 4-40 x 1 1/8				
30	1	14198	Label, Indicator				

3220 METER IMMEDIATE TIMER ASSEMBLY

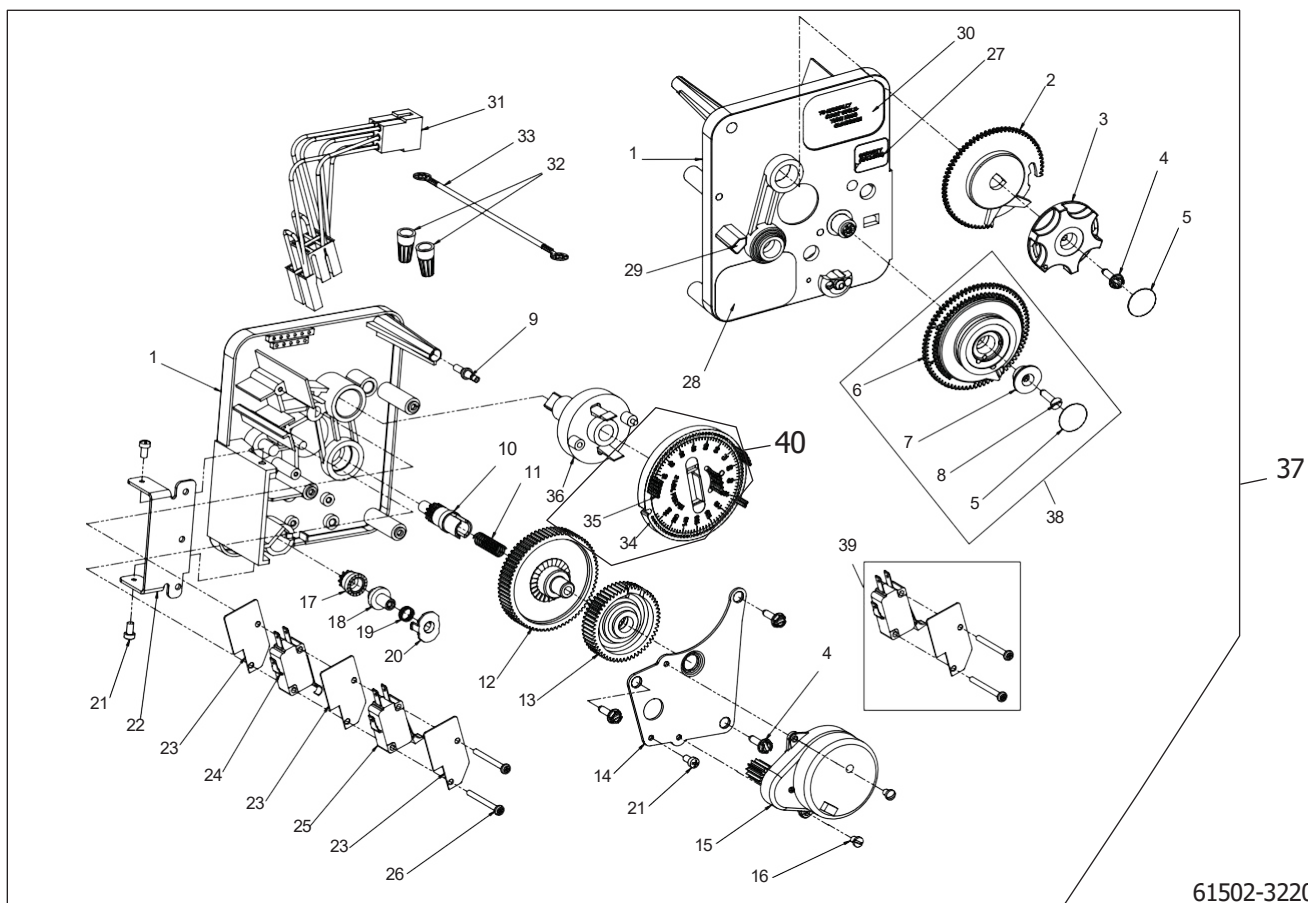

61502-3220 Rev B

3220 METER IMMEDIATE TIMER**ASSEMBLY CONTINUED**

Item No.	QTY	Part No.	Description	Item No.	QTY	Part No.	Description
1	1	13870	Housing, Timer	28	1	15465	Label, Caution
2	1	15431	Gear, Cycle Actuator, System #5	29	1	14007	Label, Time of Day
3	1	13886	Knob, 3200	30	1	15148	Label, Instruction
4	4	13296	Screw, Hex Wsh, 6-20 x 1/2	31	1	40617	Harness, 3220
5	2	11999	Label, Button	32	2	40422	Nut, Wire, Tan
6	1	13807	Gear, Program Drive Wheel	33	1	15354-01	Wire, Ground, 4 inches
7	1	13806	Retainer, Program Wheel	34	1	19210-05	Program Wheel Assembly, 9000/3230
8	1	13748	Screw, Flt Hd St, 6-20 x 1/2	35	17	41754	Pin, Spring, 1/16 x 5/8 Stainless Steel, Timer
9	1	14265	Spring Clip	36	1	15055	Gear, Main Drive
10	1	13018	Pinion, Idler	37	1	*	Complete 3220 Meter Immediate Timer Assembly
11	1	18563	Idler Shaft Spring	38		60405-80	Program Wheel, w/3-inch STD Label 63,750 gal
12	1	13017	Gear, Idler			60405-90	Program Wheel, w/3-inch EXT Label 320,000 gal
13	1	13164	Drive Gear	39		60320-02	Switch Kit, 3200/9000 Timer Auxiliary, Optional
14	1	13887	Plate, Motor Mounting	40		61420-06	Program Wheel, Gear Assy, Softener Immediate 2 Min Per Pin
15	1	18743-1	Motor, 120V, 60 Hz, 1/30 RPM			61420-42	Program Wheel, Gear Assy, Filter Immediate 2 Min Per Pin
		18752-1	Motor, 100V, 50Hz, 1/30 RPM				
		18824-1	Motor, 230V, 50Hz, 1/30 RPM				
		18826-1	Motor, 24V, 50Hz, 1/30 RPM				
		19659-1	Motor, 24V, 60Hz, 1/30 RPM				
		19660-1	Motor, 230V, 60Hz, 1/30 RPM				
16	2	13278	Screw, Slt'd Fillister Hd			25141	Label, STD M ³ , Gallon 240, 3-inch
17	1	14502	Pinion, Program Wheel			25142	Label, EXT M ³ , Gallon 1200, 3-inch
18	1	14501	Clutch, Drive Pinion				
19	1	14276	Meter Clutch Spring				
20	1	14253	Retainer, Clutch Spring				
21	3	11384	Screw, Phil, 6-32 x 1/4 Zinc				
22	1	13881	Bracket, Hinge Timer				
23	3	14087	Insulator				
24	1	15414-00	Micro Switch				
25	1	15320	Switch, Micro, Timer				
26	2	11413	Screw, Pan Hd Mach, 4-40 x 1-1/8				
27	1	14198	Label, Indicator				

Not Shown:

25141	Label, STD M ³ , Gallon 240, 3-inch
25142	Label, EXT M ³ , Gallon 1200, 3-inch

*Call your distributor for Part Number

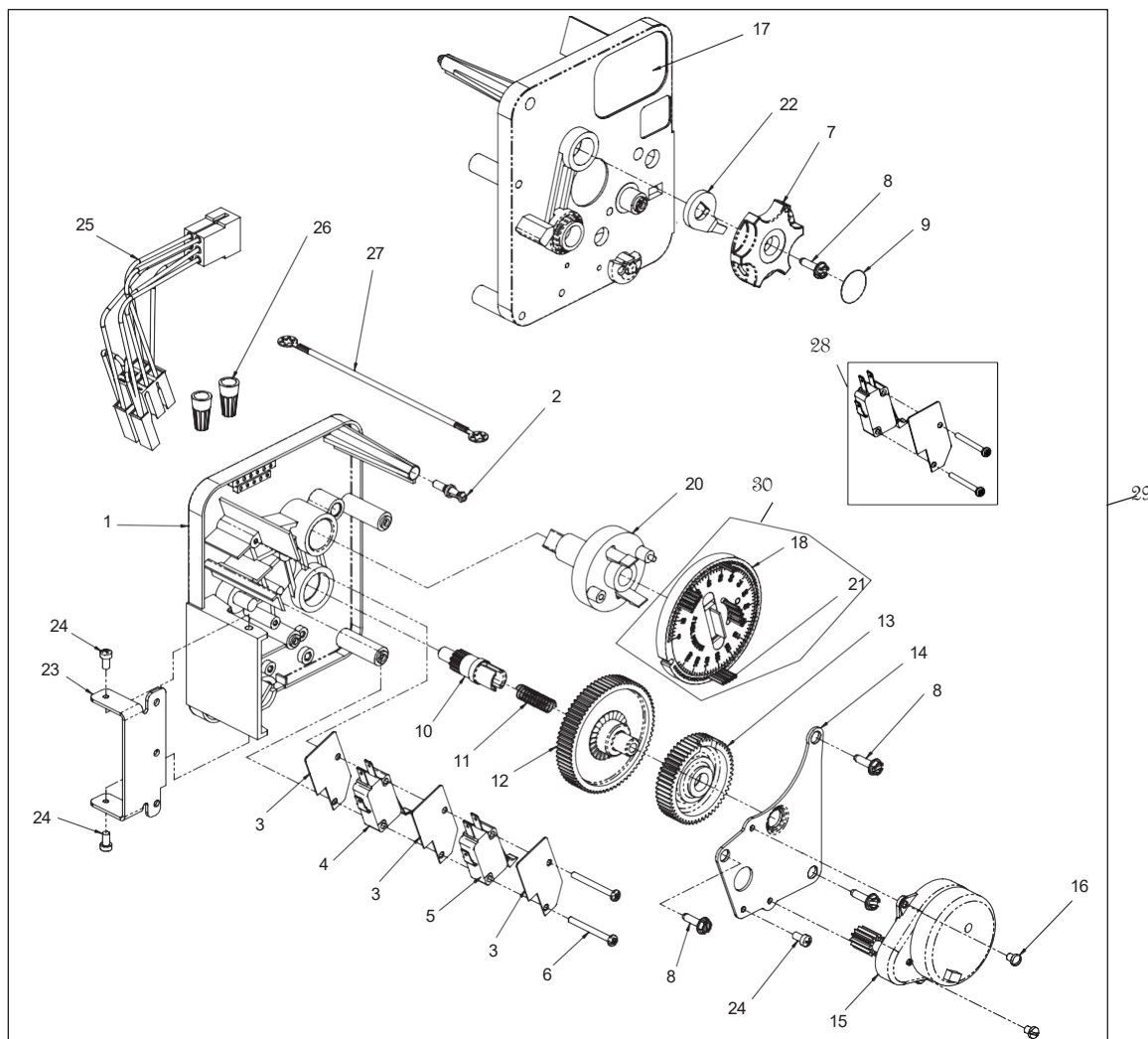
3230 REMOTE START TIMER ASSEMBLY

61502-3230R REV A

3230 REMOTE START TIMER ASSEMBLY

CONTINUED

Item No.	QTY	Part No.	Description	Item No.	QTY	Part No.	Description
1	1	13870	Housing, Timer	23	1	13881	Bracket, Hinge Timer
2	1	14265	Spring Clip	24	3	11384	Screw, Phil, 6-32 x 1/4 Zinc
3	3	14087	Insulator	25	1	16336	Harness, 3230R
4	1	15314	Micro Switch	26	2	40422	Nut, Wire, Tan
5	1	15320	Switch, Micro, Timer	27	1	15354-01	Wire, Ground, 4 inches
6	2	11413	Screw, Pan Hd Mach, 4-40 x 1-1/8	28		60320-02	Switch Kit, 3200/9000 Timer Auxiliary, Optional
7	1	13886	Knob, 3200	29		*	3230 Timer Assy
8	4	13296	Screw, Hex Wsh, 6-20 x 1/2	30		61420-06	Program Wheel, Gear Assy, Softener Immediate 2 Min Per Pin
9	1	11999	Label, Button			61420-42	Program Wheel, Gear Assy, Filter Immediate 2 Min Per Pin
10	1	13018	Pinion, Idler				
11	1	18563	Idler Shaft Spring				
12	1	13017	Gear, Idler				
13	1	15055	Drive Gear				
14	1	13887	Plate, Motor Mounting				
15	1	18743-1	Motor, 120V, 60 Hz, 1/30 RPM				
		18752-1	Motor, 100V, 50Hz, 1/30 RPM				
		18824-1	Motor, 23V, 50Hz, 1/30 RPM				
		18826-1	Motor, 24V, 50Hz, 1/30 RPM				
		19659-1	Motor, 24V, 60Hz, 1/30 RPM				
		19660-1	Motor, 230V, 60Hz, 1/30 RPM				
16	2	13278	Screw, Slted Fillister Hd				
17	1	15313	Label, Caution				
18	1	19210-05	Program Wheel Assembly, 3200				
20	1	15055	Main Drive Gear				
21	17	41754	Pin, Spring, 1/16 x 5/8 Stainless Steel, Timer				
22	1	13011	Cycle Actuator Arm				

*Call your distributor for Part Number

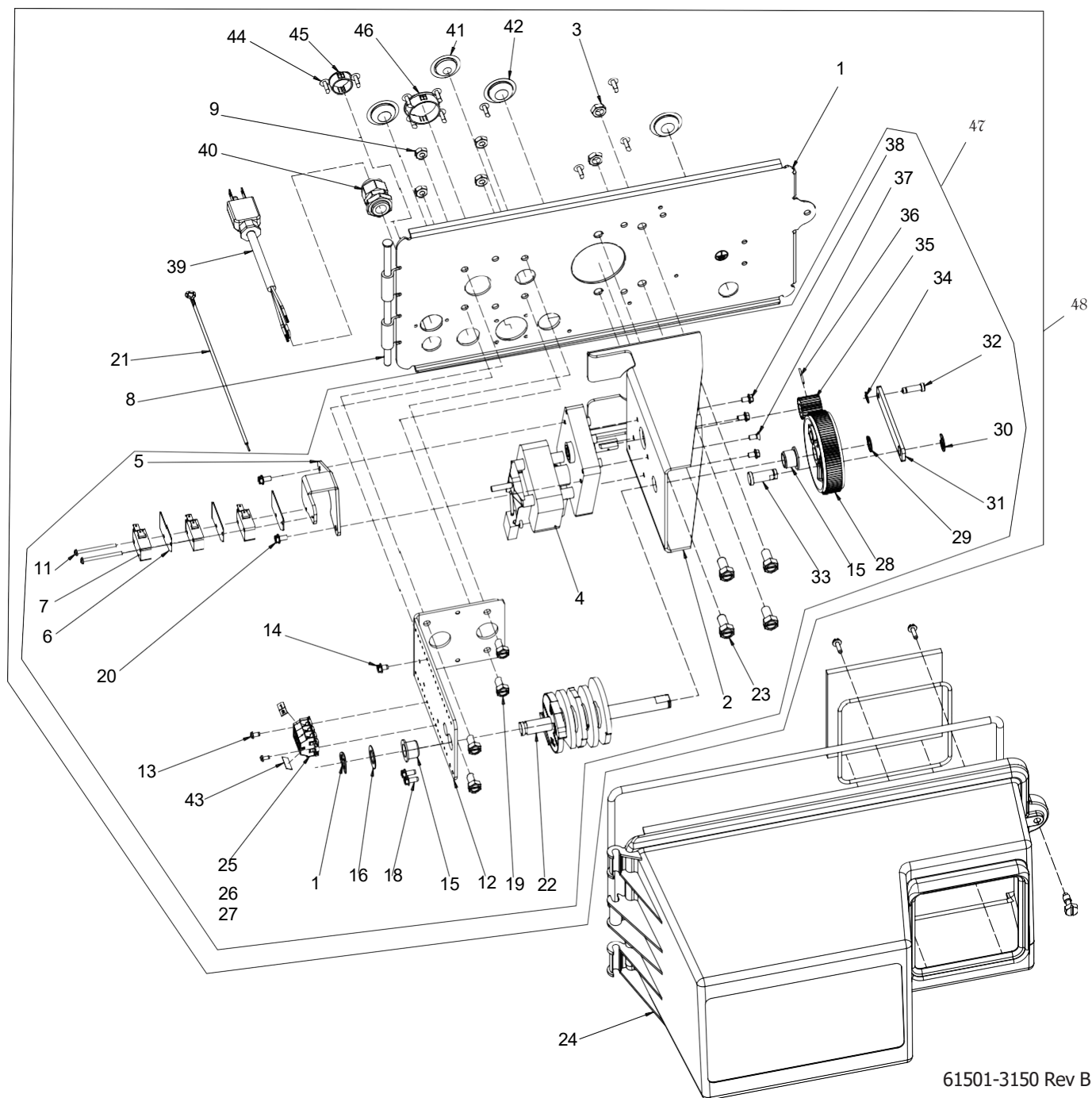
CONTROL DRIVE ASSEMBLY

CONTROL DRIVE ASSEMBLY CONTINUED

Item No.	QTY	Part No.	Description	Item No.	QTY	Part No.	Description
1	1	19304-04	Backplate, 3150/3900, Upper, NEMA 3R	31	1	16047	Link, Drive
2	1	15120-01	Bracket, Motor Mtg, 3150/3900 Environmental	32	1	11709	Pin, Drive Link
3	2	16346	Nut, Hex, Jam, 5/16 - 18	33	1	16048	Bearing, Drive Link
4	1	40392	Motor, Drive, 115V, 50/60 Hz, Sp	34	1	11898	Clip, 3150/3900
		40390	Motor, Drive, 220V, 50 Hz, Sp, Fam 3	35	1	16045	Pinion, Drive
		42581	Motor, Drive, 24VAC/DC, 50-60 Hz, Fam 3	36	1	11381	Pin, Roll, 2900/3900
5	1	17797	Bracket, Switch Mounting, 3150/3900	37	1	11080	Screw, Flt Hd Mach, 8-32 x 3/8
6	4	10302	Insulator, Limit Switch	38	3	10872	Screw, Hex Wsh, 8-32 x 17/64
7	3	10218	Switch, Micro	39	1	40084-12	Power Cord, 12 feet US, Round, 120V
8	1	17845-03	Pin, Hinge, 3150/3900, Env			40085-12	Power Cord, 12 feet US, Round, 240V
9	4	11235	Nut, Hex, 1/4 -20, Mach Screw, Zinc			11545	Power Cord, 4 feet European, Black
10	2	13365	Washer, Lock, #4, External			19303	Power Cord, 8 feet, Australian
11	2	40080	Screw, Rd Hd, 4-40 x 11-1 /2 inch			19885	Power Cord, Japanese, 110V/120V
12	1	16053	Bracket, Brine Side	40	1	17967	Fitting Assy, Liquid Tight, Blk
13	2	40133	Screw, Pan Hd, 4-40 x 1/4-inch	41	1	19691	Plug, .750 Dia, Recessed, Black
14	2	40133	Screw Pan HD, 4-40 x 1/4-inch	42	3	19591	Plug, .8750 Hole, Recessed, Black
15	2	16052	Bushing, 3150/3900	43	2	15250	Label, Terminal Strip
16	1	16059	Washer, SS, .88, 3150/3900	44	10	19800	Plug, .140 Dia, White
17	1	16051	Ring, Retaining, Bowed	45	1	15806	Plug, Hole, Heyco #2693
18	2	10300	Screw, Slot Hex Wsh, 18-8 x 3/8	46	1	17421	Plug, 1.20 Hole
19	4	10231	Screw, Slot Hex, 1/4 - 20 x 1/2	47		60057-01	Drive Assy, 3150, 120V, SYS 5 & 7, Signal After Brine Tank Fill
20	2	14202-01	Screw, Hex Wsh Hd, 8 x 5/16			60057-03	Drive Assy, 3150, 24V, 3900 Upper, SYS #5 or SYS #7
21	1	10475-01	Wire, Ground			60057-11	Drive Assy, 3150, 120V, 3900 Upper, SYS #4 or SYS #6
22	1	16494-03	Cam Assy, 3150/3900 Signal After Brine Fill			60057-21	Drive Assy, 3150, 120V, Upflow, 3900 Upper, SYS 5 or SYS 7, Brine Draw First
		16494-05	Cam Assy, 3150/3900 Upper Signal After Rapid Rinse	48		*	3150 Powerhead Assembly
		16494-06	Cam Assy, 3150/3900, Upper, Upflow, Signal After Rapid Rinse	Not Shown			
23	4	11224	Screw, Hex Hd, 5/16 - 18 x 5/8	1		17470	Cable Guide Assy, 2850/3150
24	1	60240-02	Cover Assy, 3150/3900 Env, Black, NEMA 3R	1		19856	Ring, Retaining (Used on Cover)
25	5	41084	Terminal Block, Segment, Gray	1			Timer (See Timer Section)
26	1	41085	Endplate, Terminal Block, Gray	1		16427-04	Wire, Lead, 12 inches, White
27	1	40174	Terminal Block, Green/Yellow	1		40396	Harness, Drive, Environmental
28	1	16046	Gear, Drive	1		14924	Strain Relief Heyco #1247
29	1	16050	Ring, Retaining	1		15513	Meter Cable, 17.5 inches, 2 inches
30	1	11774	Ring, Retaining	1		15216	Meter Cable, 15.25 inches, 1.5 inches
				1		18585	Harness, 3900, Aux Switch

*Call your distributor for Part Number

ADAPTER CONTROL DRIVE LOWER POWERHEAD

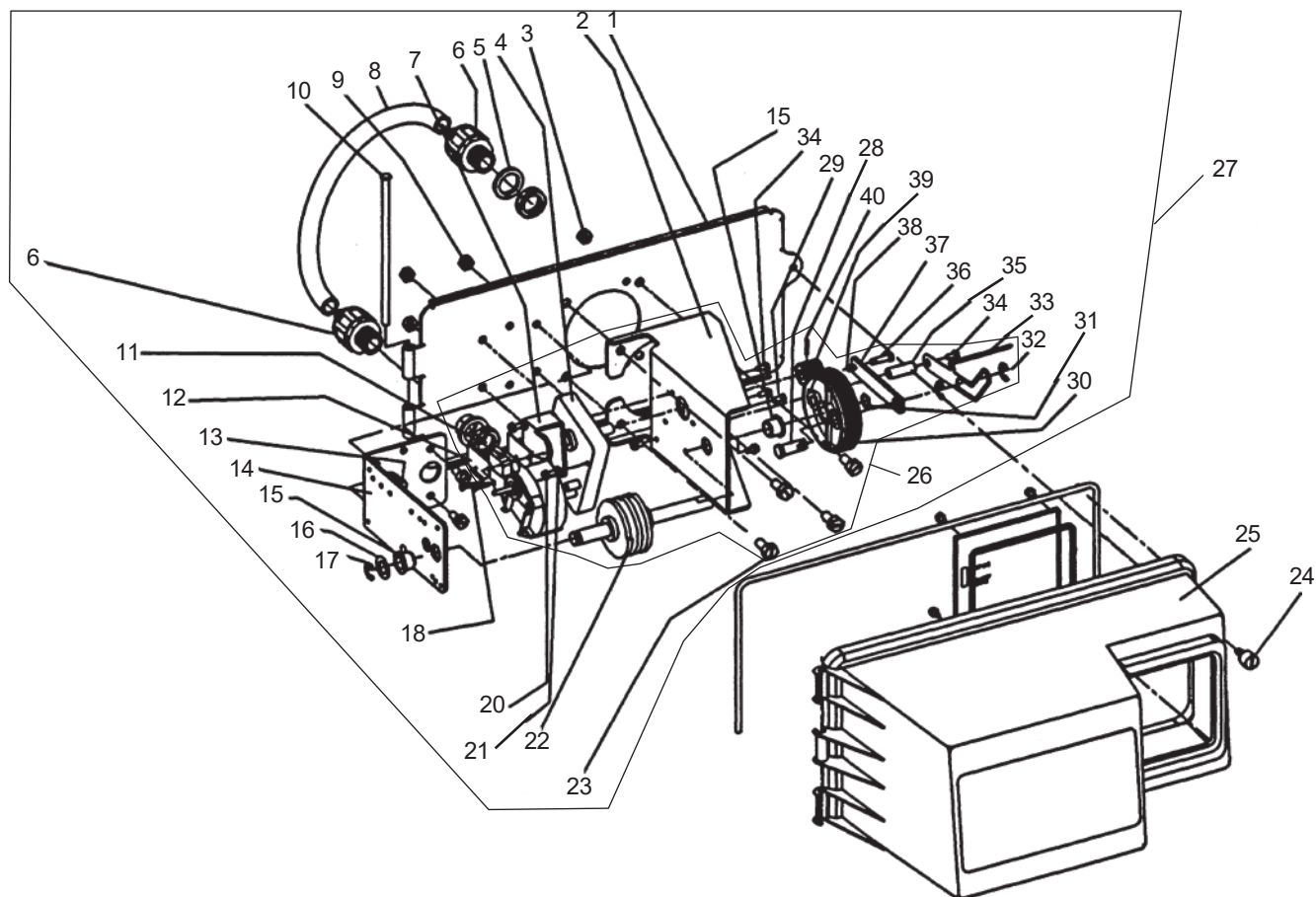

ADAPTER CONTROL DRIVE LOWER POWERHEAD *CONTINUED*

Item No.	QTY	Part No.	Description	Item No.	QTY	Part No.	Description
1	1	19305	Back Plate, 3900 Lower, Enviromental	26			Includes Item No: 2, 4, 7, 11, 12, 15, 18, 20, 21, 22, 23, 28, 29, 30, 31, 32, 33, 34, 35, 36, 37, 38, 39, 40
2	1	16086	Bracket - Motor Mounting			60058-01	Lower Drive Assy, 3900, 120V
3	2	16346	Nut			60058-03	Lower Drive Mtr Assy, 3900, 24V
4	1	40392	Drive Motor - 115 V. 50/60 Hz.	27	*		3900 Lower Powerhead Assy
		40390	Drive Motor - 220 V. 50/60 Hz.	28	1	16048-01	Bearing - Drive Link
		42581	Drive Motor - 24 VAC/DC 50/60 Hz.	29	2	11080	Screw - Flt HD Mach, 8-32 x 3/8, Steel Zinc
5	2	18692	Washer, Sealing	30	1	16046	Drive Gear
6	2	18691	Connector, Conduit	31	1	16050	Retaining Ring
7	1	17797	Bracket - Switch Mounting	32	2	11774	Retaining Ring - "E"
8	1	18693	Conduit, Interdrive	33	1	19315	Indicator
9	4	11235	Nut, 1/4-20	34	4	10872	Screw - Hex Head, 8-32 x 17/64, Steel/Trivalent Zinc
10	1	17845-03	Pin, Hinge	35	1	18726	Space, Indicator
11	1	10218	Switch	36	1	11709	Pin - Drive Link
12	2	10302	Insulator - Switch	37	1	16047	Drive Link
13	4	10231	Screw - Hex Head, 1/4-20 x 1/2, 18-8 S.S.	38	1	11898	Clip
14	1	16053	Bracket - Brine Side	39	1	16045	Drive Pinion
15	2	16052	Bushing	40	1	11381	Roll Pin
16	1	16059	Washer	Not Shown			
17	1	16051	Retaining Ring - Bowed "E"	1	40405		Wire Harness, Environmental, System 4, Lower
18	2	11805	Screw, RD HD, 4-40 x 5/8-inch, Type 1, Steel/Zinc	*Call your distributor for Part Number			
20	2	17567	Screw - Hex Head, WSH, 8 x 1/2, Type B, 18-8, S.S.				
21	2	12288	Washer, Lock, Internal #8				
22	1	16495	Cam Assembly				
23	4	11224	Screw - Hex Head, 5/16-18 x 5/8, S.S.				
24	1	19813/41536	Screw O-ring, Cover				
25	1	60240-22	Cover, Black, Lower, Environmental				

CONTROL VALVE

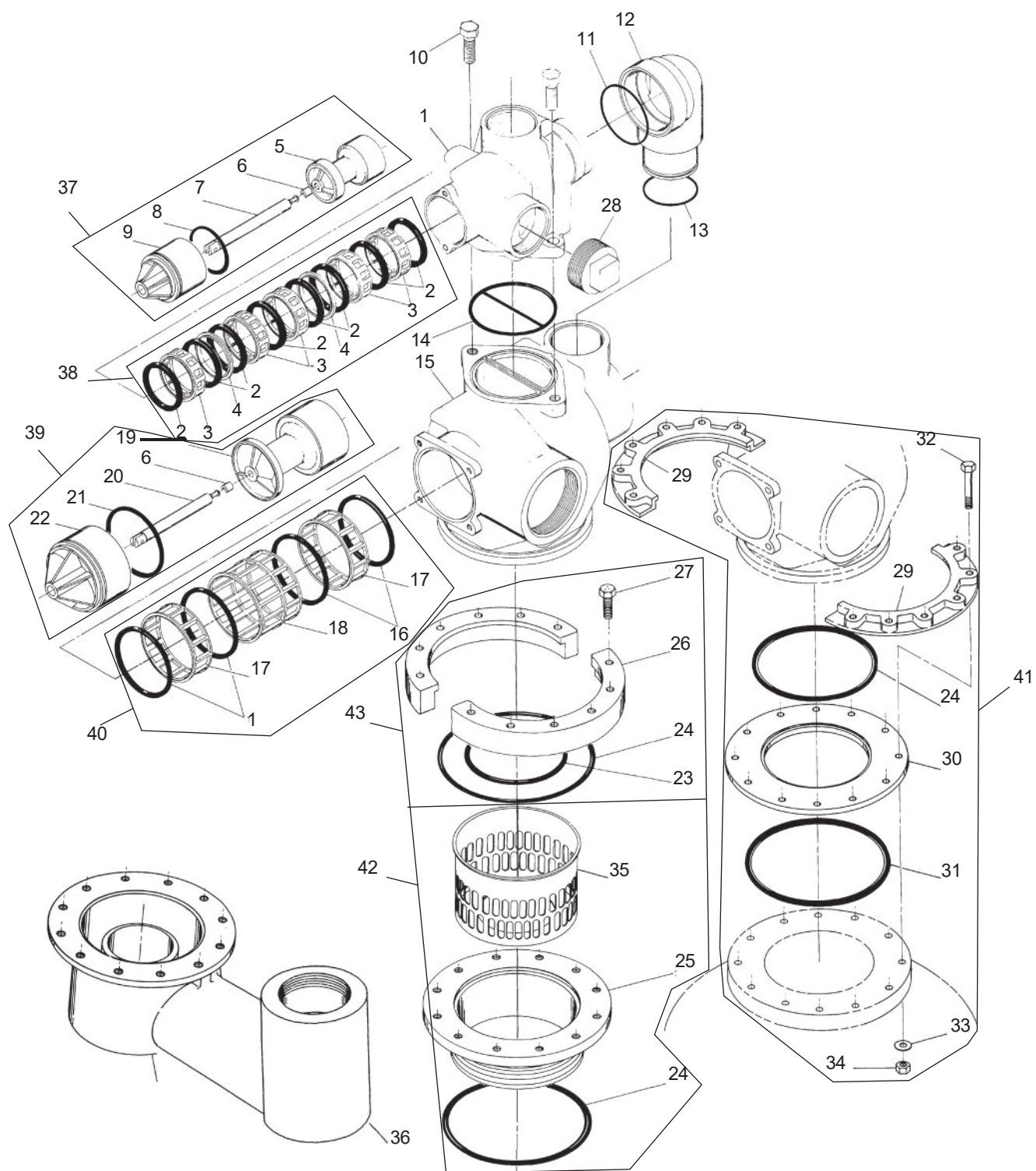

61500-3900

CONTROL VALVE CONTINUED

Item No.	QTY	Part No.	Description	Item No.	QTY	Part No.	Description
1	1	15114	Valve Body			60107-10	Piston Assy, 3900, NHWBP, Lower
2	8	11720	Seal	40		60132	Seal & Spacer Kit, 3900, Lower
		11720-02	Seal, Silicone			60132-10	Seal & Spacer Kit, 3900, 558BP Chemical Resistent, Lower
3	5	10369	Spacer - Port	41		60190	Flange Kit, Park & Structural, 09/05 and After
4	2	10368	Spacer			60191	Flange Kit, Park, 08/05 and Prior
5	1	16130	Piston	42		60193	Flange Kit, 6-inch Thread
6	2	14818	Clip - Piston Rod	43		60192	Flange Kit, Welded
7	1	15125	Piston Rod	Options			
8	1	14922	O-ring -035	29	2	16482	Flange Segment
9	1	16398-01	End Plug Assembly	30	1	16483	Flange Ring
10	2	40118	Screw - Hex Head	31	1	16484	O-Ring -442
11	1	16078	O-ring - 149	32	12	16517	Screw, Park Tank
12	1	16074	Coupling			19592	Screw, Structural Tank
13	1	16077	O-ring - 140	33	12	18619	Washer
14	1	15112	Seal	34	12	16346	Nut
15	1	16067-02	3-inch Adapter Body	36	1	18584	Adapter, Side Mount
16	4	16068	Seal				
		41534	Seal, 3900, 558 BP				
17	2	16069	Spacer - Narrow				
18	1	16070	Spacer - Wide				
19	1	16071	Piston				
		16082	Piston - No Hard Water Bypass				
20	1	16072	Piston Rod				
21	1	16076	O-ring - 042				
22	1	16399-01	End Plug Assy - White				
		16399-11	End Plug Assy - Black, NHWB-P				
23	1	16800	O-ring - 238				
24	2	16345	O-ring - 362				
25	1	16255	Tank Adapter - 6-inch -8				
26	2	16257	Flange Segment				
27	12	11238	Screw - Hex Head				
28	1	16088	Pipe Plug - 2-inch NPT				
35	1	16258	Flow Disperser				
37		60106-00	Piston Assy, 3900/3150 STD				
		60106-10	Piston Assy, 3150, Upflow				
38		60131	Seal & Spacer Kit, 3900 Upper, 3150				
		60131-10	Seal & Spacer Kit, Silicone, Chemical Resistent, 3900 Upper, 3150				
39		60107-00	Piston Assy, 3900, HWBP, Lower				

1800 SERIES BRINE SYSTEM AND DRAIN LINE FLOW CONTROL ASSEMBLY

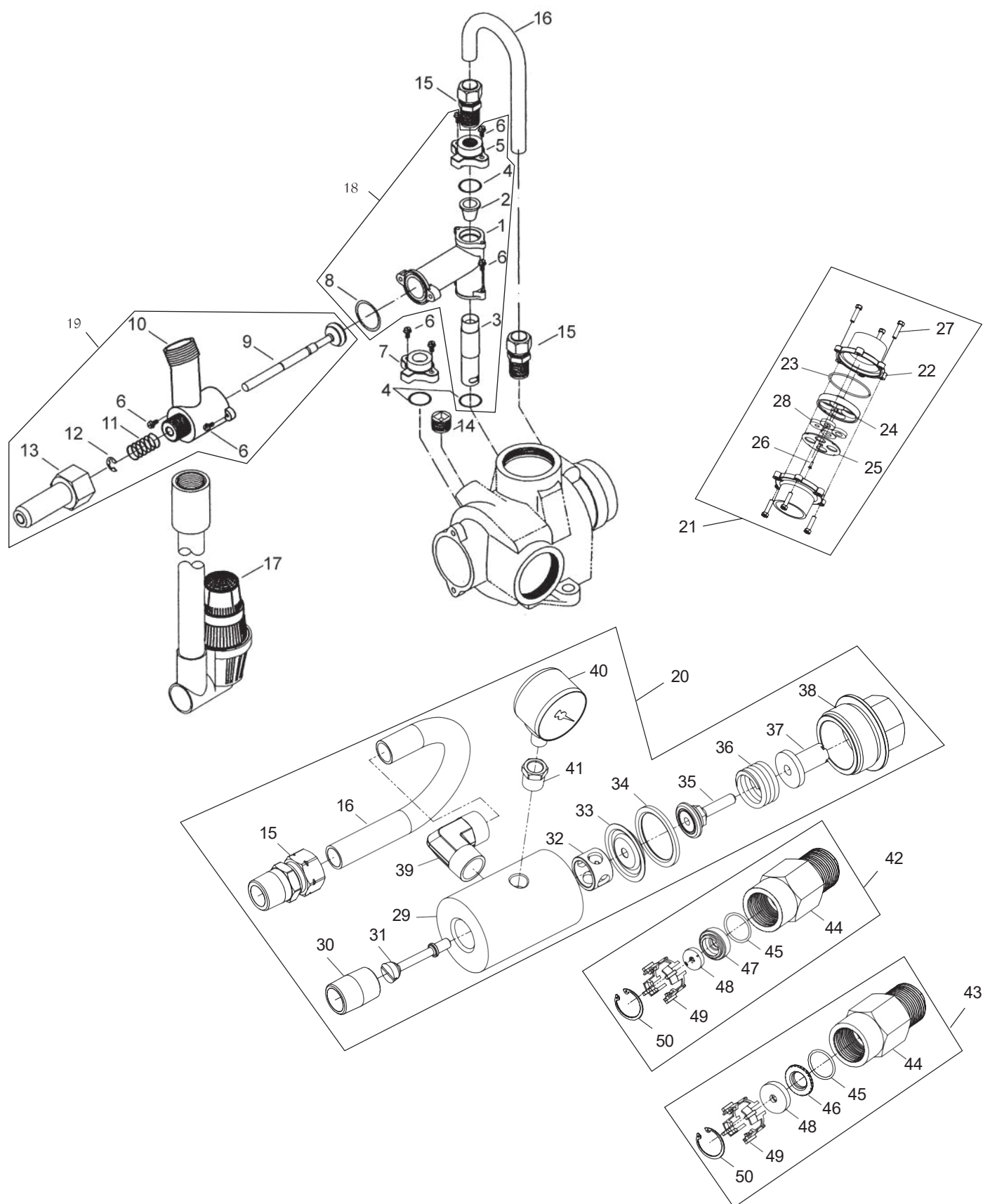

1800 SERIES BRINE SYSTEM AND DRAIN LINE FLOW CONTROL ASSEMBLY *CONTINUED*

Item No.	QTY	Part No.	Description	Item No.	QTY	Part No.	Description
1	1	16340	Body, Injector, 1800 D/F	15	2	18702	Fitting, Tube, 1/2 NPT 5/8
		16340-20	Body, Injector, 1800, Downflow, Metric	16	1	18703	Tube, Brine, 5/8 OD Annealed
		16340-01	Body, Injector, 1800 Upflow			18703-01	Tube, Brine, 5/8 OD, Short, Upflow
		16340-21	Body, Injector, 1800, Upflow, Metric	17	1	60009-00	Air Check, #900, Commercial Less Fittings
2	1	15128-xx	Injector Nozzle			60009-01	Air Check, #900, Commercial, HW Less Fittings
		15128-04	#4 Green	18		60277-04	Injector Assy, 1800, #4, Downflow
		15128-05	#5 Red			60272-04	Injectory Assy, 1800, #4, Upflow
		15128-06	#6 White			60277-05	Injectory Assy, 1800 #5, Downflow
		15128-07	#7 Blue			60272-05	Injector Assy, 1800, #5, Upflow
		15128-08	#8 Yellow			60277-06	Injector Assy, 1800, #6, Downflow
		15128-09	#9 Violet			60277-07	Injector Assy, 1800, #7, Downflow
		15128-10	#10 Black				
3	1	15127-xx	Injector Throat				
		15127-04	#4 Green				
		15127-05	#5 Red				
		15127-06	#6 White				
		15127-07	#7 Blue				
		15127-08	#8 Yellow				
		15127-09	#9 Violet				
		15127-10	#10 Black				
4	3	15246	O-ring, -116				
5	1	16341-01	Cap, Injector, 1800				
6	8	12473	Screw, Hex Wsh, 10-24 x 5/8				
7	1	16341-02	Plug, Injector, 1800				
8	1	19054	O-ring, -021, 560CD				
9	1	16497-01	Stem Assy, 1800, Brine Valve				
10	1	18713	Brine Valve Body, 1800				
11	1	11772	Spring, 3150 Brine Valve				
12	1	11774	Ring, Retaining				
13	1	16498-01	Stem Guide Assy, Brine				
14	1	16387	Plug, Pipe, 1/2-inch NPT				

1800 SERIES BRINE SYSTEM AND DRAIN LINE FLOW CONTROL ASSEMBLY *CONTINUED*

Item No.	QTY	Part No.	Description	Item No.	QTY	Part No.	Description
		60272-07	Injector Assy, 1800, #7, Upflow				70 gpm
		60277-08	Injector Assy, 1800, #8, Downflow	60812-75			DLFC, 2-inch BSP/Metric, 75 gpm
		60277-09	Injectory Assy, 1800 #9, Downflow	60812-80			DLFC, 2-inch BSP/Metric, 80 gpm
		60277-10	Injectory Assy, 1800 #10, Downflow	60812-90			DLFC, 2-inch BSP/Metric, 90 gpm
19		60036-02	Brine Valve, 1800, Design 3	60812-95			DLFC, 2-inch BSP/Metric, 95 gpm
		60276-01	Brine Valve, 1800, Retrofit Kit, Downflow 1800 Injector and Brine Valve, Update to Design 3	60812-100			DLFC, 2-inch BSP/Metric, 100 gpm
20		60734	Regulator, 3150/3900, Pressure, Upflow	22	2	27913-21	Housing, Flow Control, 2-inch BSP
21		60711-000	DLFC, 2-inch NPT, Less BTTNS, w/4 HLS	23		16804	O-ring, -150
		60711-00	DLFC, 2-inch NPT, Less BTTNS, W/2 HLS	24	1	16649	Holder, DLFC Button
		60711-01	DLFC, 2-inch NPT, Less BTTNS, W/1 HLS	25	1	16650	Cover Plate DLFC
		60711-20	DLFC, 2-inch NPT, 20 gpm	26	1	13898	Screw, Flat HD, Phil, Steel
		60711-25	DLFC, 2-inch NPT, 25 gpm	27	6	13386	Screw, Hex HD MACH, 1/4-20 x 1 OR Slot Hex Cap Screw 18-8 S.S.
		60711-30	DLFC, 2-inch NPT, 30 gpm			17976	Screw, Hex HD, M6 x 25 mm
		60711-35	DLFC, 2-inch NPT, 35 gpm	28		16529	Washer, Flow, 10.0 gpm
		60711-40	DLFC, 2-inch NPT, 40 gpm			16736	Washer, Flow, 15.0 gpm
		60711-45	DLFC, 2-inch NPT, 45 gpm			16528	Washer, Flow, 20.0 gpm
		60711-50	DLFC, 2-inch NPT, 50 gpm			16737	Washer, Flow, 25.0 gpm
		60711-55	DLFC, 2-inch NPT, 55 gpm	29	1	19089	Body Regulator 3150
		60711-60	DLFC, 2-inch NPT, 60 gpm	30	1	10242	Fitting, Nipple, 1/2-inch, Close
		60711-65	DLFC, 2-inch NPT, 65 gpm	31	1	19091	Pin, Regulator 3150
		60711-70	DLFC, 2-inch NPT, 70 gpm	32	1	19093	Stand-Off Regulator 3150
		60711-75	DLFC, 2-inch NPT, 75 gpm	33	1	19095	Diaphragm, Regulator 3150
		60711-80	DLFC, 2-inch NPT, 80 gpm	34	1	19094	Washer, Regulator 3150
		60711-85	DLFC, 2-inch NPT, 85 gpm	35	1	19092	Retainer, Regulator 3150
		60711-90	DLFC, 2-inch NPT, 90 gpm	36	1	19101	Spring, Regulator 3150
		60711-95	DLFC, 2-inch NPT, 95 gpm	37	1	19399	Washer, Calibration 3150
		60711-100	DLFC, 2-inch NPT, 100 gpm	38	1	19090	Cap, Regulator 3150
		60812-30	DLFC, 2-inch BSP/Metric, 30 gpm	39	1	19278	Fitting, Tube, 90 Deg
		60812-35	DLFC, 2-inch BSP/Metric, 35 gpm	40	1	19693	Pressure Gauge
		60812-45	DLFC, 2-inch BSP/Metric, 45 gpm	41	1	41232	Bushing Reducer 1/4 x 1/8
		60812-50	DLFC, 2-inch BSP/Metric, 50 gpm	42		60710-1.2	BLFC, 1-inch F x 1-inch M, NPT, 1.2 gpm
		60812-55	DLFC, 2-inch BSP/Metric, 55 gpm			60710-2.0	BLFC, 1-inch F x 1-inch M, NPT, 2.0 gpm
		60812-70	DLFC, 2-inch BSP/Metric,			60710-2.4	BLFC, 1-inch F x 1-inch M, NPT, 2.4 gpm
						60710-3.0	BLFC, 1-inch F x 1-inch M, NPT, 3.0 gpm
						60710-3.5	BLFC, 1-inch F x 1-inch M,

1800 SERIES BRINE SYSTEM AND DRAIN LINE FLOW CONTROL ASSEMBLY *CONTINUED*

Item No.	QTY	Part No.	Description
			NPT, 3.5 gpm
	60710-4.0	BLFC, 1-inch F x 1-inch M, NPT, 4.0 gpm
	60710-5.0	BLFC, 1-inch F x 1-inch M, NPT, 5.0 gpm
	60710-7.0	BLFC, 1-inch F x 1-inch M, NPT, 7.0 gpm
43		60710-9.0	BLFC, 1-inch F x 1-inch M, NPT, 9.0 gpm
	60710-10	BLFC, 1-inch F x 1-inch M, NPT, 10 gpm
	60710-12	BLFC, 1-inch F x 1-inch M, NPT, 12 gpm
	60710-15	BLFC, 1-inch F x 1-inch M, NPT, 15 gpm
	60710-20	BLFC, 1-inch F x 1-inch M, NPT, 20 gpm
	60710-25	BLFC, 1-inch F x 1-inch M, NPT, 25 gpm
44		16530	Housing, BLFC, 1"M x 1"F
45		19292	O-ring, -020
46		19279	Retainer, Flow Control, Flow 9.0 - 25 gpm
47		19053	Retainer, Flow Control, Flow 2.0 - 7.0 gpm
48		12085	Washer, Flow, 1.2 gpm
	12087	Washer, Flow, 2.0 gpm
	12088	Washer, Flow, 2.4 gpm
	12089	Washer, Flow, 3.0 gpm
	12090	Washer, Flow, 3.5 gpm
	12091	Washer, Flow, 4.0 gpm
	12092	Washer, Flow, 5.0 gpm
	12408	Washer, Fow, 7.0 gpm
	17944	Washer, Flow, 9.0 gpm
	16529	Washer, Flow, 10.0 gpm
	16735	Washer, Flow, 12.0 gpm
	16736	Washer, Flow, 15.0 gpm
	16528	Washer, Flow, 20.0 gpm
	16737	Washer, Flow, 25.0 gpm
49		16738	Retainer,Flow Control
50		16805	Ring, Retaining
Not Shown - Option Without Brine Valve			
	1	16605	Retainer Plate
	1	19860	Fitting, Brine Valve, 1800

3- INCH METER ASSEMBLY

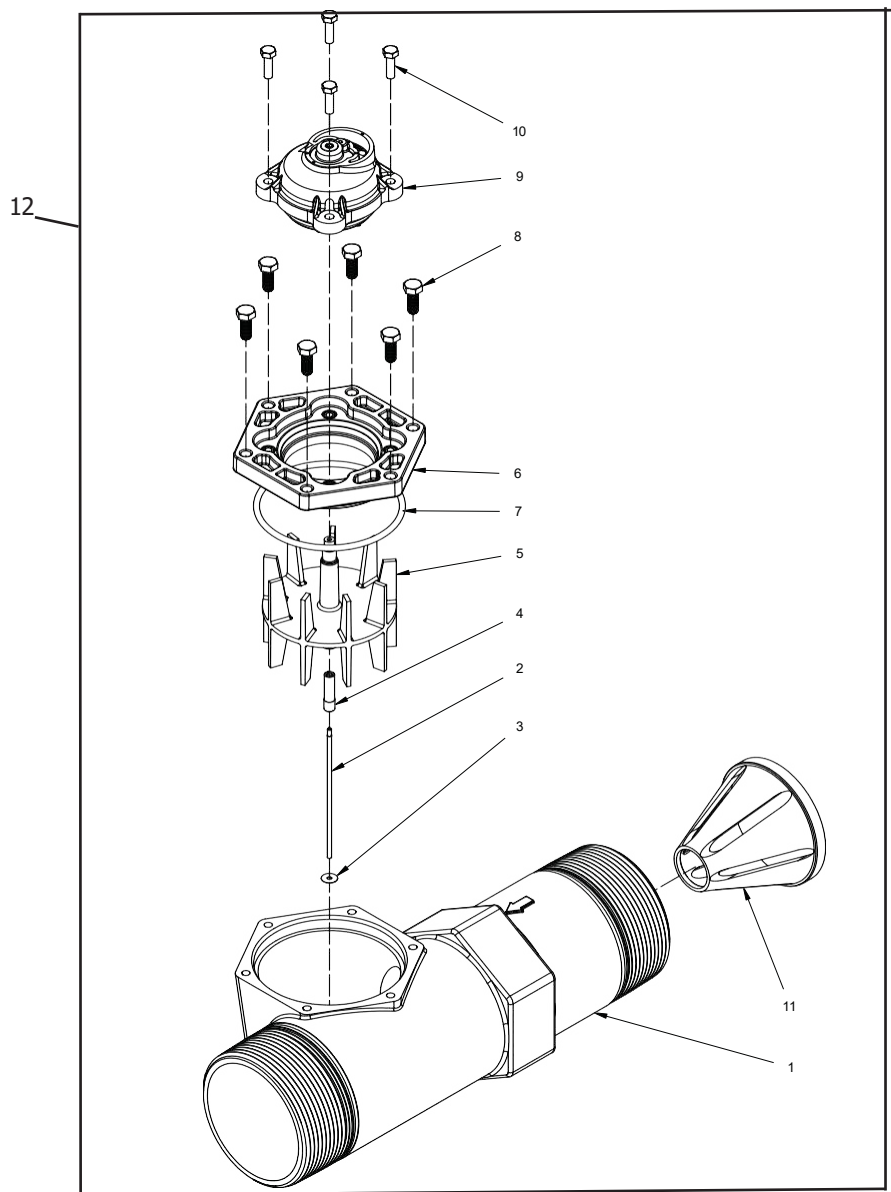

61935 Rev B

Item No.	QTY	Part No.	Description	Item No.	QTY	Part No.	Description
1	1	43787-10	Body, Meter, 3", SS, NPT	11	1	16280	Flow Straightener, 3"
	1	43787-20	Body, Meter, 3", SS, BSP	12		61935-10	Meter Assy, 3" INLN, SS, NPT STD
2	1	16279	Shaft, Impeller			61935-11	Meter Assy, 3" INLN, SS, NPT EXT
3	1	16574	Washer, Plain, SS			61935-20	Meter Assy, 3" INLN, SS, BSP STD
4	1	15381	Plug, Impeller			61935-21	Meter Assy, 3" INLN, SS, BSP STD
5	1	16252-01	Impeller, 3900, PP				
6	1	43982	Meter Plate, 3"				
7	1	15707	O-Ring, -236				
8	6	44074	Screw - Hex HD, M6X16MM, SS				
9	1	61936	Meter Cap ASSY				
		61936-01	Meter Cap ASSY, EXT Range				
10	4	21716	Screw, Hex Head, MS X 16				

SERVICE VALVE OPERATOR ASSEMBLY

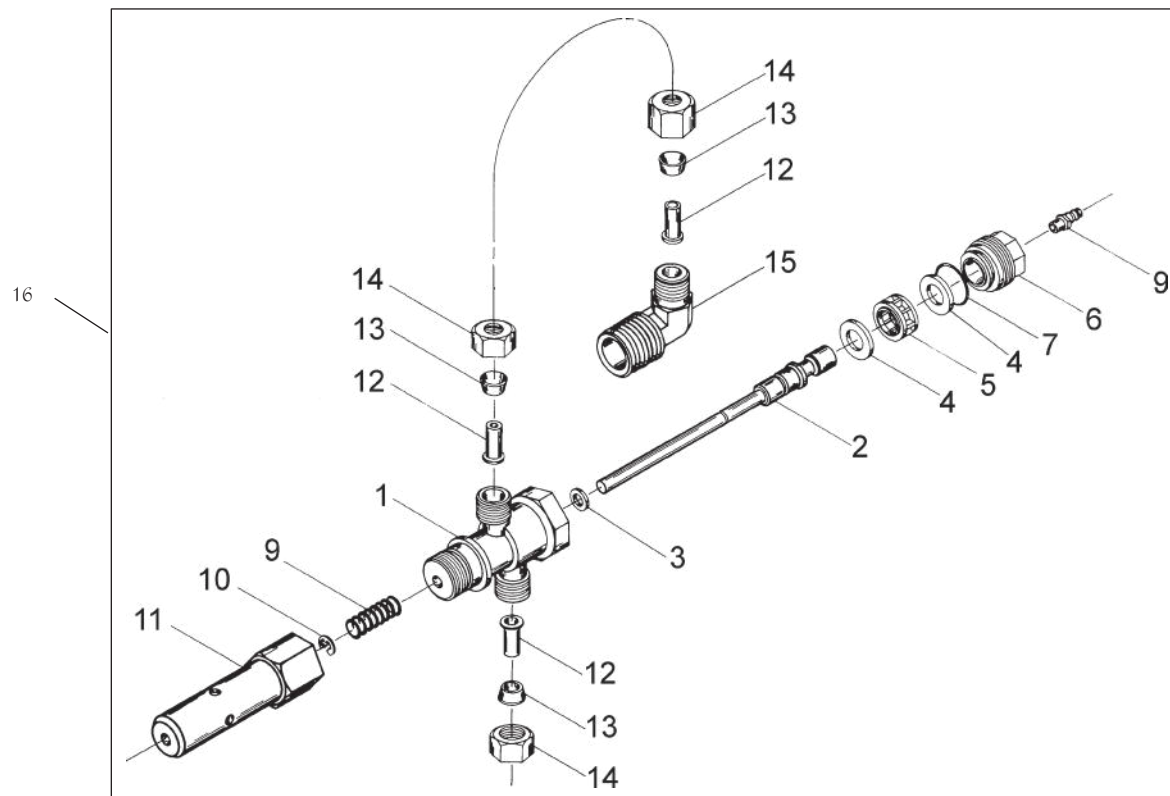

BR60150-3150REVA

Item No.	QTY	Part No.	Description
1	1	15074	Body, SVO
2	1	16065	Piston & Stem, SVO
3	1	10141	O-ring, -010
4	2	14835	Seal, 3150
5	1	14834	Spacer, Softwater Fill
6	1	16509	Plug, End, SVO
7	1	12977	O-ring, -015
8	1	15965	Fitting, Bias
9	1	10249	Spring, Brine Valve
10	1	10250	Ring, Retaining
11	1	16498-02	Stem Guide Assy, SVO
12	3	10332	Fitting, Insert, 3/8
13	3	10330	Fitting, Sleeve, 3/8 Celcon
14	3	10329	Fitting, Tube, 3/8 Nut, Brass
15	1	16503	Fitting, Elbow, 90 Deg.
16	1	60150-3150	SVO Assy, 3150/3900 (Includes Items 1-15)

Not Shown

.....11	16511	Tube, 3150, PVC, SVO
--------	--------	-------	----------------------

TROUBLESHOOTING

Problem	Cause	Correction
Water conditioner fails to regenerate.	Electrical service to unit has been interrupted	Assure permanent electrical service (check fuse, plug, pull chain, or switch)
	Timer is defective.	Replace timer.
	Power failure.	Reset time of day.
Hard water.	By-pass valve is open.	Close by-pass valve.
	No salt is in brine tank.	Add salt to brine tank and maintain salt level above water level.
	Injector screen plugged.	Clean injector screen.
	Insufficient water flowing into brine tank.	Check brine tank fill time and clean brine line flow control if plugged.
	Hot water tank hardness.	Repeated flushings of the hot water tank is required.
	Leak at distributor tube.	Make sure distributor tube is not cracked. Check o-ring and tube pilot.
	Internal valve leak.	Replace seals and spacers and/or piston.
Unit used too much salt.	Improper salt setting.	Check salt usage and salt setting.
	Excessive water in brine tank.	See "Excessive water in brine tank".
Loss of water pressure.	Iron buildup in line to water conditioner.	Clean line to water conditioner.
	Iron buildup in water conditioner.	Clean control and add mineral cleaner to mineral bed. Increase frequency of regeneration.
	Inlet of control plugged due to foreign material broken loose from pipes by recent work done on plumbing system.	Remove piston and clean control.
Loss of mineral through drain line.	Air in water system.	Assure that well system has proper air eliminator control. Check for dry well condition.
	Improperly sized drain line flow control.	Check for proper drain rate.
Iron in conditioned water.	Fouled mineral bed.	Check backwash, brine draw, and brine tank fill. Increase frequency of regeneration. Increase backwash time.
Excessive water in brine tank.	Plugged drain line flow control.	Clean flow control.
	Plugged injector system.	Clean injector and screen.
	Timer not cycling.	Replace timer.
	Foreign material in brine valve.	Replace brine valve seat and clean valve.
	Foreign material in brine line flow control.	Clean brine line flow control.
Softener fails to draw brine.	Drain line flow control is plugged.	Clean drain line flow control.
	Injector is plugged.	Clean injector
	Injector screen plugged.	Clean screen.
	Line pressure is too low.	Increase line pressure to 20 psi
	Internal control leak	Change seals, spacers, and piston assembly.
	Service adapter did not cycle.	Check drive motor and switches.
Control cycles continuously.	Misadjusted, broken, or shorted switch.	Determine if switch or timer is faulty and replace it, or replace complete power head.
Drain flows continuously.	Valve is not programming correctly.	Check timer program and positioning of control. Replace power head assembly if not positioning properly.
	Foreign material in control.	Remove power head assembly and inspect bore. Remove foreign material and check control in various regeneration positions.
	Internal control leak.	Replace seals and piston assembly.

GENERAL SERVICE HINTS FOR METER CONTROL

Problem: Softener delivers hard water

Reason: Reserve capacity has been exceeded.

Correction: Check salt dosage requirements and reset program wheel to provide additional reserve.

Reason: Program wheel is not rotating with meter output.

Correction: Pull cable out of meter cover and rotate manually. Program wheel must move without binding and clutch must give positive clicks when program wheel strikes regeneration stop. If it does not, replace timer.

Reason: Meter is not measuring flow.

Correction: Check meter with meter checker.

WATER CONDITIONER FLOW DIAGRAMS

1 Service Position

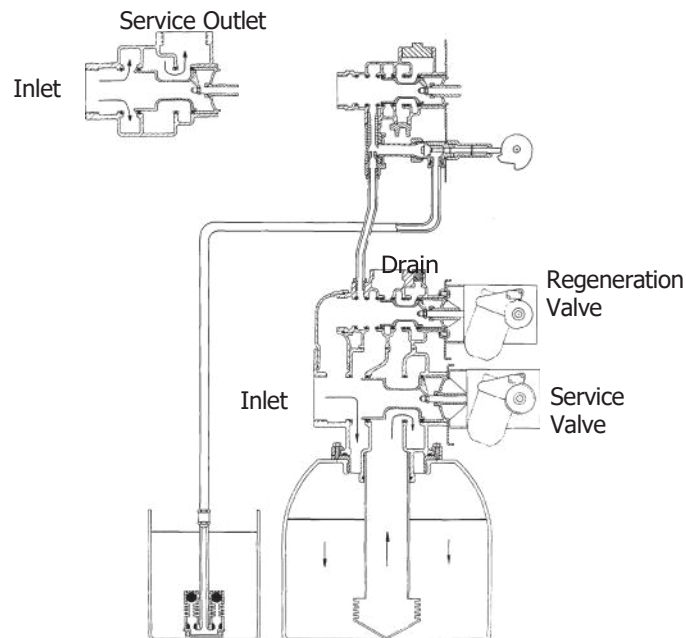

Hard water enters at valve inlet and flows down thru mineral to the bottom distributor. Conditioned water flows up thru the distributor tube, around the piston and out the outlet.

2 Backwash Position

No Hard Water Bypass

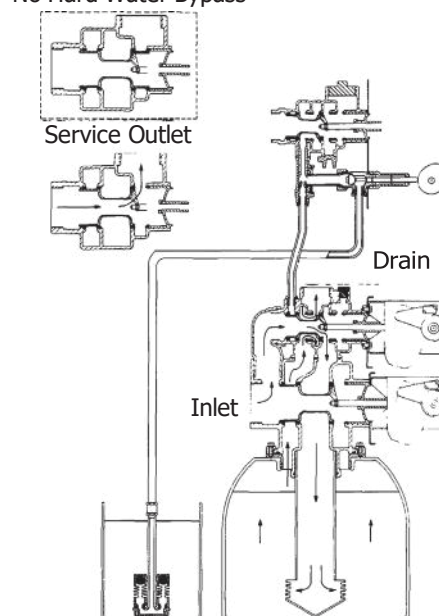

Hard water enters at valve inlet – flows thru service adapter piston for by-pass, and up thru coupling to regeneration valve inlet. Flow continues thru the regeneration valve piston – down the distributor tube – thru the bottom distributor and up thru the mineral – around the piston and out the drain. If optional no hard water by-pass piston is used, water flow to service outlet is prevented by an extension on the service outlet until the end of the rapid rinse cycle or brine tank refill cycle, depending on options chosen.

WATER CONDITIONER FLOW DIAGRAMS

CONTINUED

3 Brine Position

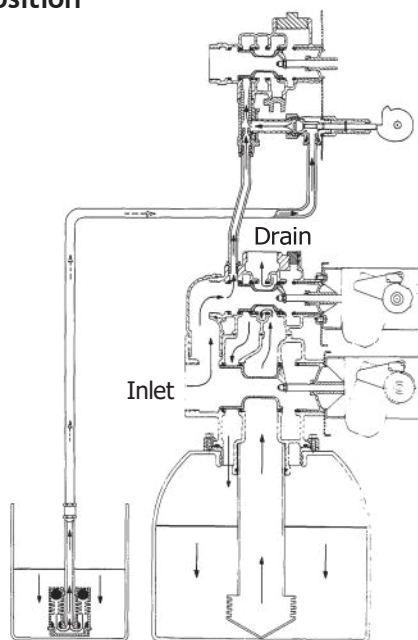

Hard water enters at valve inlet – flows thru injector nozzle and throat to draw brine from the brine tank. Brine flows down thru the mineral – into the bottom distributor – up the distributor tube – around the piston and out the drain.

4 Slow Rinse Position

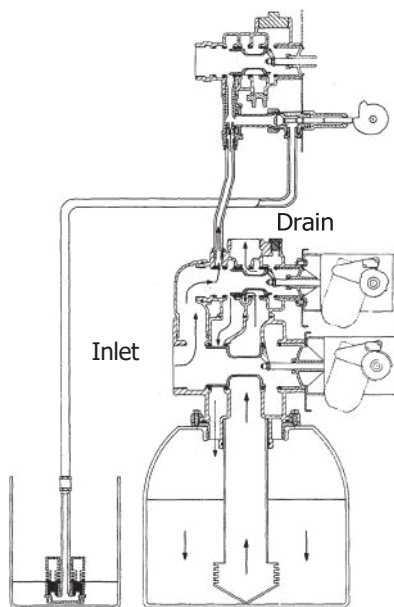

Hard water enters at valve inlet – flows thru injector nozzle and throat – down thru the mineral – into the bottom distributor – up the distributor tube – around the piston and out the drain.

5 Rapid Rinse Position

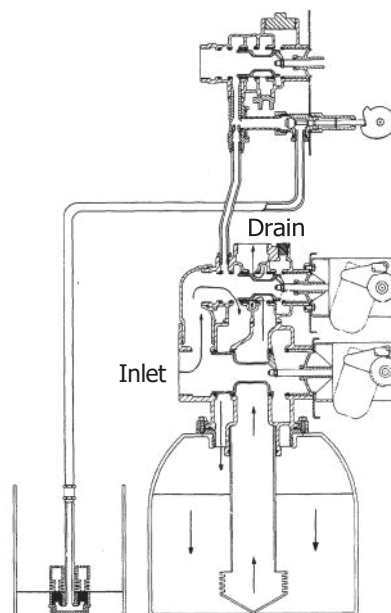

Hard water enters at valve inlet – flows thru the regeneration valve directly down thru the mineral – into the bottom distributor – up the distributor tube – around the piston and out the drain.

6 Brine Tank Refill Position

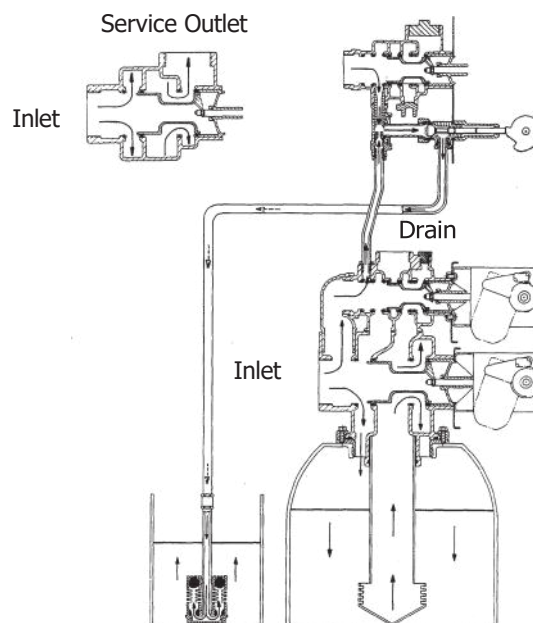

Hard water enters at valve inlet – flows thru nozzle and thru throat to brine valve to refill the brine tank. Inlet flow also continues down thru mineral to the bottom distributor. Conditioned water flows up thru the distributor tube, around the piston and out the outlet. Note: An option is available to keep service valve in by-pass position until the end of brine tank refill cycle.

DIMENSIONAL DRAWING 3900 TOP MOUNT

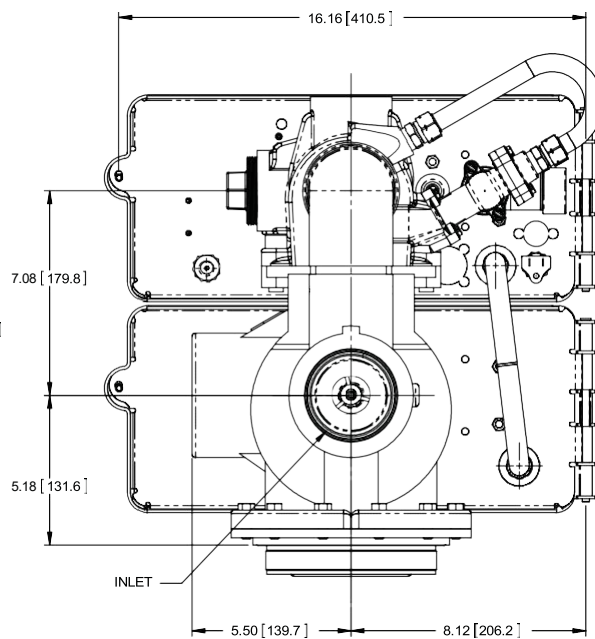
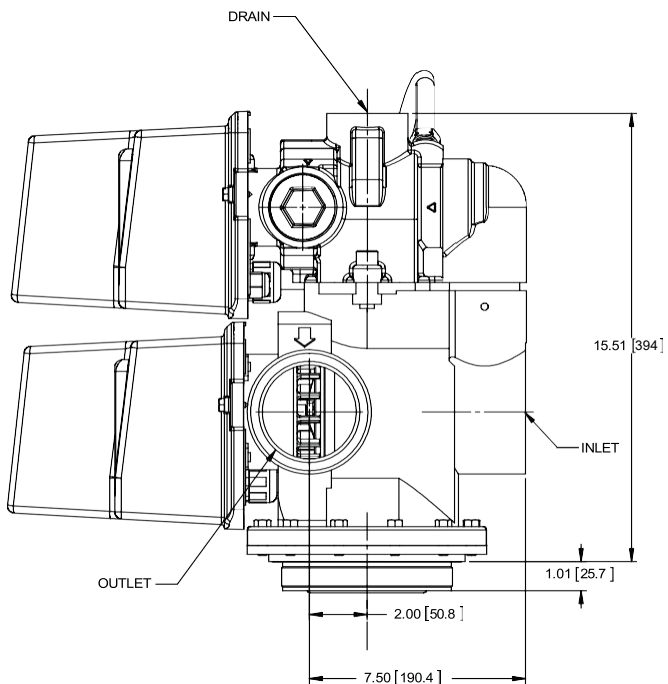
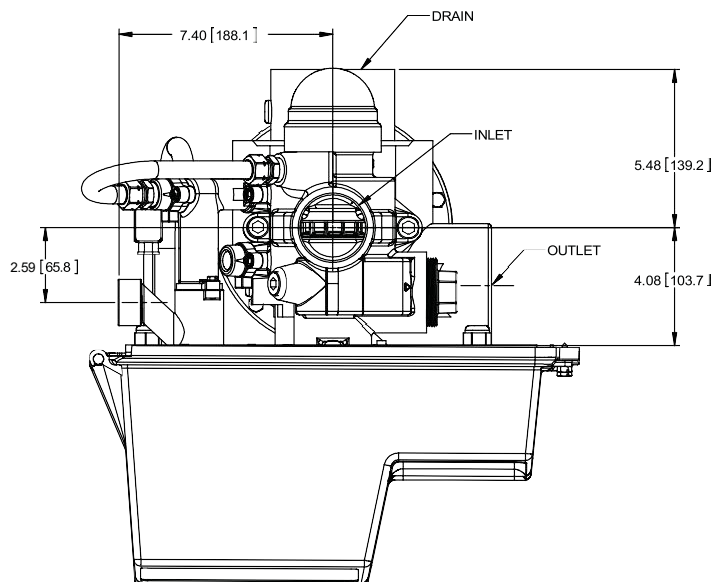
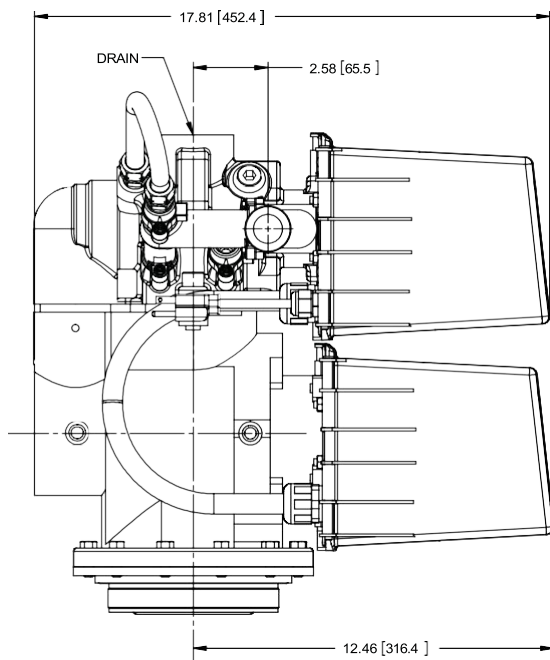

DIMENSIONAL DRAWING 3900 SIDE MOUNT

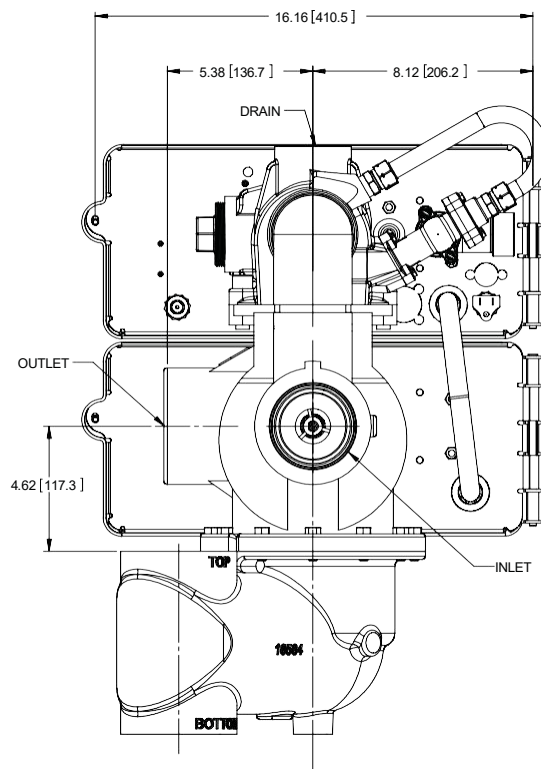
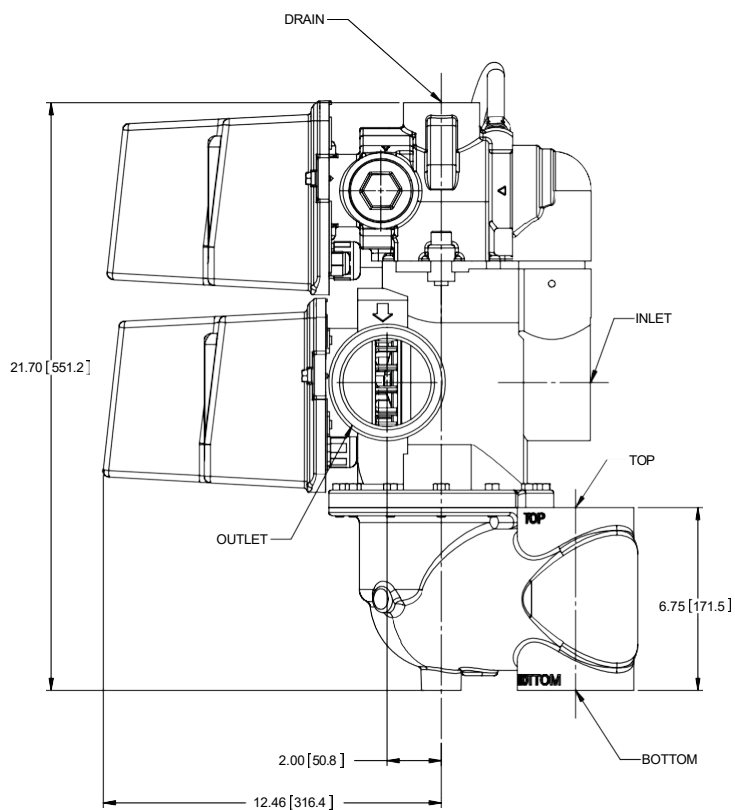
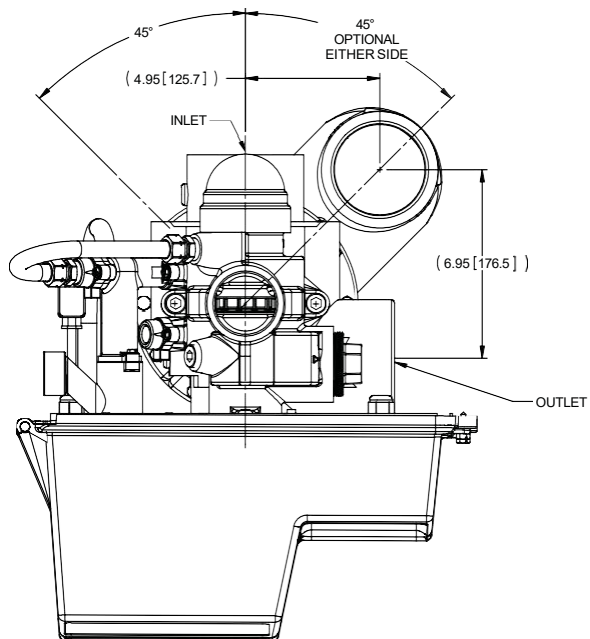

TYPICAL INSTALLATIONS

System #4 - Typical Single Tank Installation with Optional Meter

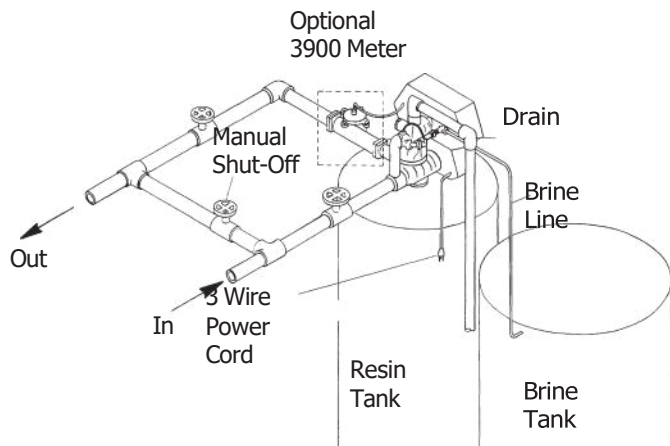

System #5 Interlock - Typical Twin Tank Installation with Optional Meter Interlock and No Hard Water Bypass

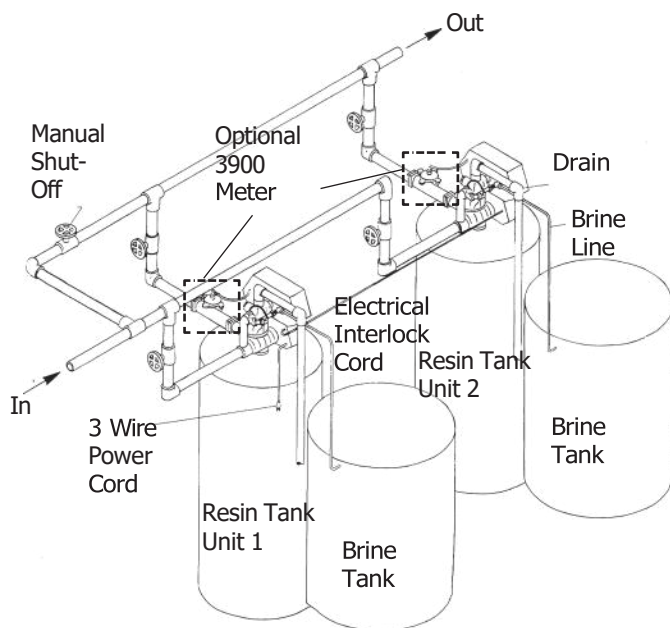

System #6 Interlock - Typical Twin Tank Installation with Optional Meter Interlock and No Hard Water Bypass

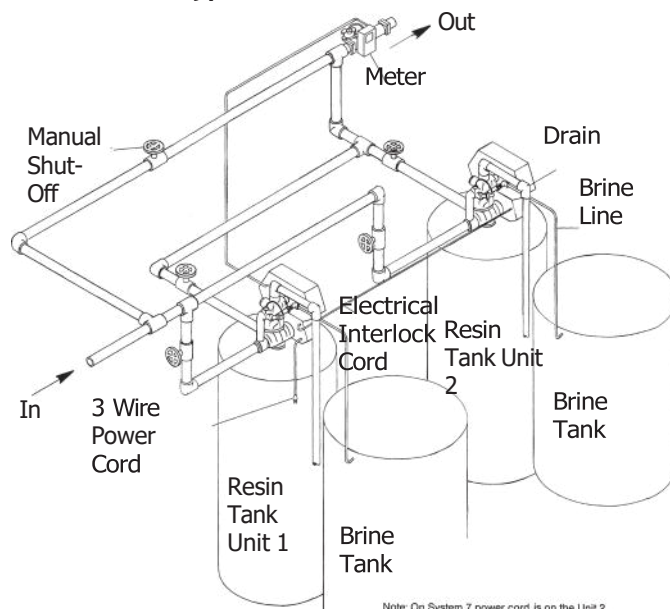

Note: On System 7 power cord is on the Unit 2.

VALVE WIRING

System #4

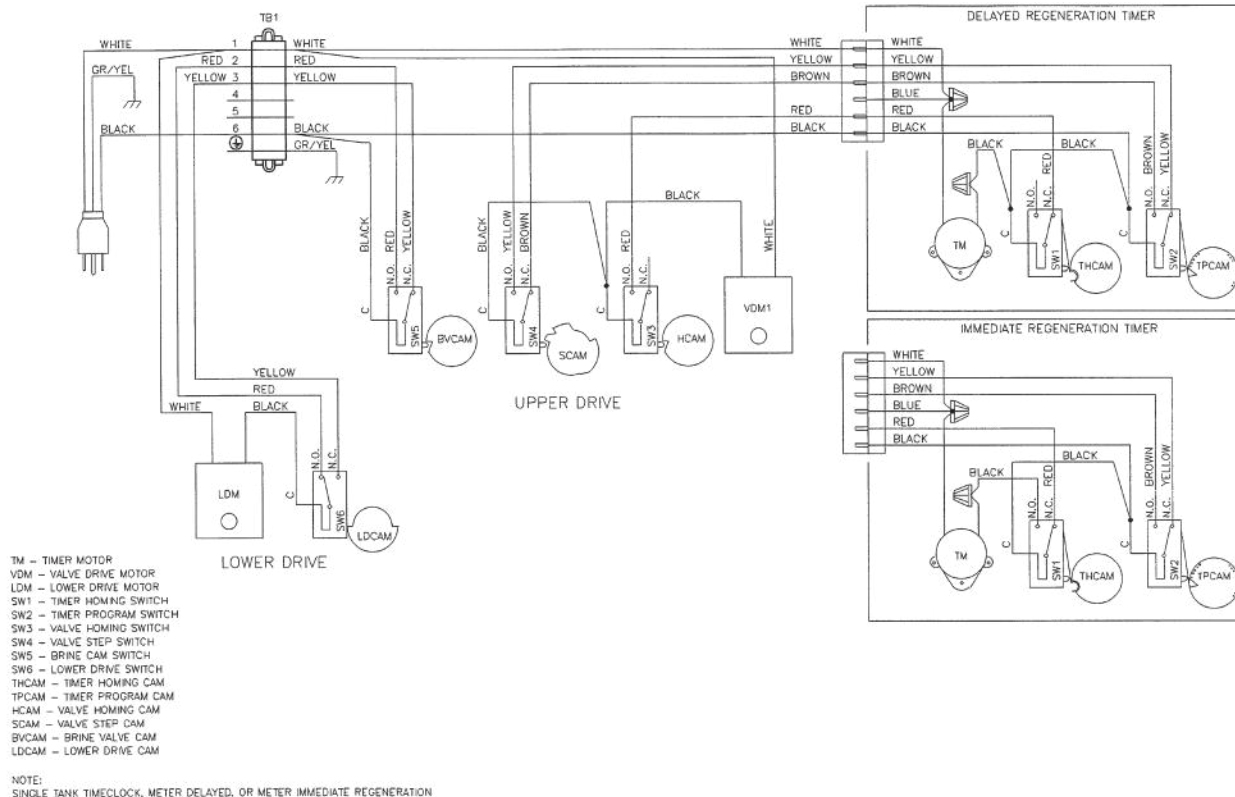

System #4 with Remote Meter

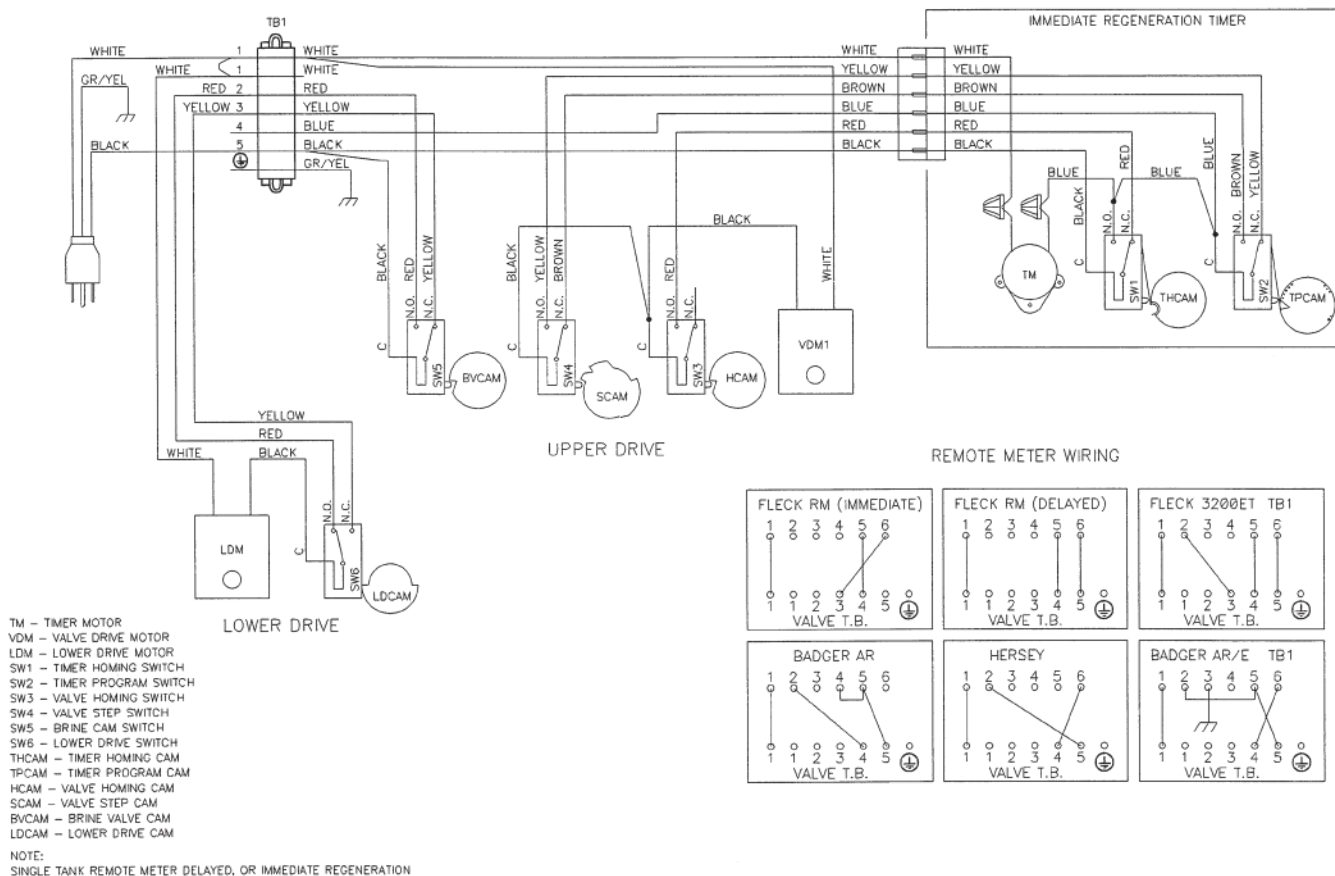

VALVE WIRING CONTINUED

System #5

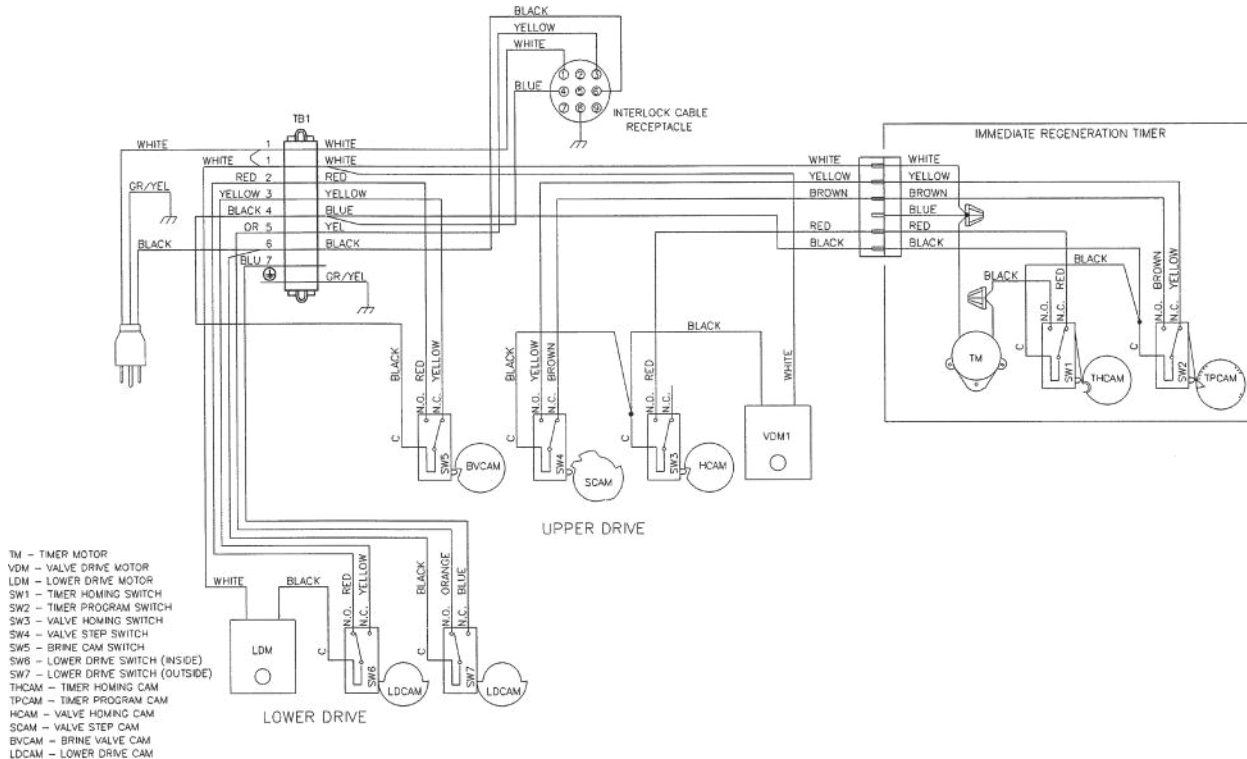

NOTE:
TWO TANK INTERLOCKED, INDIVIDUAL METER, IMMEDIATE REGENERATION.
ONLY ONE TANK IN REGENERATION THE OTHER IN SERVICE.

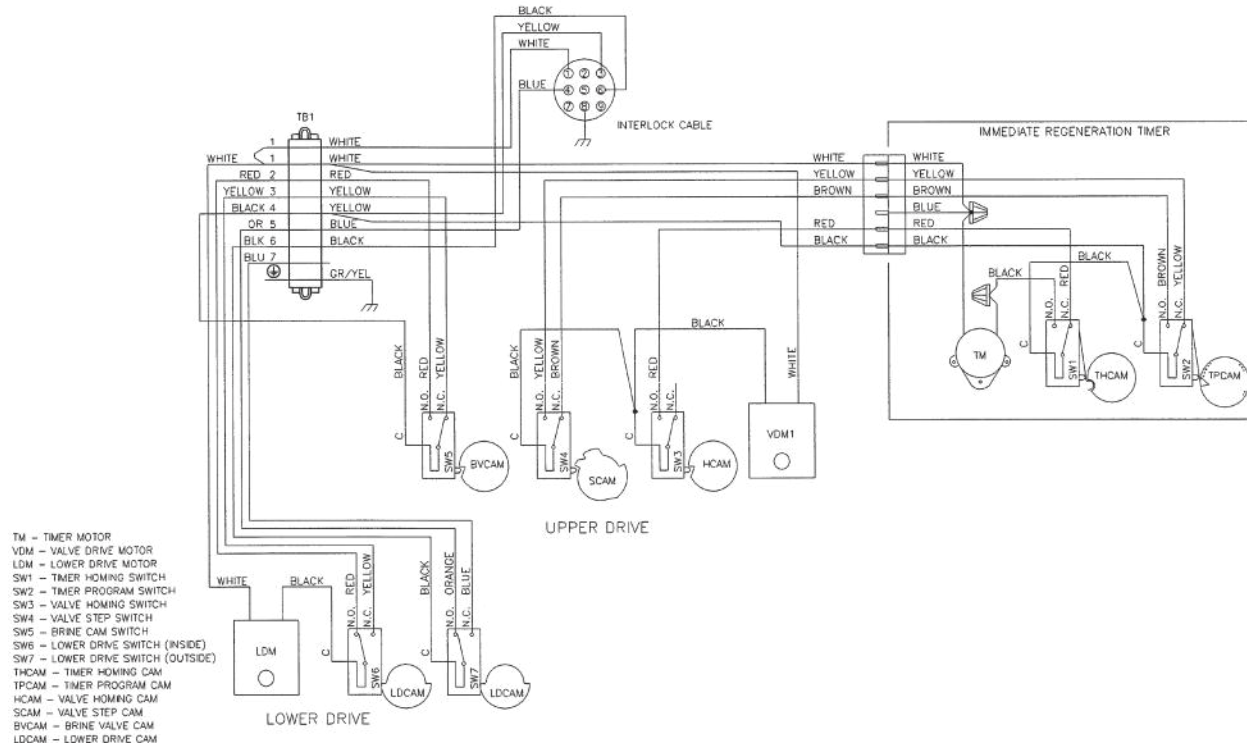

VALVE WIRING CONTINUED

System #6

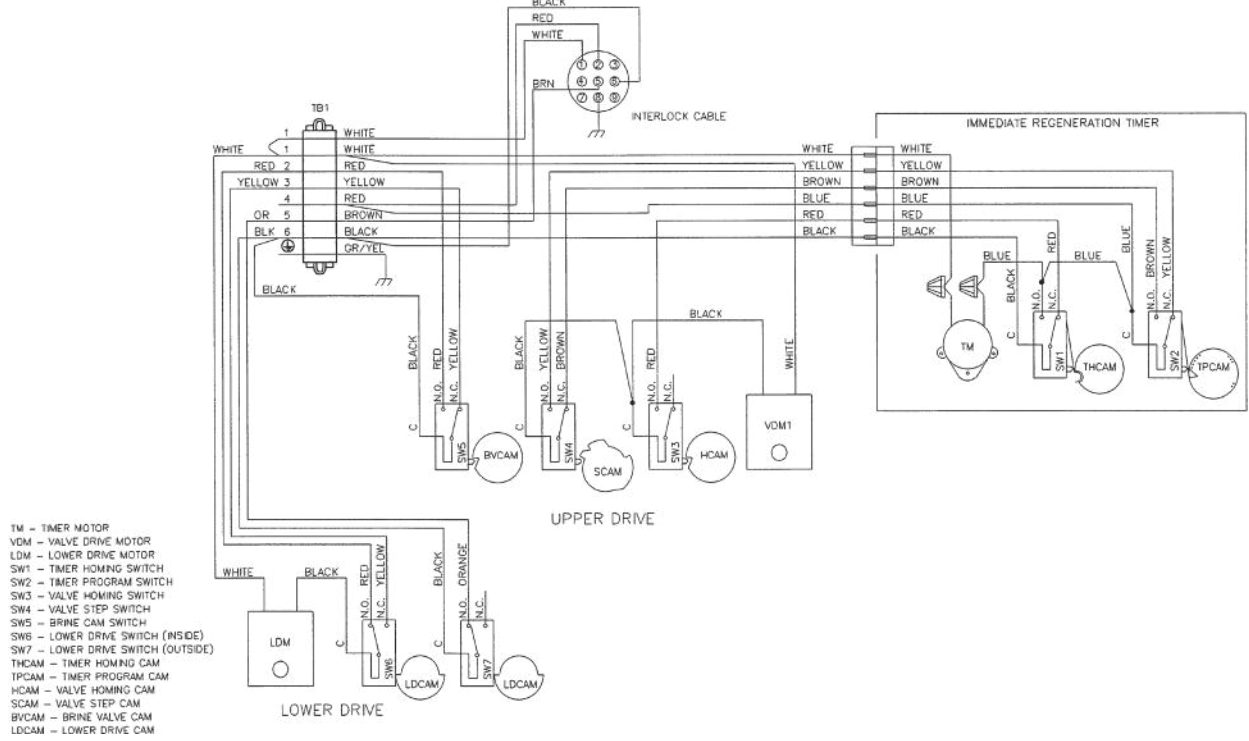
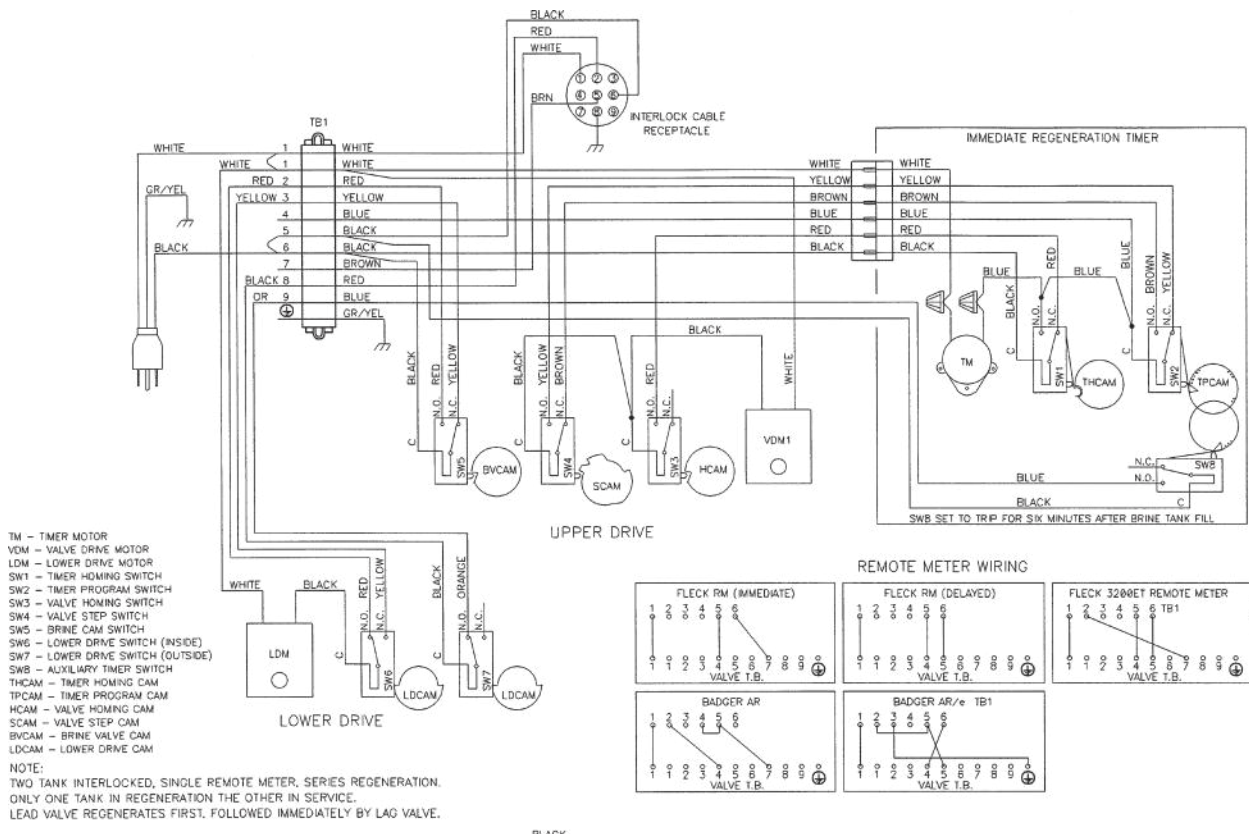

VALVE WIRING CONTINUED

System #7

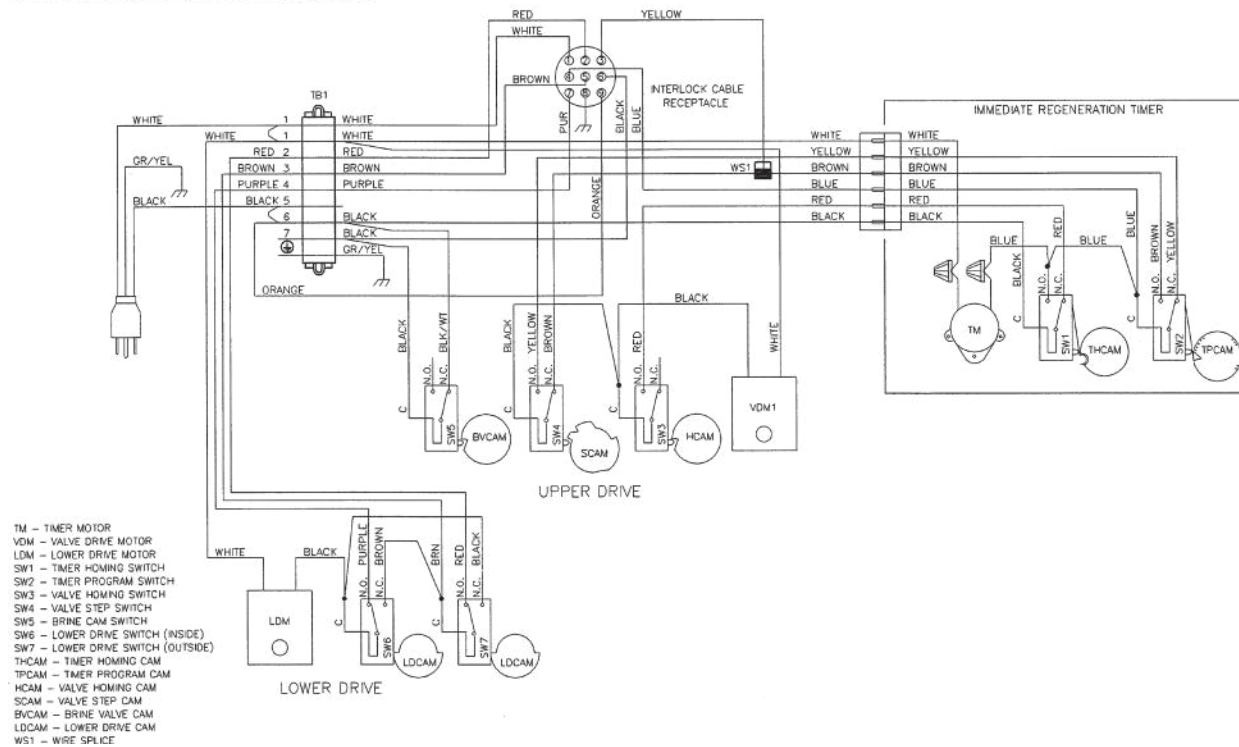
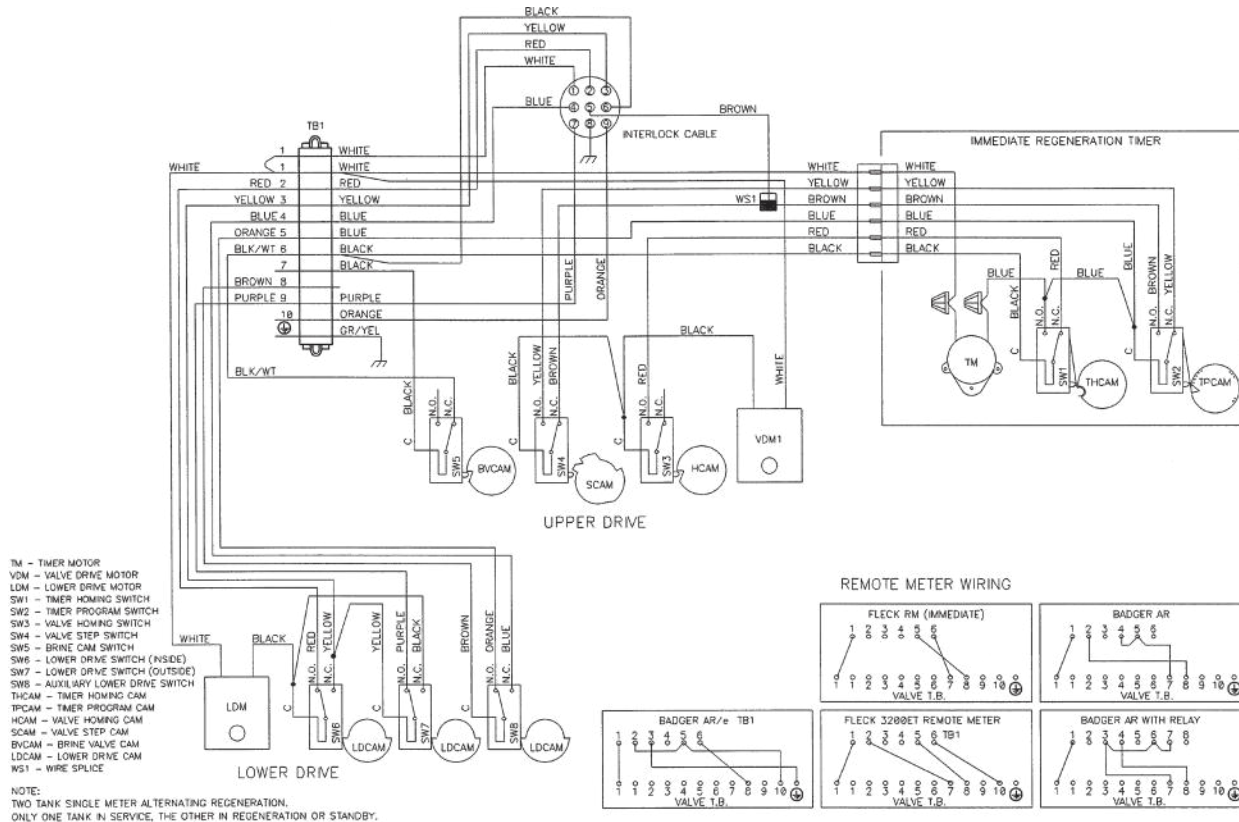

VALVE WIRING CONTINUED

System #7 Multivalve

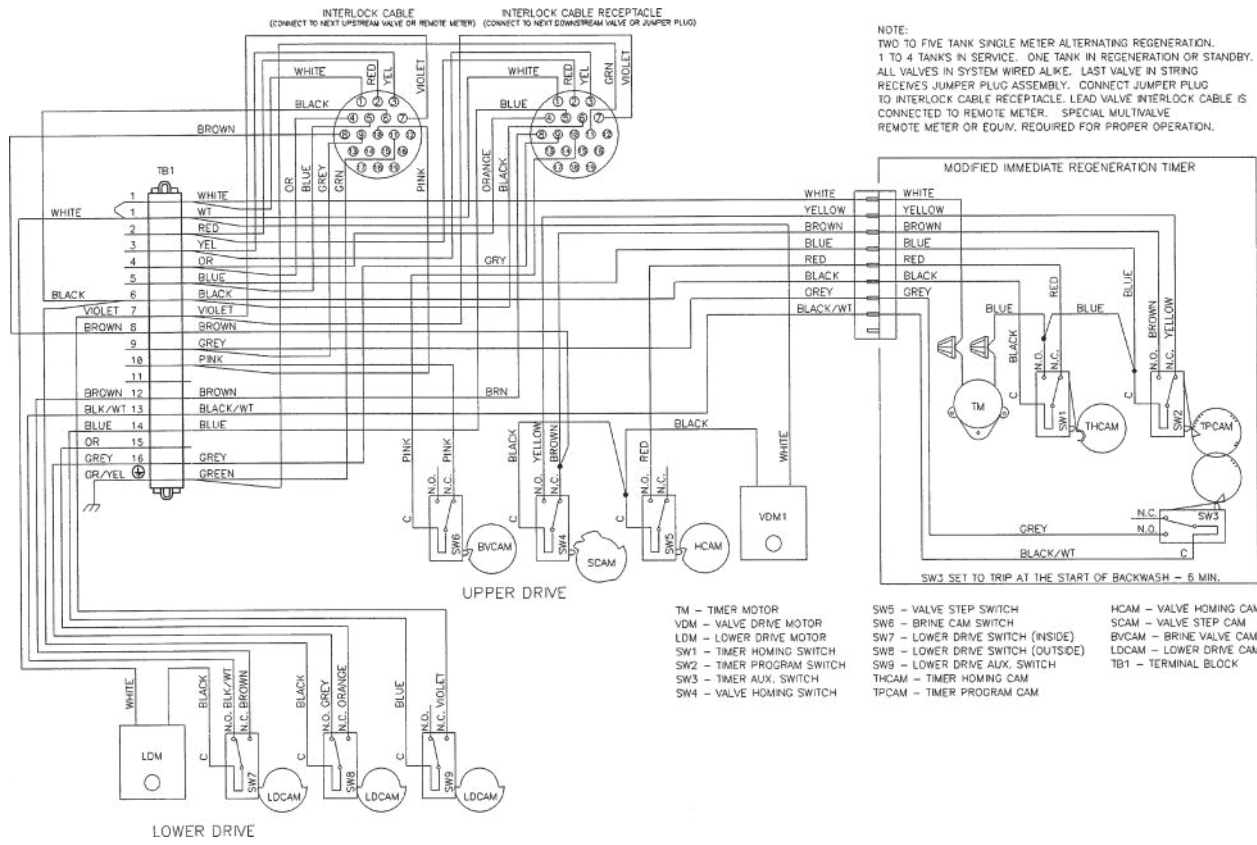

NOTE:
TWO TO FIVE TANK SINGLE METER ALTERNATING REGENERATION.
1 TO 4 TANKS IN SERVICE. ONE TANK IN REGENERATION OR STANDBY.
ALL VALVES IN SYSTEM WIRED ALIKE. LAST VALVE IN STRING
RECEIVES JUMPER PLUG ASSEMBLY. CONNECT JUMPER PLUG
TO INTERLOCK CABLE RECEPTACLE. LEAD VALVE INTERLOCK CABLE IS
CONNECTED TO REMOTE METER. SPECIAL MULTIVALVE
REMOTE METER OR EDUM. REQUIRED FOR PROPER OPERATION.

- TM - TIMER MOTOR
- VDM - VALVE DRIVE MOTOR
- LDM - LOWER DRIVE MOTOR
- SW1 - TIMER HOMING SWITCH
- SW2 - TIMER PROGRAM SWITCH
- SW3 - TIMER AUX. SWITCH
- SW4 - VALVE HOMING SWITCH
- SW5 - VALVE STEP SWITCH
- SW6 - BRINE CAM SWITCH
- SW7 - LOWER DRIVE SWITCH (INSIDE)
- SW8 - LOWER DRIVE SWITCH (OUTSIDE)
- SW9 - LOWER DRIVE AUX. SWITCH
- THCAM - TIMER HOMING CAM
- TPCAM - TIMER PROGRAM CAM
- SCAM - VALVE STEP CAM
- BVCAM - BRINE VALVE CAM
- LDCAM - LOWER DRIVE CAM
- TCAM - VALVE STEP CAM

Water Treatment System Warranty

This quality FRAKCO water softener is designed and built to provide many years of satisfactory performance under normal use. FRAKCO, INC. pledges to the original owner that for sixty months, all non-wearable items of the above-described water treatment system proven to be defective due to workmanship and/or materials will be replaced or repaired. FRAKCO also pledges that the fiberglass media tank is covered under this warranty for ten years if owned by the original purchaser. Our pledge does not apply if the damage is caused by defective installation; water pressure in excess of eighty pounds per square inch; water temperature in excess of 110° F.; misuse; unauthorized alterations; freezing; accident; fire; neglect; or damage caused by shipping.

To obtain service under this warranty, notify FRAKCO, INC in writing of any defects in workmanship within thirty days of the appearance of such defects. Such written notice must include the date of purchase, the part number, and a description of the defect. Upon receiving such notice and determining that the defect is covered by this warranty, FRAKCO, INC. will replace or repair the defective item. Replacement of a defective item will be at FRAKCO'S factory in Luverne, MN, and the purchaser must ship the defective item at its own expense to FRAKCO'S factory. Replacement items will be shipped by FRAKCO F.O.B. Luverne, Minnesota, with a shipping carton furnished. In the event certain models or colors of the replacement item are out of stock, FRAKCO, INC. may, after notifying the purchaser, furnish another model or color of the replacement item. The factory will not pay for service charges and will not perform any repair or service functions other than at its home office. Please follow the enclosed instructions and local codes in installing your water treatment system. Failure to do so will void this warranty. Nothing in the warranty may be construed as involving the factory in the relationship between Dealer and Owner.

This warranty gives the purchaser specific legal rights. The purchase may also have implied warranty rights. In the event of a problem with warranty service or performance, the purchaser may be able to go to a Small Claims Court, a State Court, or a Federal District Court. This warranty complies with the 1975 Federal Warranty Law.

Model No. _____ Serial No. _____

Date Installed _____ Dealer _____

Address _____

MANUFACTURED BY: FRAKCO, INC.
500 N BLUE MOUND AVE
LUVERNE, MINNESOTA
56156
WWW.FRAKCO.COM