



Residential Reverse Osmosis System Installation, Operation, & Maintenance Manual

Model: AM4QC

Serial Number: _____

Install Date: _____

Installed By: _____

Service Phone: _____

Sold By: _____



Please read this manual carefully before proceeding with installation. Your failure to follow any of these instructions or operating parameters, may lead to personal injury or damage to the equipment and/or personal property. Do not use this RO system with water that is microbiologically unsafe or of unknown quality, without adequate disinfection before or after the system. This RO system contains replaceable treatment components critical for effective performance. It is the user's responsibility to periodically test the product water to verify the system is performing satisfactorily. Failure to properly maintain this RO system may cause a health risk.

Save this manual for future reference

TABLE OF CONTENTS

	Page
SECTION I	INTRODUCTION.....3
SECTION II	SPECIFICATIONS4
	Installation Diagrams..... 5
SECTION III	PREPARATION8
	A. Major System Components 8
	B. Tools Recommended for Installation 8
	C. Site Selection For Major System Components 8
SECTION IV	INSTALLATION STEPS9
	A. Faucet Installation 9
	B. Feed Water Saddle Valve Installation 11
	C. Drain Clamp Installation 12
	D. Manifold Assembly Installation 12
	E. Positioning the Drinking Water Holding Tank and Make the Final Hose Connections 13
	F. Start Up..... 13
SECTION V	OPERATION AND MAINTENANCE..... 13
	A. Normal Operation 13
	B. Changing Modules 14
	C. In-line Activated Carbon Post Filter Assembly..... 15
SECTION VI	TROUBLESHOOTING GUIDE..... 16
EXPLODED VIEW AND PARTS LIST 18	

IMPORTANT NOTICES:

This drinking water system contains replaceable treatment components critical for effective performance. The end-user is responsible to periodically test the R.O. Product Water to verify that the System is performing satisfactorily. See the test kit(s) for sampling instructions.

This system is acceptable for treatment of influent concentrations of no more than 27 mg/L nitrate and 3 mg/L nitrite in combination measured as N and is certified for nitrate/nitrite reduction only for water supplies with a pressure of 280 kPa (40 psig) or greater.

DO NOT USE WITH WATER THAT IS MICROBIOLOGICALLY UNSAFE OR OF UNKNOWN QUALITY, WITHOUT ADEQUATE DISINFECTION BEFORE THE SYSTEM.

CAUTION:

All individuals should take adequate precautions when changing the filter modules, including protective gloves, to avoid direct contact with the exhausted modules.

SECTION I • INTRODUCTION

Your new Reverse Osmosis (R.O.) Drinking Water System uses a combination of filtration technologies to reduce unwanted contaminants in a water supply. The following steps combine to give you the best in clear sparkling drinking water.

MECHANICAL FILTRATION/ACTIVATED CARBON

The sediment/carbon modules are designed to reduce the larger particles such as silt, rust, and scale. Its 5 micron (equal to 0.0002 inch) nominal rating helps to give maximum life to the R.O. Membrane. The activated carbon in the modules, has been designed to reduce any chlorine that may be present in the feed water. This pretreatment is also necessary for membrane protection.

REVERSE OSMOSIS MEMBRANE

The R.O. Membrane is the heart of the filtration system. It is designed to reduce the dissolved mineral content of the water. Minerals picked up in the environment, by the water, are measured as Total Dissolved Solids (TDS). In the Reverse Osmosis process, dissolved minerals are separated from the incoming water (Feed Water) to produce the product water (Permeate). The excess minerals are rinsed to drain (Reject Water).

The membrane is a specially constructed, fully aromatic polyamide film and is classified as a Thin Film Composite (TFC). The spiral wound construction of the R.O. Membrane provides maximum surface area for water production and is less susceptible to fouling by particulate matter, turbidity, and colloidal materials.

IN-LINE ACTIVATED CARBON POST FILTER

The In-Line Activated Carbon Post Filter is located after the Holding Tank and has been designed to reduce the tastes and odors that may pass through the system. It adds a final polish to the water.

AUTOMATIC SHUTOFF VALVE

The ASO Valve senses when the Holding Tank is full and closes the feed water supply to prevent excess reject water from going to drain when the unit is not producing water.

SECTION II • SPECIFICATIONS

TABLE A – QUALIFIED SYSTEM PERFORMANCE

Because the performance of an R.O. Membrane is highly dependent upon pressure, temperature, pH and TDS, the following should be used for comparison purposes only.

	U.S.	Metric
Membrane Production ¹	41-53 gpd	155-201 lpd
Membrane TDS Reduction ¹	96% minimum	96% minimum
Drain (reject water) Flow	3-5 times product flow	3-5 times product flow
Empty Storage Tank Pre-charge	5-7 psig air	35-48kPa air

1: Industry standards measure R.O. Membranes performance with no backpressure on the product water, at 65 psig (448kPa) and 77°F (25°C). Further conditions on the above are 600 ppm TDS. Production rate and TDS reduction figures are for a new Membrane that has been rinsed for 24 hours. The production rate of a new Membrane can decrease by 10% per year or more, depending upon the scaling and fouling tendencies of the Feed Water.

TABLE B – RECOMMENDED OPERATING LIMITS FOR FEED WATER

	U.S.	Metric
Water Pressure	40 -100 psig	280 - 690 kPa
TDS	2000 ppm max.	2000 mg/l max.
Temperature	40-100°F	4-38°C
pH	4-11 (optimum rejection at pH 7.0-7.5)	
Hardness	<10 g/g or soften	<170 mg/l or soften
Iron	<0.1 ppm	<0.1 mg/l
Manganese	<0.05 ppm	<0.05 mg/l
Hydrogen Sulfide	None	None
Chlorine	Chlorine will damage a TFC Membrane. The Sediment/Carbon Module has been designed to reduce chlorine from the incoming water. Change filter every 6 to 12 months, more often if the water contains more than 1 ppm chlorine.	
Bacteria	Must be potable. DO NOT USE WITH WATER THAT IS MICROBIOLOGICALLY UNSAFE OR OF UNKNOWN QUALITY, WITHOUT ADEQUATE DISINFECTION BEFORE THE SYSTEM.	

TYPICAL UNDER-SINK INSTALLATION DIAGRAM

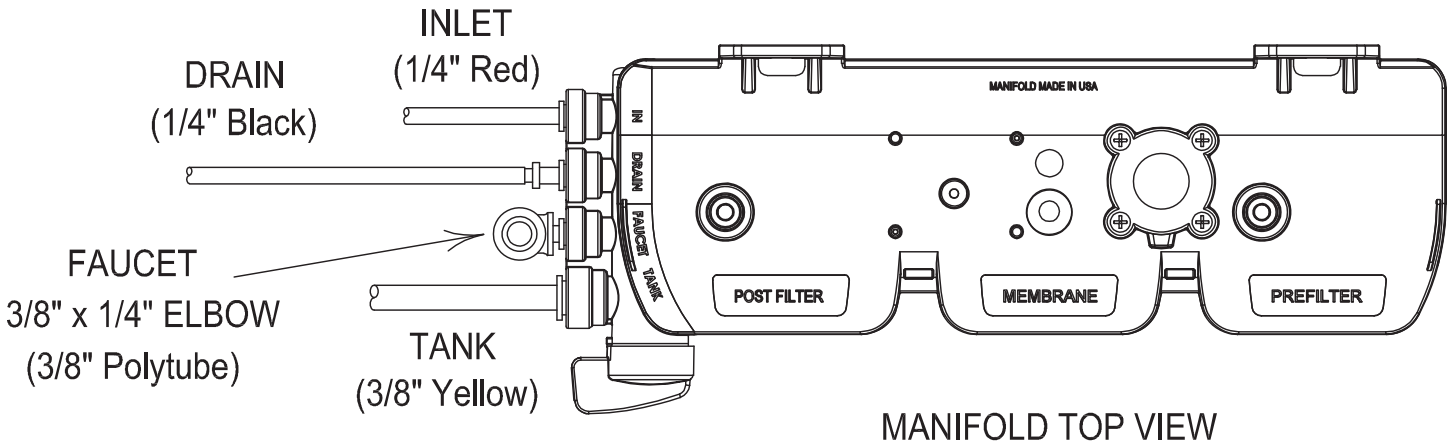
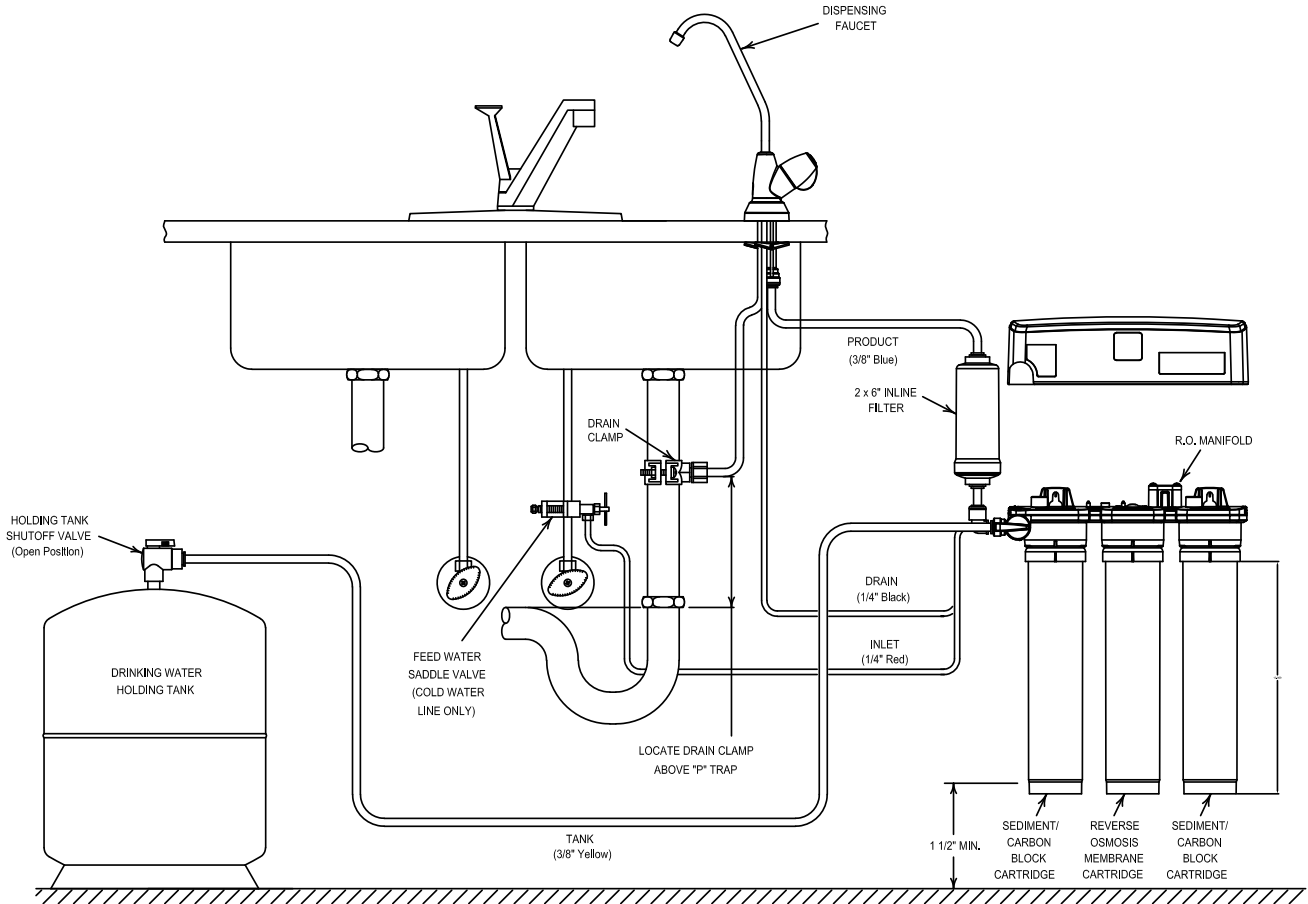

TYPICAL BASEMENT INSTALLATION DIAGRAM

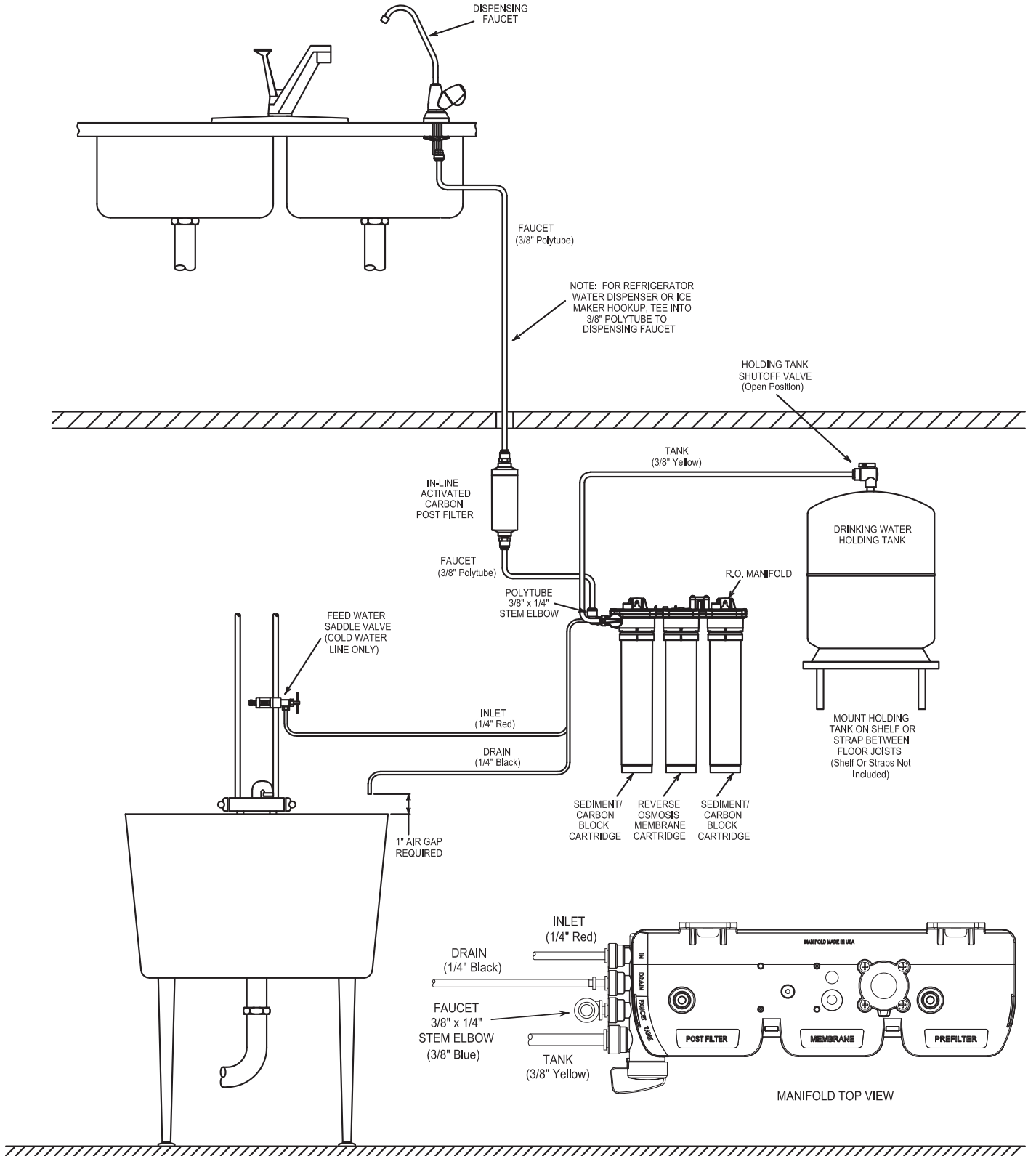

TYPICAL BASEMENT INSTALLATION AND REFRIGERATOR DIAGRAM

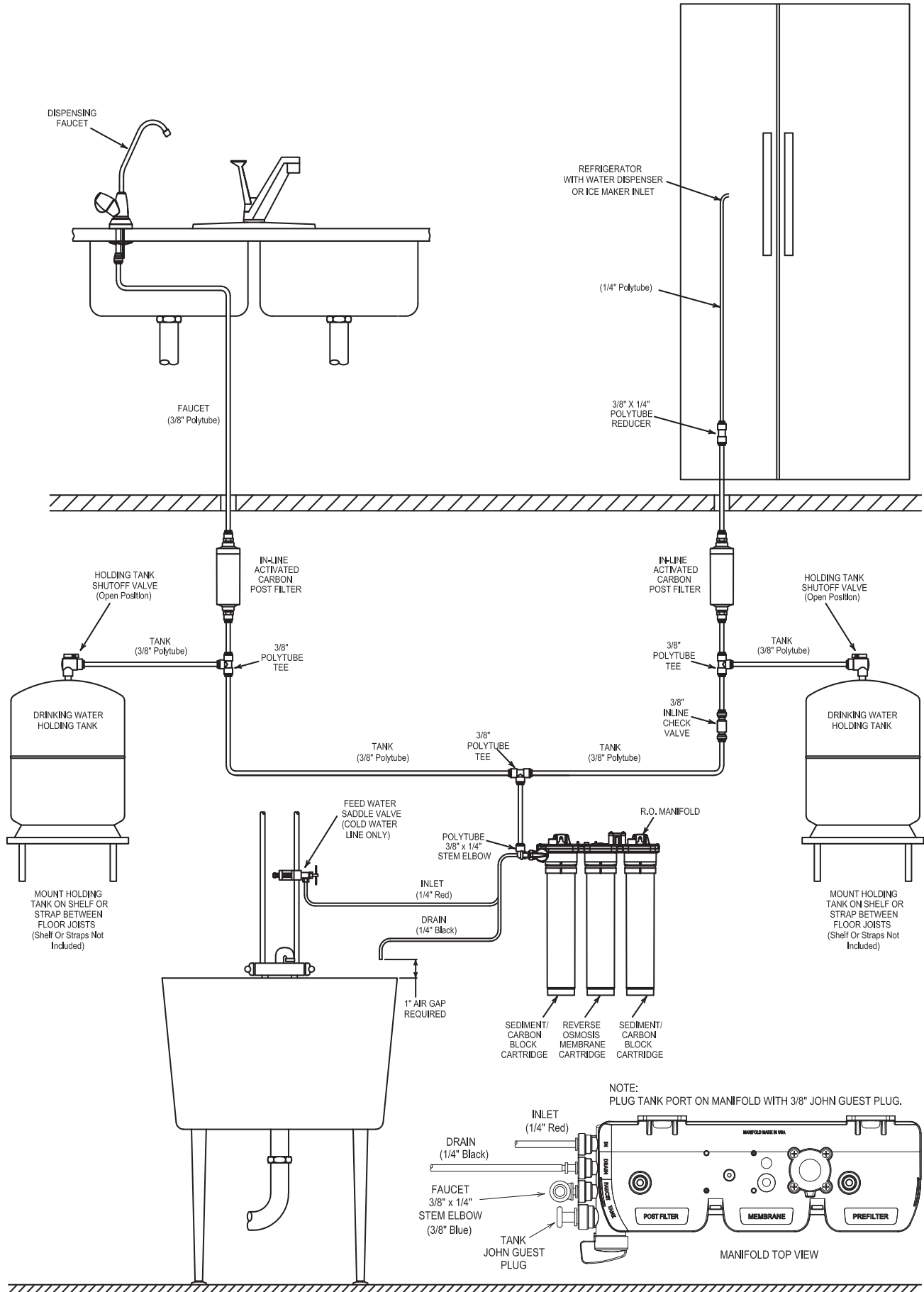

SECTION III • PREPARATION

A. Major System Components

The following components comprise the R.O. Drinking Water System.

- An R.O. Manifold assembly.
- A Drinking Water Holding Tank.
- A Dispensing Faucet.
- A Feed Water Saddle Valve.
- A Drain Clamp.
- Plastic Tubing and tube connectors.
- A Reverse Osmosis Membrane Module.
- Two Sediment/Carbon Modules.
- R.O. System Cover with or without Water Quality Monitor.*
- Other items necessary for installation may include wood screws or machine screws and nuts for mounting the manifold, or concrete anchors for hanging on basement wall. Additional tubing or tube connectors. Plastic wire ties for organizing tubing.

* The Water Quality Monitor may be necessary to conform to state or local codes, check with the local plumbing authority.

B. Tools Recommended for Installation

The following tools will cover most of the installation sites encountered:

- $\frac{3}{8}$ " variable speed electric drill.
- Extension work light with outlet.
- Safety glasses.
- $1\frac{1}{4}$ " porcelain hole cutter kit.
- $1\frac{1}{4}$ " Greenlee hole punch and $\frac{1}{8}$ " and $\frac{1}{2}$ " metal drill bits for pilot hole.
- Center punch and hammer.
- $1\frac{1}{4}$ " wood bit.
- Concrete drill bits.
- Assorted wood and metal drill bits including $\frac{7}{32}$ " metal drill bit.
- Phillips head and flat blade screwdrivers.
- $\frac{1}{2}$ ", $\frac{9}{16}$ " and $\frac{5}{8}$ " open end wrenches.
- Teflon tape.
- Wide masking tape or duct tape.
- Plastic tubing cutter.
- Extra plastic tubing.
- Low range air pressure gauge.
- Bicycle hand air pump or compressor.
- Small bottle of liquid chlorine bleach.
- Graduated measuring cylinder.
- Paper towels, whisk broom and assorted clean up materials.

C. Site Selection for Major System Components

The R.O. System is designed to fit under a sink, however, because of space limitations or other reasons, the system's flexible design allows for installation in other locations. When determining the location, remember that access to a cold water tap line, the household drain, and ease of filter replacement are important considerations. All components and tubing should be located in an area which is not exposed to freezing temperatures. If winter temperatures are severe, the area should be above the minimum temperature listed in Table B for proper performance. Do not expose unit or tubing to direct sunlight.

1. Dispensing Faucet

The faucet should be placed near the sink where drinking water is normally obtained. Convenience of use (filling of water pitchers and glasses), and an open area beneath the faucet under the sink for attaching product and drain tubing are considerations. A 2" diameter flat surface is required above and below the installation site. The thickness of the mounting surface should not exceed $1\frac{1}{4}$ ". Watch for strengthening webbing on the underside of cast iron sinks.

2. Drinking Water Holding Tank

The Holding Tank may be placed where it is convenient within 10 feet of the faucet; under the sink or in an adjacent cabinet are the best choices. If a longer run of tubing is required, the tubing should be the $\frac{3}{8}$ " diameter OD size to prevent a high pressure drop. Remember, these tanks can weigh up to 30 pounds when full of water; a firm, level area is required.

3. R.O. Manifold Assembly

The manifold can be installed on either the right or left side of the under-sink area or a cabinet. The right side is recommended because all the tubing will be to the back of the cabinet and out of the way. Installation in the basement is also an option. Another location is near the laundry/utility sink where cold potable water and drain access is handy. The mounting location should allow adequate clearance and accessibility for module changes.

4. Feed Water Connection

The Feed Water Saddle Valve should be located as close to the manifold assembly as possible. USE A POTABLE COLD WATER SUPPLY ONLY. Softened water is preferred as it will extend the life of the R.O. Membrane.

5. Drain Connection

The wastewater must go to drain through an anti-siphon air gap. The air gap is provided in the base of the faucet. If discharging into a utility sink or standpipe, an air gap of greater than 1" above the flood rim must be provided. Do NOT connect the system drain line to the dishwasher drain or near the garbage disposal. Backpressure from these units may cause the air gap to overflow.

SECTION IV • INSTALLATION STEPS

All plumbing should be done in accordance with state and local plumbing codes.

NOTE: Some codes may require installation by a licensed plumber; check with the local plumbing authority prior to installation.

In restricted under-sink areas, it may be easier to install the faucet first. Allow adequate tubing lengths for any final component position.

A. Faucet Installation

The faucet contains an anti-siphon air gap. While the system is producing water, the drain water flows from the R.O., through the air gap and then to the household drain. The purpose of the air gap is to prevent water in the drain from backing up into the R.O. Drinking Water System.

The easiest installation is to use an existing spray attachment hole. If the spray faucet hole is not available, then the sink top must be drilled.

1. Mark the location of the center of the faucet base

2a. Drilling a stainless-steel sink:

- Center punch the hole to provide a starting point for the drill.
- Start with a smaller drill as a pilot, and then drill a $\frac{1}{2}$ " diameter hole to accept the bolt of a $1\frac{1}{4}$ " Greenlee Hole Punch ($1\frac{1}{4}$ " chassis punch).
- Clean away any chips.
- Install the punch and tighten the nut to cut the hole.
- Deburr any sharp edges.

2b. Drilling a porcelain sink:

It is best to use a special $1\frac{1}{4}$ " diameter cutter designed for porcelain. A carbide tipped masonry bit is a second choice.

- Place a piece of tape over the area to be drilled to help prevent chipping.
- Drill a pilot hole for the porcelain cutter. Use the pilot drill supplied with the kit or a carbide tipped drill.
- When drilling the $1\frac{1}{4}$ " hole, drill slowly and carefully; the porcelain chips easily.
- After drilling, clean the area well. Iron filings, if left in place, can cause rust stains.

2c. Drilling a countertop:

NOTE: The countertop must be less than $1\frac{1}{4}$ " thick. Treat ceramic tile as porcelain until the tile is penetrated, then use the carbide tipped metal cutter. Formica counter tops may be drilled with a good $1\frac{1}{4}$ " wood bit; drilling a $\frac{3}{32}$ " pilot hole will help keep the bit going straight.

3. Assemble the 1/8" Screws & Toggle Wings into the Faucet Base. Adjust the Wings approximately 1" plus the thickness of the mounting surface away from the bottom of the Faucet Base.

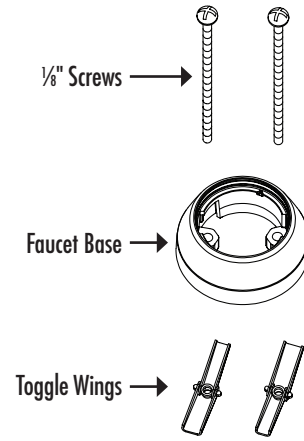

4. Place the Base Assembly through the mounting hole on the sink or countertop. Place a piece of 3/4" PVC pipe (not supplied) into the Faucet Base opening. This will separate and orient the Toggle Wings. Position the Faucet Base so that the arrows are pointing in the direction that the faucet handle will face. Tighten the 1/8" Screws with a Phillips screwdriver. When the Toggle Wings contact the mounting surface, adjust the Faucet Base to the exact desired position. Tighten the 1/8" Screws an additional 2-3 turns while holding the Faucet Base in place.

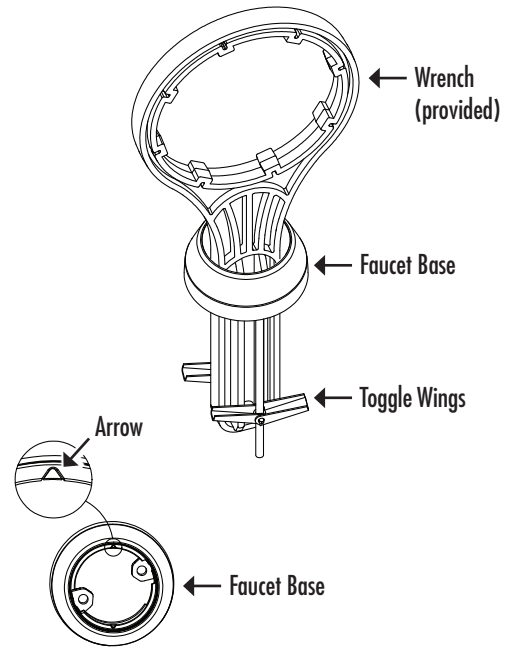

5. Connect the tubing to the Faucet. Push the Blue 3/8" Polytube into the 3/8" Quick Connect Fitting. Push the Black 3/8" Polytube onto the large Hose Barb. Push the Black 1/4" Polytube onto the small Hose Barb.

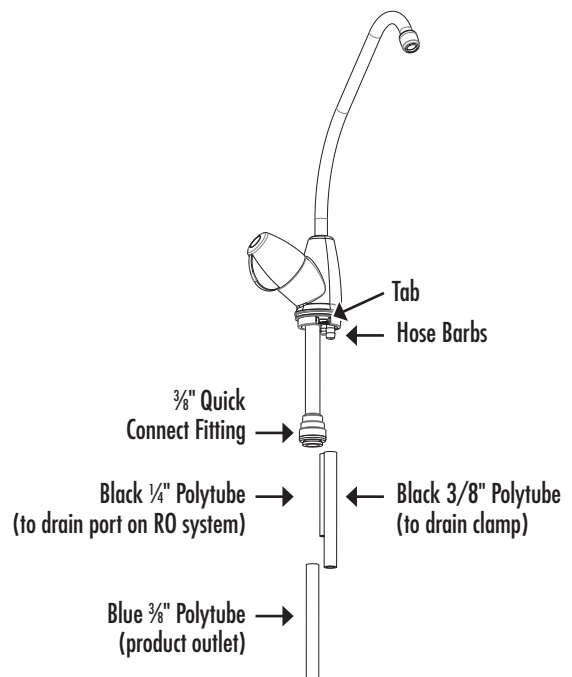

6. Determine which direction the handle should face (right or left). As shown, it can be mounted in two directions. With the handle facing the chosen direction, slide the fastened Polytubes through the Faucet Base and slide the Faucet Assembly into the Faucet Base, lining up the tabs on the Faucet with the slots on the Base. The Faucet Assembly may have to rotate slightly to get the tabs into the slots. When aligned, apply firm downward pressure to get the Faucet to fully seat. After the Faucet Assembly is seated, lock it into place by rotating it clockwise about 30 degrees.

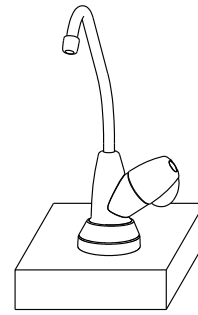

Handle to the right side

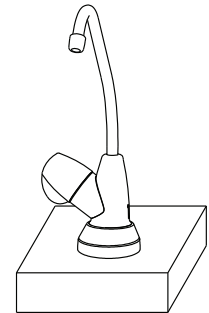

Handle to the left side

B. Feed Water Saddle Valve Installation

Decide on location. Do NOT connect to a hot water feed line. If you are not sure of the supply, run the hot water and feel the supply piping. Water over 100°F may cause permanent damage to the R.O. Membrane.

1. Shut off the water supply and drain the line.

2a. To install on (soft) Copper Tubing supply line:

- Turn the Handle of the Feed Water Saddle Valve counterclockwise (outward) until the lance does not protrude from the gasket. It may have to be pushed in.
- Assemble the Feed Water Saddle Valve on the tubing.
 - for $\frac{3}{8}$ " OD tubing use the back plate side with the small groove to prevent distortion of the tubing.
 - for larger tubing (up to $\frac{1}{2}$ " OD) use the large groove of the back plate.
- Assemble and tighten the brass screw.
- To pierce the tubing, turn the Valve Handle fully clockwise (inward). A small amount of water may escape from the outlet until it is fully pierced.
- When you feel the Valve Handle firmly seated in the clockwise direction, the copper tube is pierced, and the valve is closed.

2b. To install on (hard) steel or brass tubing supply line.

- The supply line should now be drained. Use a battery powered or properly grounded drill to avoid shock hazard.
- Drill a $\frac{3}{16}$ " hole in the supply line; (do not drill through the opposite wall).
- Turn the handle to expose the lance no more than $\frac{3}{16}$ " beyond the rubber gasket.
- Place the body of the valve over the hole so that the lance fits into the hole.
- Assemble and tighten the brass screw.
- Turn the Valve Handle clockwise (inward) until firmly seated. The valve is closed.

3. With the Feed Water Saddle Valve closed, open the sink faucet and the water supply and allow the water to run for a few minutes to flush any debris caused by the installation.

- Close the faucet and check the Feed Water Saddle Valve for leaks.

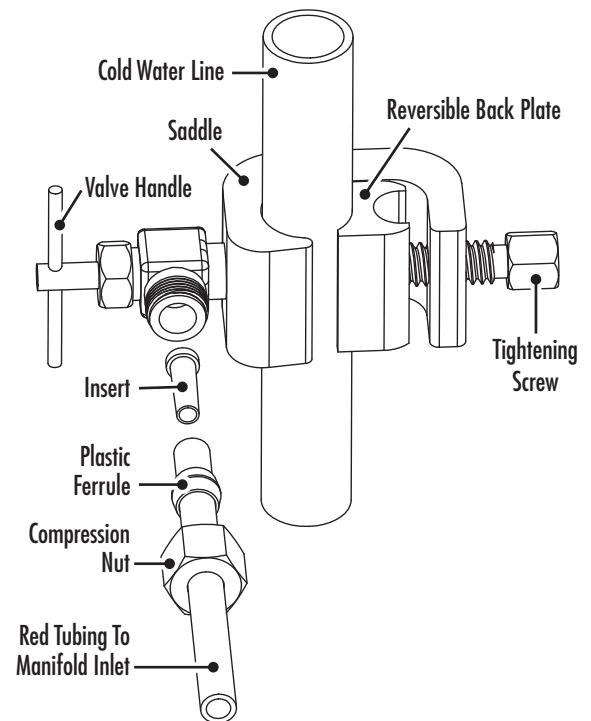

C. Drain Clamp Installation

Choose the drain outlet location per Sec. III, C.5. The following are instructions for discharging into the sink drainpipe.

1. Position the Drain Clamp on the sink drainpipe above the drain trap. Allow room for drilling. Tighten securely.
2. Use a battery powered or properly grounded drill. Using the Clamp port as a drill guide, drill a $\frac{7}{32}$ " hole through the wall of the drainpipe. Do NOT penetrate the opposite side of the pipe.
3. Locate the $\frac{3}{8}$ " Black Drain Tubing connected to the Dispensing Faucet. Route the tubing to the Drain Clamp and trim to length.
NOTE: When cutting the polytube make clean, square cuts. Failing to do so could result in poor connections and possible leaks.
CAUTION: The lowest point of the line should be the point of connection to the Drain Clamp. There should be no sag in the line as this may cause excessive noise as the reject water is flowing to drain.

- Insert the tubing into the Drain Clamp. Make sure the tubing is pressed all the way in to create a pressure-tight connection.
NOTE: If you want to pull the tubing out for some reason, push the ring around the tubing in and pull the tubing out.

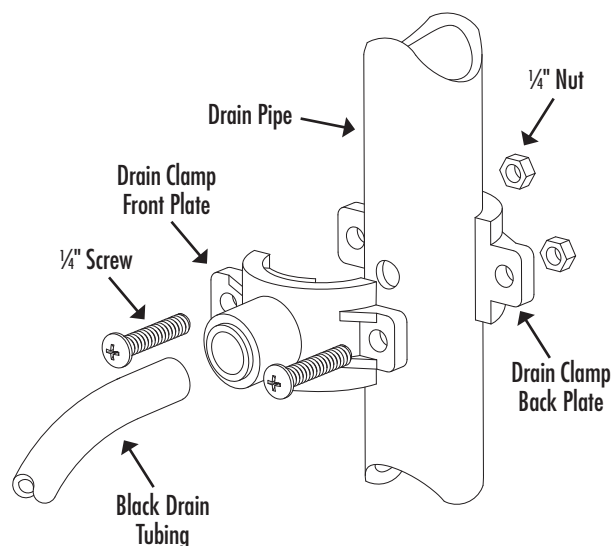

D. Manifold Assembly Instructions

Locate the site per Sec. III, C.3. Various installation sites will require different types of mounting fasteners; be sure the fastener selected will provide a firm, solid mounting. A support panel may be necessary on thin cabinet walls or to span between wall studs on particleboard or drywall.

Do not drill through exterior cabinet walls or leave sharp wood screw points exposed in readily accessible cabinet interiors. The proximity of a dishwasher or a trash compactor may require special fabrication of a mounting plate.

1. The mounting bracket will accept either #10 or #12 (5mm) mounting screws spaced on $7\frac{1}{8}$ " (18.1 cm) centers. Allow at least 2" (5.08 cm) of clearance beneath the filter housings to accommodate filter changes. Mark the two locations (the bracket can be used as a template). Install the screws and tighten them until the heads are about $\frac{5}{8}$ " from the wall.
2. Locate the $\frac{1}{4}$ " Red Feed Water Tubing. Remove the red plug from the fitting labeled "In" on the manifold and insert the tubing. Reference the special supplement sheet in the carton for proper connection of all tubing and removal of plugs. Run the tubing along its course to the Feed Water Saddle Valve, trim to length. To the end of the red polytube install the Compression Nut, the Plastic Ferrule, and the Insert. Connect to the Feed Water Saddle Valve.
3. Locate the $\frac{1}{4}$ " Black Drain Tubing connected to the Dispensing Faucet. The end of the Black Drain Tubing that should be inserted into the "Drain" port on the manifold will have a **drain restrictor** in it. Remove the black plug from the fitting labeled "Drain" on the manifold and insert the tubing. Allow the tubing to relax, then press firmly again to insure proper seating.
4. Locate the $\frac{3}{8}$ " yellow tubing, remove the yellow plug from the fitting labeled "Tank" on the manifold and insert the tubing.
5. Locate the $\frac{3}{8}$ " Blue Product Water Tubing connected to the Dispensing Faucet. Firmly press one end into the elbow labeled "faucet". The fittings will grab the tubing and seal it in place. Make sure the tubing is pressed all the way in to create a pressure tight connection.
NOTE: If the tubing is to be removed from the fitting for some reason, push the ring around the tubing in and pull the tubing out.
6. Hang the Manifold Assembly on the mounting screws and tighten. DO NOT OVERTIGHTEN.

E. Position the Drinking Water Holding Tank and Make the Final Hose Connections

1. Check the tank precharge pressure. **Make sure it is between 5 to 7 psig.** If not, use a bicycle hand pump or other pump to bring the pressure up to the 5 to 7 psig range.
2. Pull the cap/plug off the top of the tank where the Tank Shut-Off should go.
3. Wrap Teflon tape three times around the ¼" male outlet thread. Wrap in the direction of the threads (clockwise when looking down on the Holding Tank). The tape will act as a thread sealant. Screw on the Holding Tank Shut-Off Valve.
4. Locate the ⅜" Yellow Tubing. Firmly press one end into the Holding Tank Shut-Off Valve. The fittings will grab the tubing and seal it in place. Make sure the tubing is pressed all the way in to create a pressure tight connection.

F. Start Up

1. Installing the pre filter, post filter, membrane module and sanitizing the holding tank.
 - Remove the plugs on the underside of the manifold labeled "SEDIMENT/CARBON". Unwrap the Sediment/Carbon Modules (2), make certain the module has an O-ring on its stem and within the O-ring groove of the housing. With the alignment notch facing manifold shut off (left), press module firmly into the manifold, tighten the modules ¼ turn to the right by hand and turn into its locked position.
 - Remove the plug labeled "Membrane" from the underside of the manifold. Unwrap the Membrane Module, make certain the module has O-ring on its stem and within the O-ring groove of the housing. With the alignment notch facing manifold shut off (left) press module firmly into the manifold, tighten the modules ¼ turn to the right by hand and turn into its locked position.
 - Disconnect the yellow product water tubing that runs from the Holding Tank to the Manifold (see plate top view, page 5). Put 50 drops of bleach (this is ½ tsp. or 3 ml) into the tubing and reconnect to the manifold plate.
2. Start rinsing the system:
 - Slowly open the Feed Water Saddle Valve counterclockwise to its fully open position.
 - Open the faucet to allow air to escape while system is filling the housings and tubing.
 - Check the Air Gap Window on the Dispensing Faucet to be sure that the drain water is flowing.
 - R.O. should be filling and purging air, when water starts dripping consistently from faucet spout, close faucet handle.
 - **Do not re-open the Faucet for at least 3 to 4 hours, or when auto shutoff valve closes (no water to drain)**
 - **Do not use the first three full tanks of water, open faucet to drain tank empty.**

SECTION V • OPERATION & MAINTENANCE

A. Normal Operation

1. It is normal for the Total Dissolved Solids (TDS) in the water to be higher than normal during the first 3 to 5 gallons of operation; this is due to the sanitizing solution and the new Post Filters. After this water is rinsed to drain, the removal rate should stabilize at a value of greater than 75%. Water pressure, temperature and high TDS affects the production rate and quality.

2. R.O. systems produce drinking water at relatively slow rates; it can take up to 3 to 5 hours or more to fill the Holding Tank. Normal operation is to let the Holding Tank fill with water and then draw water as needed. When the pressure in the Holding Tank falls to a given pressure (as the water is being used) the Automatic Shut-Off Valve (ASO Valve) will start water production and the system will refill the Holding Tank. When the Holding Tank is full and no water is being used, the ASO Valve will automatically shut off the feed water to conserve water. The more water that is used (up to the capacity of the system) the better the R.O. system will function. Other uses for the water are flowers, pets and rinsing glassware.

With each use it is recommended that you run the faucet for at least 3 seconds prior to using water, this is especially important if the system has not been used daily. After periods of non-use, such as a week of vacation or longer, it is better to empty the Holding Tank and allow the system to produce fresh water for use.

B. Changing Modules

THIS R.O. SYSTEM CONTAINS MODULES WHICH MUST BE REPLACED AT REGULAR INTERVALS TO MAINTAIN PROPER PERFORMANCE. USE ONLY FACTORY APPROVED MODULES.

For replacement modules contact the local dealer who installed your system or contact the distributor to find the nearest dealer.

All individuals should take adequate precautions when changing the filters, including wearing protective gloves, to maintain a sanitary environment handling and changing modules.

The recommended interval for changing the Pre and Post Filter modules is every 6 to 12 months depending on the raw water quality (not the R.O. Membrane). Typical TFC Membrane life expectancy is three years average. Local conditions may dictate more frequent changes.

NOTE: If the R.O. Membrane is to be replaced, see Sec. IV, F.1- 2 for the proper procedure. When changing membrane treat as if it is a new install, membranes have a preservative in them.

Use a drip pan to catch any water that may spill when the Filter Modules are removed. Refer to installation views on page 5 for proper locations.

1. Close the Manifold shut off valve by turning $\frac{1}{4}$ turn clockwise and open the dispensing Faucet. This will allow the manifold to be de-pressurized so you can safely remove the old modules.
2. Loosen and remove the Sediment/Carbon Pre and Carbon Post Filter Modules (2). Press upward and to the left $\frac{1}{4}$ turn to release module from its locked position. Properly discard the old/used modules.
 - Unwrap the new Pre-Sediment/Carbon Modules, remove dust cover from top.
 - Check the Module O-rings for proper position on its stem and in its housing groove. With the alignment notch facing manifold shut off (left) press module firmly into the manifold, tighten the modules $\frac{1}{4}$ turn to the right by hand and turn into its locked position.
 - Unwrap the new Post Sediment/Carbon Modules, remove dust cover from top.
 - Check the Module O-rings for proper position on its stem and in its housing groove. With the alignment notch facing manifold shut off (left) press module firmly into the manifold, tighten the modules $\frac{1}{4}$ turn to the right by hand and turn into its locked position.
 - Open the manifold shut off valve by turning handle $\frac{1}{4}$ turn counterclockwise to its fully open position.
 - With dispensing faucet open allow water to run to the drain, this will allow the air to purge from your new modules. This also will rinse the new modules before returning the system to your normal use.
 - Discard the first full tank of water produced; then system will be ready to use.

C. In-line Activated Carbon Post Filter Assembly

Changing the In-Line Activated Carbon Post Filter:

1. Close the Feed Water Saddle Valve by turning fully clockwise.
2. Close the Holding Tank Valve and then open the Dispensing Faucet to release the pressure.
3. Remove the In-Line Activated Carbon Post Filter. Disconnect the used Post Filter by pressing in the connector's collar and at the same time pulling the tube out of the fitting.
4. Firmly reconnect the polytubes to the new Post Filter. (Refer to Fig. 5). Make sure the tubing is pressed all the way in to create a pressure tight connection.

NOTE: If you want to pull the tubing out for some reason, push the ring around the tubing in and pull the tubing out.

5. Slowly open the Feed Water Saddle Valve.
6. When water begins dripping out of the Faucet, in the following order, close the Faucet and open the Holding Tank Valve. When the Faucet is first opened, expect air and carbon fines (very fine black powder), from the new Post Filter to be rinsed out. This is normal for the first tank of water.

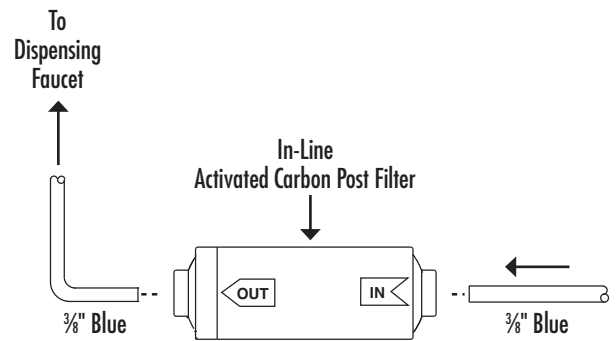

SECTION VI • TROUBLESHOOTING GUIDE

Problem	Possible Cause	Solution
Low quantity of Product Water from Holding Tank	Feed Water Valve is plugged or closed	Open or unplug valve
	Clogged Sediment Module(s)	Replace module(s)
	Low water pressure	Feed Water pressure must be above 40 psig
	R.O. Membrane is fouled	Correct cause of fouling and replace R.O. Membrane
	Air precharge pressure in Holding Tank is too high or too low	Empty water from Holding Tank, and with the faucet open, adjust air pressure to 5–7 psig (35–48 kPa) range
	Air bladder in the Holding Tank is ruptured	Replace Tank
	Holding Tank Valve is closed	Open Valve
	No drain flow, the Drain Restrictor is plugged	Clear or replace Drain Restrictor
	No drain flow, the drain orifice in the Dispensing Faucet is plugged	Clear or replace the Dispensing Faucet
	The Check Valve is stuck	Free Check Valve
	The ASO Valve is malfunctioning	Replace ASO Valve components
Low pressure at the Dispensing Faucet	In-Line Activated Carbon Post Filter is plugged	Replace Post Filter
	Air precharge in the Holding Tank is too low	Empty water from Holding Tank and with the faucet open, adjust the air pressure to 5–7 psig (35–48 kPa) range
	Holding Tank Valve is partially closed	Open Valve
	The Dispensing Faucet is out of adjustment or faulty	Repair or replace Dispensing Faucet
	Heavy water use, Holding Tank is depleted	Allow Holding Tank to refill (adding a second Holding Tank will increase storage capacity)
	Low Water Production	See Low Quantity of Product Water from Holding Tank section above
High Total Dissolved Solids (TDS) in the Product Water	Clogged Sediment Module(s)	Replace Module(s)
	Low Water Pressure	If Membrane life is unusually short, find and correct the problem; replace membrane
	Membrane O–ring is crimped	Check O–ring
	The Product Water and Drain Water lines are reversed	Correct plumbing
	No drain flow, Drain Restrictor is clogged	Clear or replace Drain Restrictor
	No drain flow, the drain orifice in the Dispensing Faucet is plugged	Clear or replace Dispensing Faucet
	The ASO Valve is not closing	Repair or replace the ASO Valve Components
	New In-Line Activated Carbon Post Filter not rinsed completely	Flush with several full tanks of Product Water
	The Feed Water TDS has increased	An increase in Feed Water TDS will give a corresponding increase in Product Water TDS

Problem	Possible Cause	Solution
Tastes and odors in the Product Water	The In-Line or Activated Carbon Post Filter is exhausted	Replace Filters
	There is foreign matter in the Holding Tank	Clean, flush and sanitize the system. Replace the filters
	The Product Water and Drain Water lines are reversed	Correct plumbing
	Dissolved gases in the Feed Water	Pretreat Feed Water to remove dissolved gasses
	Increase in Product Water TDS	See high TDS in the Product Water section.
Drain Water overflows at the Dispensing Faucet	Air Gap is blocked	Clear Air Gap; Rinse with vinegar for removal of calcium buildup
	Drain tubing is clogged	Clear tubing
	Drain Clamp hole is misaligned	Align with hole in the drainpipe
	Excessive drain flow rate	Replace Drain Restrictor
Faucet leaks or drips	Leaks from base of the delivery tube	O-ring is bad, replace O-ring
Fitting leaks in general	Close the Feed Water Valve and relieve pressure within the system before disconnecting any tubing or replacing fittings. Before replacing a fitting, re-cut the tubing and re-insert into the fitting to see if that solves the leak. If pipe threads are leaking, remove and retape with Teflon tape.	

EXPLODED VIEW

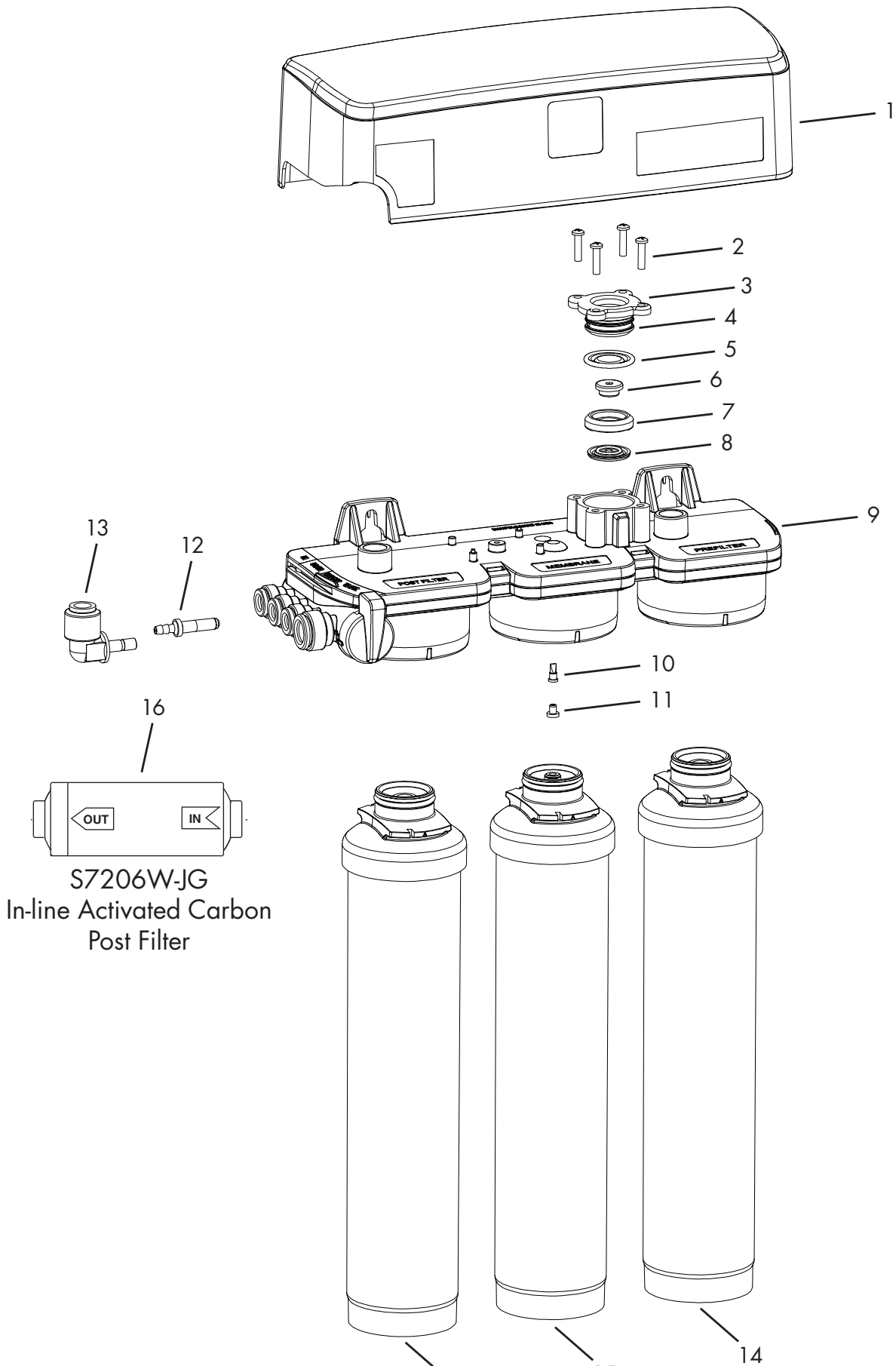

PARTS LIST

Drawing Number	Part Number	Description	Quantity
1	S3504-01	Cover Top Load White QC RO/CS	1
2	S2009	Self Tapping Screws	4
3	S2005-01	ASO Cap for QC/CS	1
4	S2013	ASO Cap O-ring	1
5	S2011	ASO Diaphragm Large	1
6	S2007-01	ASO Piston QC/CS	1
7	S2006-01	ASO Piston Ring QC/CS	1
8	S2010	ASO Diaphragm Small	1
9	S3842-01	Manifold 4-Stage	1
10	S1276	Check Valve	1
11	S1277	Check Valve Retainer	1
12	S2116-6	Drain Restrictor 60 gpd/227 lpd	1
13	PK-A6TEU4-MG	Elbow ¼ Stem x ⅜ QC	1
14	S3551A-01	Sediment/Carbon CS Module	2
15	S35715A-01	Membrane 50GPD Module	1
16	S7206W-JG	In-line Activated Carbon Post Filter	1

Other components as shown on Page 5:

Part Number	Description	Quantity
C2000F	FRO-122 Tank White	1
JGPPSV501222W	JG Tank Shutoff Valve	1
R7100-CR	Chrome Faucet with Air Gap	1
S1117-01	Drain Clamp Assembly ⅜"	1
S1118-01	Self-Piercing Feed Water Saddle Valve	1

Parts included but not shown:

Part Number	Description	Quantity
S1405	Wrench for Collets	1
S1447	Nitrate/Nitrite Test Kits – 6 tests	1

R.O. DRINKING WATER SYSTEM FIVE/ONE YEAR LIMITED WARRANTY

Frakco, Inc. warrants its R.O. Drinking Water System to be free from defects in materials and workmanship for a period of five years from the date of purchase when installed and operated within recommended parameters.

Frakco, Inc. will repair or replace at its discretion any defective component. This warranty does not cover the disposable sediment and carbon filters whose service life depends on feed water conditions. The reverse osmosis membrane is warranted for one year. If the required prefilter conditions to the membrane are not followed the membrane will not be warranted.

CONDITIONS OF WARRANTY

The above warranty shall not apply to any part of the Aqua Magic Mini R.O. Drinking Water System that is damaged because of occurrences including but not limited to neglect, misuse, alteration, accident, misapplication, physical damage, or damage caused by fire, acts of God, freezing or hot water.

All replacement filters and membranes must be Aqua Magic Mini filters and membranes or the warranty is void. If the unit is altered by anyone other than Frakco, Inc. the warranty is void.

To obtain warranty service: (A) contact your local dealer who supplied the unit, or (B) contact the factory for the dealer nearest you. It is the obligation of the owner to pay for shipping or travel charges to return the defective part.

This is the sole warranty made by Frakco, Inc. with respect to the R.O. Drinking Water System. No other warranties, expressed or implied, are given including merchantability or fitness for a particular purpose, incidental or consequential damages, or other losses.

This exclusion applies to the extent exclusion is permitted by the law.

No person or representative is authorized to assume for Aqua Magic Mini any liability on its behalf, or in its name, except to refer the purchaser to this warranty.

This warranty gives you specific legal rights, you may also have other rights which vary from state to state.

Frakco, Inc.
500 N Blue Mound Ave
Luverne, MN 56156
www.frakco.com