

**Reo-Pure**™ water purification systems

**LP3** SERIES  
reverse osmosis systems

# LP3-WMS 500 USER MANUAL

## Installation, Operation & Maintenance

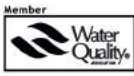
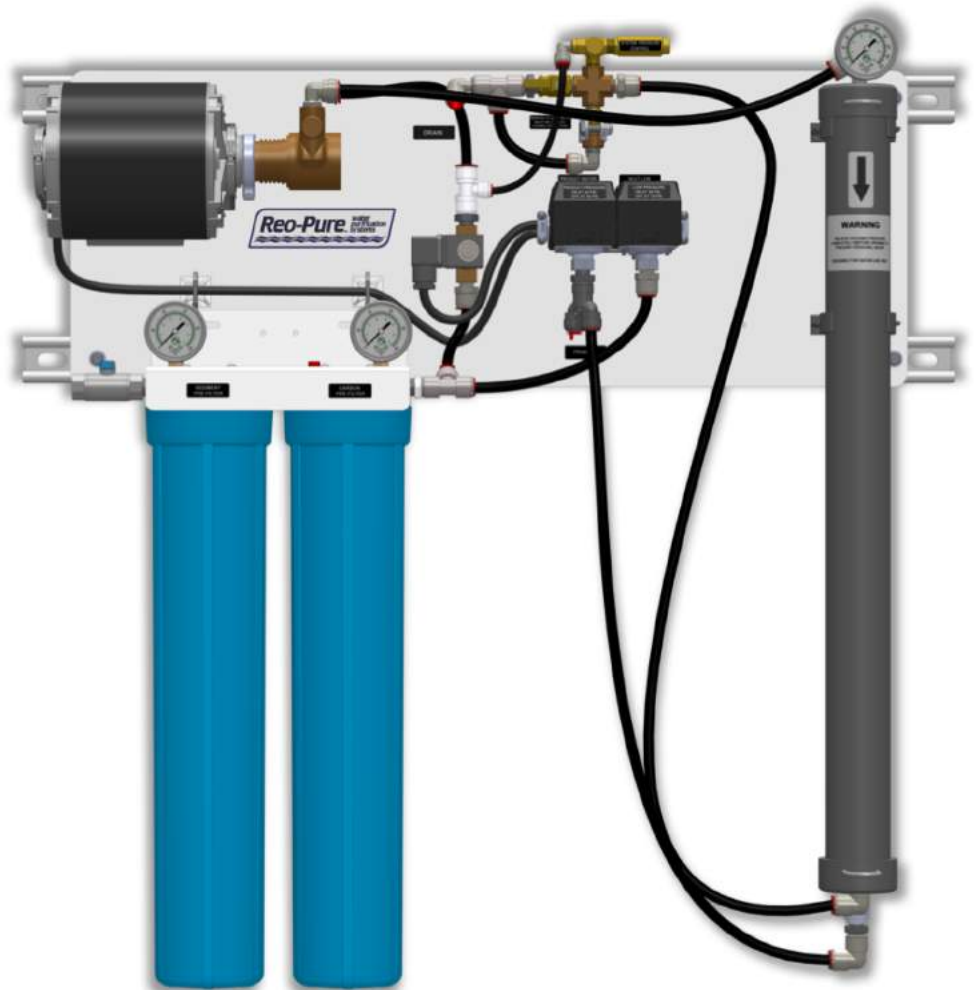

LP3WMS500UM-03142018

Please read this manual carefully *BEFORE* attempting installation.

# TABLE OF CONTENTS

## Reo-Pure LP3-WMS 500 Model



### Getting to Know Your Reo-Pure R.O. System

Major Component Diagram.....	2
------------------------------	---

### Introduction

How Reverse Osmosis Works.....	3
Definition of Terms.....	3
Factors Affecting System Operation and Performance.....	3

### Systems Specifications

Operating Specifications.....	4
Feed Water Parameters.....	4
Design Test Conditions.....	4
Design Specifications.....	4
Weight & Dimensions.....	4

### Installation Instructions

Unpacking Your Reo-Pure System.....	5
Locate Desirable Installation Site.....	5
Feed Water Supply Connection.....	5
Product Water Connection.....	5-6
Drain/Reject Water Connection.....	6
Electrical Connections.....	6
Install Filter Cartridges.....	6
John Guest Locking Clips.....	6

### Start-Up Procedure

Installation Follow-Up.....	7
Pretreatment for the RO System.....	7
Divert Product Water to Drain.....	7
Flush the System.....	7
Adjust the System Pressure.....	7
Check the Inlet Low Pressure Switch.....	7
Purge the System.....	7
Check the Product Water Pressure Switch.....	8
Product Water Connection.....	8
Final Inspection.....	8

### Routine Maintenance Procedures

Filter Cartridge Installation and Replacement.....	9-10
System Pressure Switches.....	11
Servicing the Membrane Element.....	12
Sanitizing the System.....	13

Major Components Replacement List.....	14
--	----

### Reo-Pure Optional Features

Automatic Flush Timer.....	15
Inline TDS Monitor.....	16
Tank Level Float Control Switch.....	17

Reo-Pure System Limited Warranty.....	18
---------------------------------------	----

System Trouble Shooting.....	19-20
------------------------------	-------

Flow and Electrical Schematics.....	21-22
-------------------------------------	-------

System Log Sheet.....	23
-----------------------	----

# GETTING TO KNOW YOUR REO-PURE R.O. SYSTEM

LP3-WMS 500 System with Standard Features

*It is important to familiarize yourself with your new Reo-Pure™ Reverse Osmosis System.*

Pictured below is a front and rear view of the system, with the main components identified. These components will be referenced to throughout the manual. Noting their location will assist you in the startup and maintenance of the R.O. System.

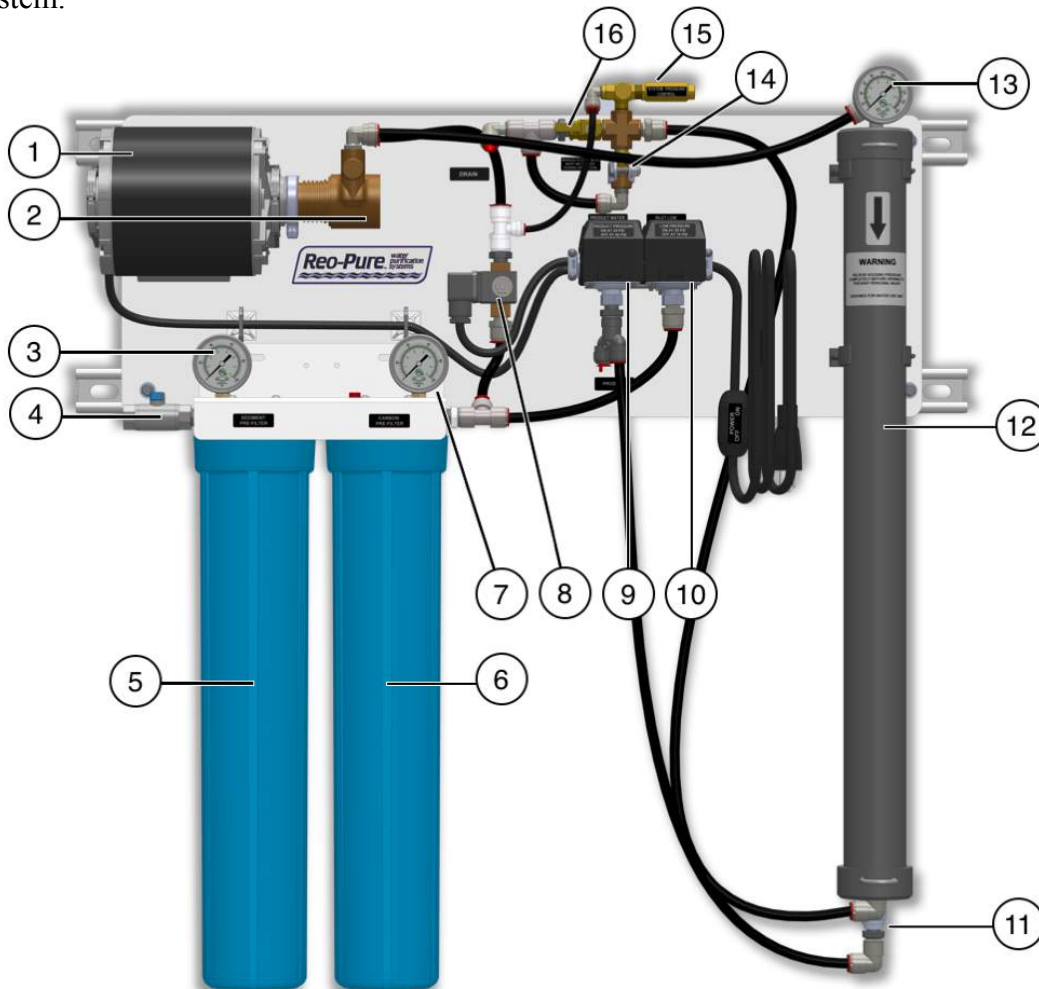

## MAJOR COMPONENTS

- |  |  |
|--|--|
| 1. Motor   | 9. Product Water Pressure Switch   |
| 2. Rotary Vane Pump  | 10. Inlet Feed Water Low Pressure Switch                                     |
| 3. Pre-Filter Pressure Gauge   | 11. Product Water Check Valve, PVC   |
| 4. Feed Water Manual Shut-Off Valve  | 12. Membrane Pressure Vessel, PVC<br><i>Membrane Element (inside vessel)</i> |
| 5. Pre-Filter Housing<br><i>Sediment Cartridge, 5-micron (inside housing)</i>      | 13. System Operating Pressure Gauge  |
| 6. Pre-Filter Housing<br><i>Carbon Block Cartridge, 10-micron (inside housing)</i> | 14. Reject Flow Control Assembly   |
| 7. Post Filter Pressure Gauge  | 15. System Operating Pressure Regulator                                      |
| 8. Inlet Solenoid Valve, with Coil   | 16. Manual Membrane Flush Valve  |

**IMPORTANT** – This manual covers the installation, operation and maintenance of the Reo-Pure™ LP3-WMS 500 Reverse Osmosis System. It is important to read this manual thoroughly *BEFORE* installing the system. For systems that are equipped with optional features, refer to the appropriate optional feature section, located at the end of the manual.

---

# INTRODUCTION

---

Your Reo-Pure System has been designed to produce quality water for a variety of applications. We are confident that you will find Reo-Pure Systems provide quick and simple installation, hassle-free maintenance, and years of reliable and trouble free operation.

Reo-Pure Systems incorporate years of engineering experience, dedicated workmanship, and quality manufactured components. Each system is built with pride and is factory tested for superior performance.

As with all products, the customer has the responsibility to ensure that the Reo-Pure System is operated under proper conditions and within design limitations. All installation, startup and maintenance instructions must be followed carefully.

## HOW REVERSE OSMOSIS WORKS

Reverse osmosis is a separation process in which water is forced under pressure through a membrane in the opposite direction from normal. The membrane allows water to pass through and blocks or hinders the passage of dissolved substances and suspended particles. This process reduces the dissolved salts, minerals, and suspended particles, while improving the taste, odor, and clarity of the water. The process is further enhanced by allowing the feed water to continuously pass over the surface of the membrane, sweeping away the concentrated salts, minerals and suspended particles.

The Reo-Pure membrane element divides the feed water into two streams: product water (permeate) which is now purer than before, and is the desired result; and concentrate water (reject or drain, plus recirculation) which carries the concentrated dissolved salts, minerals, and suspended particles that were rejected by the membrane element down the drain.

## DEFINITION OF TERMS

**Feed Water** – The incoming water to be processed by the Reo-Pure System.

**Product Water (Permeate)** – The portion of the feed water that has passed through the membrane element. It is the desired result of a Reo-Pure System.

**Concentrate Water (Reject or drain water, plus recirculation)** – Used to describe the portion of feed water that has flowed across the membrane (not through), and has not been converted to product water. This water now contains a higher concentrate of dissolved solids and may also contain organic matter and suspended particles rejected by the membrane. The concentrate is then split into two streams, reject and recirculation. The recirculated water is mixed with the feed water on the inlet side of the pump. The reject water

is sent down the drain. This design is used as a way to minimize the amount of water sent to drain.

**Recovery** – The percentage of feed water that becomes product water. The recovery rate is determined by the number of gallons (or liters) of product water divided by the total gallons (or liters) of feed water, and multiplied by 100.

**Percent Rejection** – The percentage of dissolved solids in the feed water that does not pass through the membrane. The membrane prevents passage of dissolved solids and other contaminants into the product water.

**Conductivity** – The property of a substance to conduct or transmit electricity. The unit of measure is in mhos and is commonly used to determine the purity or quality of water. In the water treatment industry, it is often converted to PPM TDS (Parts Per Million Total Dissolved Solids).

## FACTORS AFFECTING SYSTEM OPERATION AND PERFORMANCE

**Feed Water Temperature** – The volume of product water increases with higher feed water temperatures, and decreases with lower feed water temperatures. Temperatures below 35°F could crack the membrane element, and temperatures exceeding 90°F may cause rapid deterioration. The recommended range is between 45°F and 90°F.

**Feed Water Pressure** – The recommended range is between 40 PSI and 85 PSI. This is the most common range of municipal water supplies.

**Hydrolysis** – The natural chemical breakdown of membrane elements when in contact with water. This breakdown is accelerated when the water temperature is above 90°F, when the pH is not within the tolerable range, or when hydrogen sulfide is present. Refer to the System Operating Specifications section of this manual. Additional pre-treatment may be required in these cases.

**Bacteria** – R.O. Systems may be exposed to bacteria if operated intermittently. Following a prolonged shutdown or storage period, the system should be sanitized. Refer to the section in this manual regarding sanitization.

**Fouling or Surface Coating of the Membrane Element** – Fouling is a common problem with membrane elements as a result of salts, hardness, iron, etc. collecting on the membrane surface. The pores and channels of the membrane element become plugged reducing the water production rate. Pre-treatment equipment, such as a water softener, iron filter, or activated carbon filter will reduce membrane element fouling and extend its life.

# SYSTEM SPECIFICATIONS

## OPERATING SPECIFICATIONS

- Production Rates:** 500 GPD (1,893 LPD)\*  
0.347 GPM (1.315 LPM)\*
- Rejection Rate:** Minimum 95% – Maximum 99%
- Low Feed Water Pressure Switch:** System shuts down at 15 PSI decreasing pressure
- Product Water Pressure Switch:** System shuts down at 45 PSI ~ System starts at 25 PSI
- Electrical:** Standard – 120V, 60Hz, 1Ph (Optional – 220V, 50Hz, 1Ph)
- Operating Pressure:** 150 PSI

\*System production may vary depending upon incoming water temperature and chemistry.

## FEED WATER PARAMETERS

*Systems are designed for use with potable water sources only*

- Hardness:** Maximum 10 GPG (Over 10 GPG should be softened)
- Iron:** Maximum 0.01 PPM (Dissolved Only)
- Turbidity:** Maximum 1 NTU
- Hydrogen Sulfide:** Must be removed
- Chlorine:** Maximum 0.1 PPM
- Inlet Feed Water Pressure:** Minimum 40 PSI Maximum 85 PSI
- pH Range:** 4 to 10
- Feed Water TDS:** Consult Reo-Pure Manufacturer if TDS exceeds 2,000 PPM
- Temperature:** Minimum 45°F – Maximum 90°F
- Max Operating Pressure:** 180 PSI

## DESIGN TEST CONDITIONS

- Operating Pressure:** 150 PSI
- Feed Water TDS:** 500 PPM as NaCl
- Design Temperature:** 77°F (25°C)
- Membrane Element:** TFC Polyamide – High Flux
- Design Recovery:** 50%

## DESIGN SPECIFICATIONS

Operating Pressure	Inlet Conn.	Product & Reject Conn.	Filter Housings	Membrane Element	Motor 60 Hz	Pump
150 PSI	3/8" NPTF	3/8" Tube	20" SL	2" x 26"	1/4 HP	60 GPH

## WEIGHT AND DIMENSIONS

Installation Dimensions						
Weight	Height		Width		Depth	
	In	Cm	In	Cm	In	Cm
75	41	105	34	86	8	21

\* Add 6" to width if AutoFlush feature is included.

# INSTALLATION INSTRUCTIONS

**IMPORTANT** – Installation must comply with state and local plumbing, electrical, and sanitation codes.

**IMPORTANT** – Do not use this system to make drinking water from non-potable water sources. Do not use the system on microbiologically unsafe water, or water of unknown quality without adequate disinfection before or after the system.

Reo-Pure RO Systems will operate most efficiently on filtered water with a pH of less than 6.5, an SDI of 5 or less, and hardness of less than 10 GPG. If the system is operated with levels higher than these, other forms of pretreatment may be necessary.

Feed water must not contain free chlorine, formalin, quaternary germicides, cationic surfactant, detergents containing non-ionic surfactant, such as ALL or Triton, or membrane element cleaners other than those approved for use.

## UNPACK YOUR REO-PURE SYSTEM

Reo-Pure Systems are carefully inspected, tested, and packaged. They are shipped in proper working order and in excellent condition. Remove the system from the shipping carton/container and inspect it for signs of concealed damage, which may have occurred during shipping. If damage has occurred, immediately contact the delivering carrier and file a claim for damages.

## LOCATE DESIRABLE INSTALLATION SITE

The Reo-Pure™ LP3-WMS System must be mounted securely to a wall capable of supporting its weight. See System Specifications section of this manual for weight. A minimum of four bolts must be used. They should be placed through the slots on the ends of the top and bottom frame. Allow adequate

space around the system for routine maintenance, such as replacing filter cartridges and membrane elements.

## FEED WATER SUPPLY CONNECTION

A cold water supply source must be located within close proximity to the system. This will be the inlet feed water supply. Feed water pressure must be a minimum of 35 PSI.

The manual feed water shut-off valve was shipped loose with the system. Wrap the male end of the valve with Teflon tape and screw it into the sediment pre-filter marked **INLET**. Connect the feed water supply source to the 3/8" NPTF shut-off valve. We recommend using 3/8" pipe, 1/2" OD tubing, or 3/8" hose.

**CAUTION** – Do not connect a hot water line to the Reo-Pure system. Feed water must be a cold water supply.

## PRODUCT WATER CONNECTION

During the initial start-up procedure, after a membrane element replacement, or after sanitization of the system, you will want to divert the product water line to your wastewater drain. This can be done by either installing a 3-way valve in the line or by disconnecting the tubing to your storage tank. It is always important to divert the product water to drain for 30 to 60 minutes of operation, because membrane elements are treated with preservative solution that should be rinsed free.

*(continued on next page)*

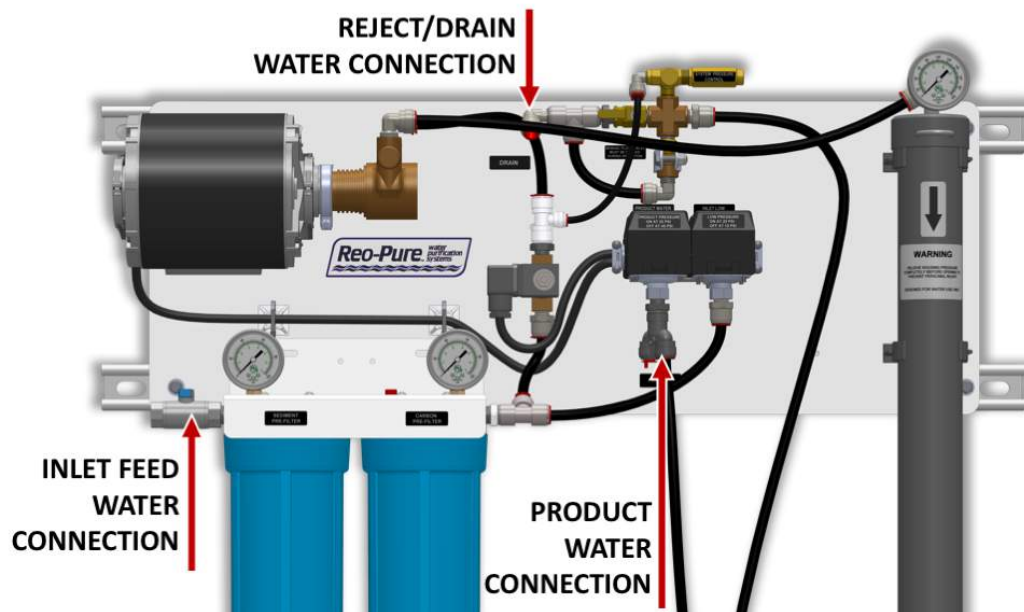

---

# INSTALLATION INSTRUCTIONS *(continued)*

---

If a pressurized storage tank is being used, the system is equipped with a product water pressure switch, which will shut the system off when the pressure in the tank reaches 45 PSI. The system will turn on again when the pressure in the tank decreases to 25 PSI.

If an atmospheric storage tank is being used, a tank level float control switch and repressurization system (optional features) will be required to shut the system off and to pump the product water to your application.

Remove the plug from the product water outlet (marked **PRODUCT**) located in the two-way divider at the bottom of the product water pressure switch. Connect a 3/8" OD product water line to the marked outlet, but do not connect it to the storage tank or other dispensing system at this time. There will be further instructions in the System Start-Up Section regarding additional steps required, prior to connecting the storage tank.

## DRAIN / REJECT WATER CONNECTION

A wastewater drain must be near the installation site. This will be your connection for the reject water (drain) which is carrying a high level of concentrated dissolved salts, minerals, and suspended particles that were rejected by the membrane element.

Remove the plug from the drain water outlet (marked **DRAIN**) at the bottom of the reject water assembly, located near the center of the unit. Using 3/8" OD tubing connect this outlet port to your wastewater drain.

**NOTE: We recommend installing an air gap connection designed to prevent wastewater back flow.**

## ELECTRICAL CONNECTIONS

A grounded electrical supply of the proper voltage for your system should be near the installation site. The system will be damaged if connected to a power source other than the voltage, phase and hertz specified on the serial number label. See the wiring diagram at the end of this manual for the correct power connections.

Every LP3-WMS Series 60Hz, 120V, 1Ph model comes equipped with an In-Line On/Off Toggle Switch – conveniently located next to the system pressure switches. Please reference the wiring diagram at the end of this manual for more information.

**CAUTION** – While the On/Off Toggle Switch may be in the OFF position, the power cord should still be unplugged for any servicing or maintenance to the Reo-Pure™ RO System.

**Optional 50Hz, 220V, 1Ph Power** – If your system was ordered with the optional 50Hz, 220V, 1Ph feature, you will

need to provide your own electrical plug. Attach the appropriate plug to the end of the 14-3 cord that is connected to the Inlet Feed Water Low Pressure Switch.

**CAUTION** – A water softener should not be allowed to regenerate while the Reo-Pure System is operating, unless safeguards are used to be sure the system is shutdown or operating on an alternate source of softened water.

**CAUTION** Connecting the system to a power source that does not match the system power rating exactly can damage the system and void the warranty.

## INSTALL FILTER CARTRIDGES

Please refer to the section titled “Filter Cartridge Installation and Replacement” in this manual.

## JOHN GUEST LOCKING CLIPS

To ensure the highest level of reliability and system longevity, red locking clips have been installed on all John Guest tubing connections. This will make the connections more secure and protect the system from accidental disconnects. Two extra locking clips have been included with this manual. These should be attached at the product and drain ports of the system, after you have made your connections.

**IMPORTANT** – Installation must comply with state and local plumbing, electrical, and sanitation codes.

**IMPORTANT** – Prior to the start-up of system, visually inspect the inlet, drain, and product water connections completely. Also check to be sure the system is connected to a properly grounded electrical power supply with the appropriate voltage, phase, and hertz.

---

# START-UP PROCEDURES

---

## INSTALLATION FOLLOW-UP

1. Visually inspect the water connections.
2. Be sure filter cartridges have been installed.
3. Confirm connection to the proper power source.

**NOTE: The membrane element(s) will have been installed in the system during the final testing procedures unless other arrangements have been made with the manufacturer.**

## PRETREATMENT FOR THE RO SYSTEM

A water analysis of your feed water should have been performed to determine what type of pretreatment may be required. See Feed Water Parameters for this system before operating this system.

## DIVERT PRODUCT WATER TO THE DRAIN

During the initial start-up of the system, it is important to divert all of the product water to a wastewater drain for approximately 30 to 60 minutes. Membrane elements are treated with a preservative solution and should be thoroughly rinsed clean before water is retained for use. This can be done either by installing a 3-way valve in the product water line or by diverting your product water line to drain. Do not connect the product water line to a storage tank at this time.

## FLUSH THE SYSTEM

**Standard System With Manual Flush** - Open the inlet feed water shut-off valve and allow the system to fill with water. Press the pressure relief button to release the air from the filter housings, and open the manual flush valve.

Plug the power cord into the wall outlet. The inlet solenoid valve will open, and the pump will start. When the system is turned on, the solenoid valve automatically opens. The valve will close when the system is turned off. The system will only start with sufficient feed water flow and pressure (minimum 35 PSI). Low inlet feed water flow and low pressure can result in damage to the system.

Allow the system to run approximately 3 to 5 minutes to bleed all trapped air and to flush the membrane element. Then, close the manual flush valve.

**IMPORTANT MAINTENANCE** – Depending on the quality of your feed water, we recommend the manual flush valve be opened at least once a week for 3 to 5 minutes to rinse the membrane element.

**System With Optional AutoFlush Feature** - If your system is equipped with the optional Automatic Timed Flush feature, the manual flush valve will be eliminated. In place of the manual flush valve is a Flush solenoid valve. The solenoid is wired to the electrical enclosure and is pre-set so that a one-minute flush will occur every time the system goes into operation. A one-minute flush will also occur every 2 hours the system runs constant.

Open the inlet feed water shut-off valve and allow the system to fill with water. Press the pressure relief button to release the air from the filter housings. Plug the power cord into the wall outlet and the system will start with a one-minute automatic flush. You may want to repeat this step to insure the membrane element is thoroughly rinsed. After the flush cycle has stopped, proceed to the next step.

## ADJUST THE SYSTEM OPERATING PRESSURE

Adjust the system pressure regulator so that the system pressure gauge reads 150 PSI. Turn the pressure regulator clockwise to increase the pressure, and counterclockwise to decrease the pressure.

**CAUTION** – Never allow the Reo-Pure system pressure to exceed 180 PSI

This Reo-Pure System was designed to operate at 50% recovery. The gallons per day of product water produced will vary based on the feed water TDS, feed water temperature, and the backpressure on the system.

Measure the amount of time in seconds it takes for the system to produce 1 quart of product water. Use the following formula to calculate the gallons per day: 21,600 divided by the seconds it took to produce one quart, equals the gallons per day.

**IMPORTANT** – Frequently check the system for any leaks that may develop.

## CHECK THE INLET LOW PRESSURE SWITCH

The inlet feed water low-pressure switch is preset at the factory. Its purpose is to prevent damage to the system if there is inadequate feed water flow or pressure.

This step is to verify that it is functioning properly. Slowly decrease the inlet feed water supply by closing the manual feed water shut-off valve, while watching the pre-filter outlet pressure gauge. If the system shuts down when the pressure drops to approximately 15 PSI, then the inlet pressure switch is functioning correctly. If it is not functioning correctly, refer to the Section of this manual on System Pressure Switches.

## PURGE THE SYSTEM

Allow the system to operate approximately 30 to 60 minutes diverting the product water to drain. Once all of the membrane preservative is flushed from the system, product water may be retained for use.

*(continued on next page)*



---

## SYSTEM START-UP PROCEDURES *(continued)*

---

### **CHECK THE PRODUCT WATER PRESSURE SWITCH**

If your system is equipped with a product water pressure switch, it is preset at the factory to shut the system down at 45 PSI, and restart the system at 25 PSI. Its purpose is to stop and start the system when a pressurized storage tank is used. If the product water pressure switch is not shutting down the system when the pressurized storage tank is full, refer to the section in this manual titled “System Pressure Switches.”

### **PRODUCT WATER CONNECTION**

For convenience, we recommend installing a tank shut-off valve prior to the pressurized storage tank. The storage tank may take several hours to fill with product water.

### **FINAL INSPECTION**

Once the above procedures are completed, visually inspect all water connections. Check to be certain that all connections are tight and secure.

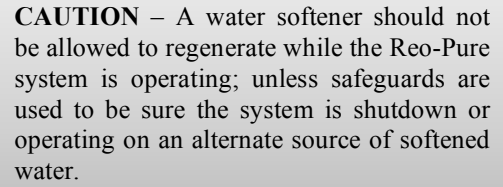

**CAUTION** – A water softener should not be allowed to regenerate while the Reo-Pure system is operating; unless safeguards are used to be sure the system is shutdown or operating on an alternate source of softened water.

# FILTER CARTRIDGE INSTALLATION & REPLACEMENT

## FILTER CARTRIDGE INSTALLATION

This Reo-Pure System includes two pre-filter cartridges: the 5-micron sediment pre-filter cartridge that collects sediment, and the carbon block pre-filter cartridge that reduces undesirable tastes, odor and chlorine.

**NOTE: The sediment cartridge and the carbon block cartridge have been packaged separately and will need to be installed prior to start-up.**

1. Remove the filter cartridges from their packaging.
2. Remove the filter sumps by turning clockwise.
3. Place the sediment cartridge over the standpipe in bottom of the filter sump for the **Sediment Pre-Filter**, and place the carbon block cartridge over the standpipe in bottom of the sump for the **Carbon Pre-Filter**. (See diagram at right)
4. Replace the filter sumps on the filter housing caps, making sure that the sediment filter is positioned below the **Sediment Pre-Filter** label, and the carbon block filter is positioned below the **Carbon Pre-Filter** label. **DO NOT OVER TIGHTEN.**

**NOTE: The membrane element(s) have been installed in the system during the final testing procedures, unless other arrangements have been made with the manufacturer.**

**CAUTION** – It is important that the o-ring be properly seated each time the filter housing is reassembled or removed. Use only food grade silicone or glycerin to lubricate the o-rings. Do not use a petroleum-based product such as Vaseline.

## CHANGING FILTER CARTRIDGES

Filter cartridges have a limited service life and should be replaced if you experience noticeable changes in product water taste, color, odor, or flow rate. On average, filter cartridges should be replaced about every 3-6 months.

Your Reo-Pure System is equipped with pre-filter inlet and pre-filter outlet pressure gauges. An increase in the pressure difference of 10-12 PSI between the two gauges is an indication that the filter cartridge may need to be replaced.

1. Turn OFF the feed water supply. The Reo-Pure System will shut down.
2. Relieve all the pressure from the system by opening the manual flush valve and pressing the pressure relief button. If your system is equipped with the Automatic Timed Flush feature, press the pressure relief button while the system pressure gradually decreases.
3. Disconnect the main power supply

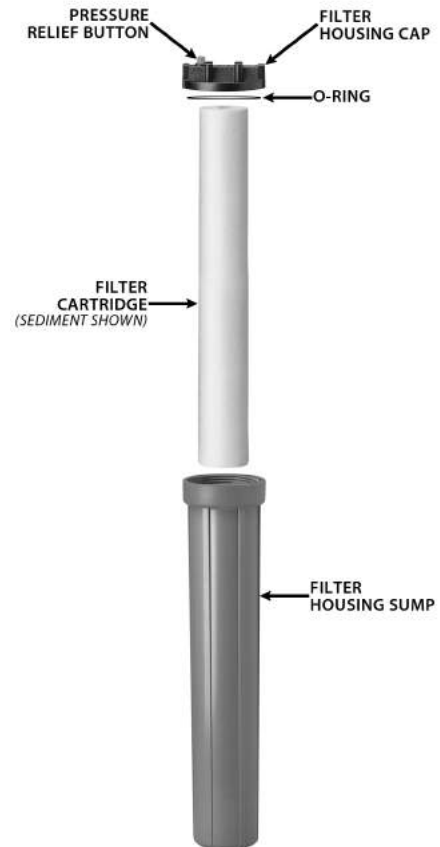

**IMPORTANT:** Before performing any maintenance on your Reo-Pure System, always disconnect the power supply!

4. Remove the filter sumps by turning clockwise. Locate and remove the large o-rings, then wipe them clean of lubricant and set aside. It is common for the o-ring to lift out of the sump and stick to the cap. If the o-ring appears to be damaged or crimped, it should be replaced.
5. Remove and discard the used filter cartridges.
6. Rinse out the bottom of each sump and fill about 1/3 full of water. Add about two tablespoons of bleach and scrub the cap and housing with a non-abrasive cloth. Observe the precautions printed on the bleach container. Rinse thoroughly.
7. Lubricate o-rings with a food grade silicone or glycerin. Place o-rings back into the groove in the sumps and smooth into place with your fingers. This step is important to ensure a proper watertight seal.
8. Place the sediment cartridge over the standpipe in bottom of the filter sump for the **Sediment Pre-Filter**, and place the carbon block cartridge over the standpipe in bottom of the filter sump for the **Carbon Pre-Filter** (See diagram above).

*(continued on next page)*

---

## FILTER CARTRIDGE INSTALLATION & REPLACEMENT *(continued)*

---

9. Replace the filter sumps on the filter housing caps, making sure the filters in the sumps match the corresponding label on the bracket above the caps. **DO NOT OVER TIGHTEN.**
10. Turn on the feed water supply and allow the system to fill with water.
11. Press the pressure relief button to release the air from the filter housings.
12. Open the manual flush valve.
13. Reconnect the main power supply. The system should start. If your system has the Automatic Timed Flush feature, it will perform a one- minute flush at this time. Repeat if necessary.
14. Check for leaks.
15. Flush the system for approximately 3 to 5 minutes while diverting the product water to the drain.
16. Close the manual flush valve.

**NOTE: The manufacturer of the filter housing recommends that the filter sump of all plastic housings be replaced every five years for a clear sump and every ten years for an opaque sump. Date the bottom of any new or replacement sump to indicate the next recommended replacement date.**

**IMPORTANT** – Use sterile procedures when removing or replacing filters and membrane elements, or when working with the tubing containing product water. Contamination can result from bacteria on your hands, tools, or in the air.

# SYSTEM PRESSURE SWITCHES

## INLET LOW PRESSURE SWITCH

System preset to shut down at inlet pressure below 15 psi

An Inlet Low Pressure Switch is installed on every Reo-Pure System. The purpose of this switch is to prevent damage to the pump and/or motor if there is inadequate feed water flow or pressure.

### 1) Verifying Set-Point of Inlet Low Pressure Switch

To verify the setting, slowly decrease the inlet feed water supply by slowly closing the manual inlet shut-off valve while watching the pre-filter outlet pressure gauge. If the system shuts down when the pressure drops to approximately 15 PSI, then the Inlet Low Pressure Switch is functioning correctly.

**CAUTION** – Disconnect the power any time the cover is removed from a pressure switch.

### 2) Adjusting the Inlet Low Pressure Switch Set Point

If it is not set correctly, disconnect the power from the System and remove the black plastic cover of the pressure switch labeled “Inlet Low Pressure Switch”. There are two screws for adjusting the switch settings. **Do not adjust the plastic screw.** Turn the brass screw clockwise to increase both the cut-in and cut-out pressure. Turn it counter clockwise to decrease both the cut-in and cut-out pressure. Turn the screw one half turn only. Temporarily replace the cover, reconnect the power and recheck the setting. Repeat as required.

### 3) Identifying a Broken Low Pressure Switch

Simply, close the inlet feed water valve, and if the System does not shut down, the pressure switch needs replacing.

## PRODUCT WATER PRESSURE SWITCH

System preset to cut-out at 45 psi and cut-in at 25 psi

A Product Water Pressure Switch is a standard feature on Reo-Pure LP3 R.O. Systems. Its purpose is to stop and start the R.O. system when a pressurized storage tank is used.

### 1) Verifying Set-Point of Product Water Pressure Switch

You will need a ball valve and pressure gauge (0-100 psi) assembly with a tube connection the size of the R.O. system product tubing. You will also need a container to catch the product water.

Disconnect the power from the System. Close the pressurized storage tank shut-off valve. Open a valve down stream of the pressurized storage tank to relieve the pressure from the system. Disconnect the tubing from the tank shut-off valve. Connect the ball valve/pressure gauge assembly to this tubing. Open the ball valve and put it into the container. Close the down stream valve. Reconnect the power to the R.O. system. Slowly close the new ball valve. If the R.O. system shuts down when the pressure gauge reaches approximately 45 PSI, the Product Water Pressure Switch is functioning correctly.

### 2) Adjusting the Product Water Pressure Switch

If it is not set correctly, disconnect the power to the R.O. system and remove the black plastic cover of the pressure switch labeled “Product Water Pressure Switch”. There are two screws for adjusting the switch settings. **Do not adjust the plastic screw.** Turn the brass screw clockwise to increase both the cut-in and cut-out pressure. Turn it counter clockwise to decrease both the cut-in and cut-out pressure. Turn the screw one half turn only. Temporarily replace the cover, reconnect the power and recheck the setting. Repeat as required. When the Product Water Pressure Switch is set, reinstall the cover and tighten the locking screw. Disconnect the power, remove the ball valve or ball valve/pressure gauge assembly, reconnect the System and open the tank shut-off valve.

### 3) Identifying a Broken Product Water Pressure Switch

If the system does not shut down when the pressurized storage tank is full, the Product Water Pressure Switch needs replacing.

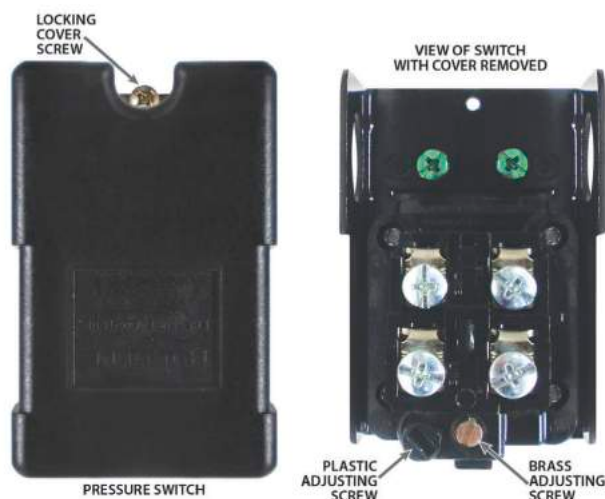

# SERVICING THE MEMBRANE ELEMENT

**NOTE:** Determining how long membrane elements will last is nearly impossible. Normally, replacement is necessary whenever the product water production decreases by 20% at the same operating pressure, or when the TDS exceeds acceptable level.

## MEMBRANE ELEMENT REPLACEMENT

1. Close the manual feed water shut-off valve.
2. The Reo-Pure System will automatically shutdown.
3. Disconnect the main power supply.

**IMPORTANT** – Before performing any maintenance on your Reo-Pure System, always disconnect the power supply!

4. Remove the upper clamp from the pressure vessel.
5. Carefully remove the top end cap from the membrane pressure vessel.
6. The membrane element may come with the end cap. If so, carefully remove it.
7. Remove the membrane element from the vessel by pulling on the product water tube. Normally this can be done by hand. If additional leverage is required, carefully use pliers.

**NOTE:** Observe the arrow on the vessel that shows the direction of flow through the membrane vessel. If the arrow on the vessel points down, then the brine seal on the membrane element should be at the top of the vessel.

8. Check internal and external o-rings on the end caps. If they are worn or damaged, they will need to be replaced.
9. Install the new membrane element in exactly the same manner as it was removed.

**NOTE:** The brine seal end must always face the pressurized feed inlet to the membrane vessel. Please see illustration for more information.

10. Insert the top end cap. Be careful to keep the rubber o-rings in their grooves while inserting the end cap. Use food grade silicone or glycerin to lubricate the o-rings. Do not use a petroleum-based product such as Vaseline.
11. Replace the upper clamp.

**CAUTION** – Be sure your product water line is disconnected from your storage tank before restarting the system. Divert product water to drain for 30 to 60 minutes.

12. Reconnect the main power supply.
13. Turn on the feed water supply using the manual inlet shut-off valve and allow the system to fill with water.
14. Check for leaks.
15. Open the reject water valve and flush the system for 2 to 3 minutes.
16. Close the reject water valve and divert the product water to drain for 30 to 60 minutes.
17. After diverting to drain for 30 to 60 minutes, you may now reconnect the product water line to your storage tank.

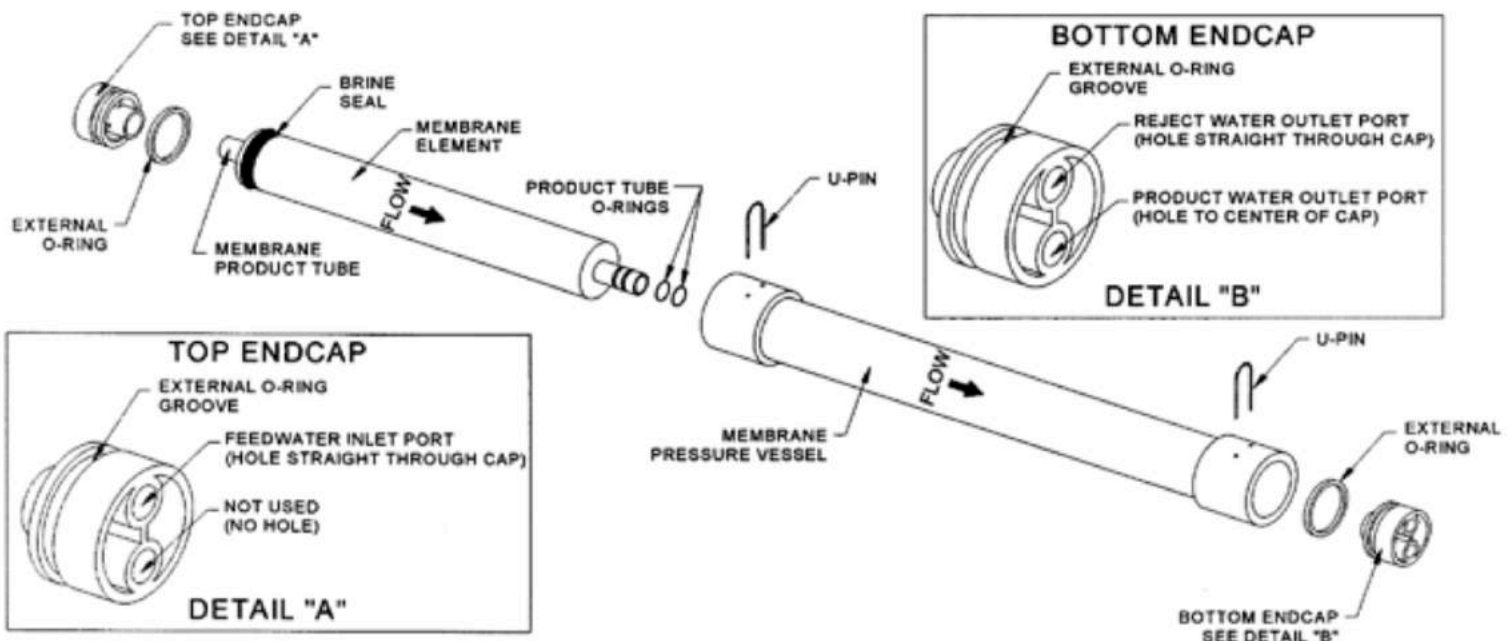

---

# SANITIZING THE SYSTEM

---

The following procedure is recommended for preventive maintenance. It is not intended to be effective in sanitizing highly contaminated systems that have been exposed to excessive amounts of bacteria, or systems that have foul-smelling membrane elements or filters. Such systems require extensive cleaning and sanitizing. Consult your Reo-Pure dealer for further information.

1. Turn off the feed water supply to the system.
2. Disconnect the main power supply.

**IMPORTANT** – Before performing any maintenance on your Reo-Pure System, always disconnect the main power supply!

3. Relieve the pressure from the system by opening the manual flush valve and pressing the pressure relief button. If your system is equipped with the AutoFlush Feature, press the pressure relief button while the system pressure gradually decreases.
4. Remove both filter housing sumps by turning clockwise.
5. Remove and discard the used filter cartridges.
6. Rinse out the bottom of each filter sump and fill about 1/3 full of water. Add about two tablespoons of household bleach and scrub the cap and sump with a non-abrasive sponge or cloth. **Observe the precautions printed on the bleach container.** Rinse the filter sumps.
7. Pour about one tablespoon (two tablespoons if system has AutoFlush Feature) of bleach into the **Sediment Pre-Filter** sump. Reinstall both filter sumps without the filter cartridges, making sure the o-rings are seated properly.

**NOTE: It is important that the o-ring be properly seated each time a filter housing is reassembled or removed.**

8. Empty the product water storage tank and temporarily shut-off the water supply line from the storage tank to the distribution system.
9. Reconnect the power supply.
10. Turn on the feed water supply
11. Close the manual flush valve. If your system is equipped with the AutoFlush Feature, a one- minute flush will occur.
12. Run the system until the product water tank is full, at which point the system will shut off automatically.
13. Turn off the system and let it sit for 8 hours.
14. Turn off the feed water.
15. Empty the product water storage tank.
16. Disconnect the main power supply.
17. Remove the filter sumps as before. Empty them of all chlorinated water.
18. Remove the o-ring from each filter sump and wipe it clean. Lubricate it with food grade silicone or glycerin. Place the o-ring back into the groove in the

sump and smooth it into place with your fingers. This step is important to ensure a proper watertight seal.

19. Place a new sediment pre-filter cartridge over the standpipe in the bottom of the sump for the **Sediment Pre-Filter**, and place a new carbon block pre-filter cartridge over the standpipe in the bottom of the sump for the **Carbon Pre-Filter**.
20. Replace the filter housing sumps on the filter housing caps, by turning counterclockwise – making sure the filters in the sumps match the corresponding label on the bracket above the caps. **DO NOT OVER TIGHTEN.**
21. Turn on the feed water supply and allow the system to fill with water.
22. Reconnect the power supply.
23. Run the system until the product water tank is full, at which point the system will shut off automatically.
24. Check for leaks.
25. Thoroughly flush the system of any residual chlorine by emptying the product water storage tank again and repeating the prior steps.
26. After the system and the storage tank have been thoroughly rinsed of any residual chlorine, you may reconnect your distribution system to the storage tank.

**NOTE: The ONLY time the membrane element should come into contact with chlorine is during this procedure.**

If the product water storage tank is heavily contaminated, it will need to be sanitized separately.



# Replacement Parts List

## LP3-WMS 500 Models

120V/60Hz & 220V/50Hz Models

### MEMBRANE ELEMENT

PART NO.	DESCRIPTION	QTY
7030202601	Membrane Element, 2" x 26"	1

### MEMBRANE PRESSURE VESSEL

PART NO.	DESCRIPTION	QTY
12002026	Membrane Pressure Vessel Assembly, PVC Gray, 2" x 26"	1
120020269	Membrane Pressure Vessel Only, PVC Gray, 2" x 26"	1
12002013	Cap for 2" Gray PVC Vessel, 1 Port, with o-rings	1
12002014	Cap for 2" Gray PVC Vessel, 2 Ports, with o-rings	1
12002015	U-Bolt for 2" Gray PVC Vessel	2
1300224	O-ring for 2" Cap	2

### FILTER HOUSINGS & CARTRIDGES

PART NO.	DESCRIPTION	QTY
22158128-1	Filter Housing, 20" Slim Line, 3/8", with pressure relief, D&T outlet side	1
22158129-1	Filter Housing, 20" Slim Line, 3/8", without pressure relief, D&T inlet side	1
22151121	O-Ring for Slim Line Housings	2
14815508	Sediment Cartridge, 5 Micron, 2.5" x 20"	1
149252010	Carbon Block Cartridge, 10 Micron, 2.5" x 20"	1
22150539	Spanner Wrench for Slim Line Housing	1

### SOLENOID VALVES

PART NO.	DESCRIPTION	QTY
009014120E	Solenoid Valve, Inlet, w/ Coil, 1/4", Brass, 115V/60Hz –for 60Hz Systems	1
009014120E	Solenoid Valve, Auto Flush, w/ Coil, 1/4", Brass, 115V/60Hz –for 60Hz Systems (Optional)	1
009014220E	Solenoid Valve, Inlet, w/ Coil, 1/4", Brass, 220V/50Hz –for 50Hz Systems	1
009014220E	Solenoid Valve, Auto Flush, w/ Coil, 1/4", Brass, 220V/50Hz –for 50Hz Systems (Optional)	1

### PUMPS & MOTORS

PART NO.	DESCRIPTION	QTY
3031501	Pump, Rotary Vane, 3/8" NPT, Brass, with clamp, 60 GPH –for 60Hz Systems	1
3031511	Pump, Rotary Vane, 3/8" NPT, S/S, with clamp, 60 GPH –for 60Hz Systems (Optional)	1
3030301	Pump, Rotary Vane, 3/8" NPT, Brass, with clamp, 105 GPH –for 50Hz Systems	1
3030311	Pump, Rotary Vane, 3/8" NPT, S/S, with clamp, 105 GPH –for 50Hz Systems (Optional)	1
3011113	V-Band Clamp for Pump (replacement only)	1
3100257	Motor, 1/4HP, 115V, 60Hz, 1 phase –for 60Hz Systems	1
3100337	Motor, 1/3HP, 220V, 50Hz, 1 phase –for 50Hz Systems	1

### MISCELLANEOUS

PART NO.	DESCRIPTION	QTY
316063	Check Valve, Product Water, 1/4", PVC	1
4934676	Flow Control Adapter, 1/4"	1
4931322	Flow Control Body, 1/4"	1
491632	Flow Control Orifice Plate	1
4934067	Flow Control Screen, 1/4" & 3/8"	1
71035984	Flow Control Washer	3
008012	Gauge, Pressure, Inlet & Filter, 0-100 psi, 2", Bottom Mount, Liquid Filled	2
008013	Gauge, Pressure, System Operating, 0-300 psi, 2.5", Panel Mount, Liquid Filled	1
3140255	Inlet Feed Water Shut-off Ball Valve, 3/8" 1 NPTF x 3/8" NPTM	1
31402546	Manual Flush Ball Valve, 1/4" NPTF x 1/4" NPTM, Brass	1
1720114	Pressure Regulator, System Operating, 1/4" In, 1/8" Out	1
17506902	Pressure Switch, Low Level Cut-Out	1
17506905	Pressure Switch, Product Water	1
075019	TDS Monitor, In-Line (Optional)	1

# AUTOMATIC FLUSH TIMER *(optional feature)*

If your Reo-Pure System was equipped with an optional Auto Flush Timer, then the manual flush valve will be eliminated. In place of the manual flush valve is an Auto Flush Solenoid Valve.

The solenoid is wired to the electrical enclosure and is pre-set so that a one-minute flush will occur every time the system goes into operation. A one-minute flush will also occur every two hours while the system is in operation.

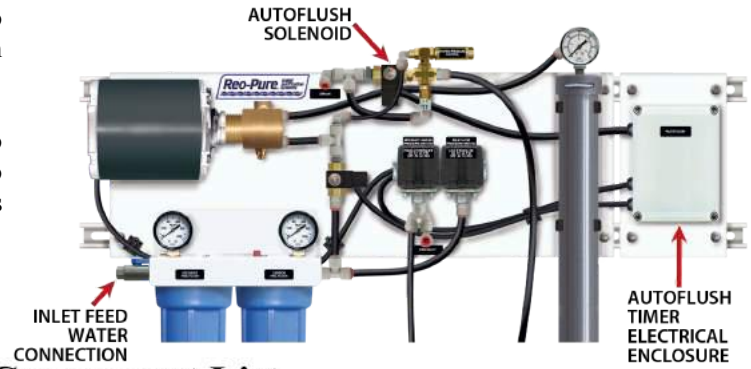

## Electrical Component List

1. Plug
2. On/Off Toggle Switch
3. Low Pressure Switch (N.O.)
4. Product Water Pressure Switch (N.C.)
5. Motor
6. Inlet Solenoid Valve
7. AutoFlush Timer
8. AutoFlush Solenoid Valve
9. Panel Mounted Ground Bar

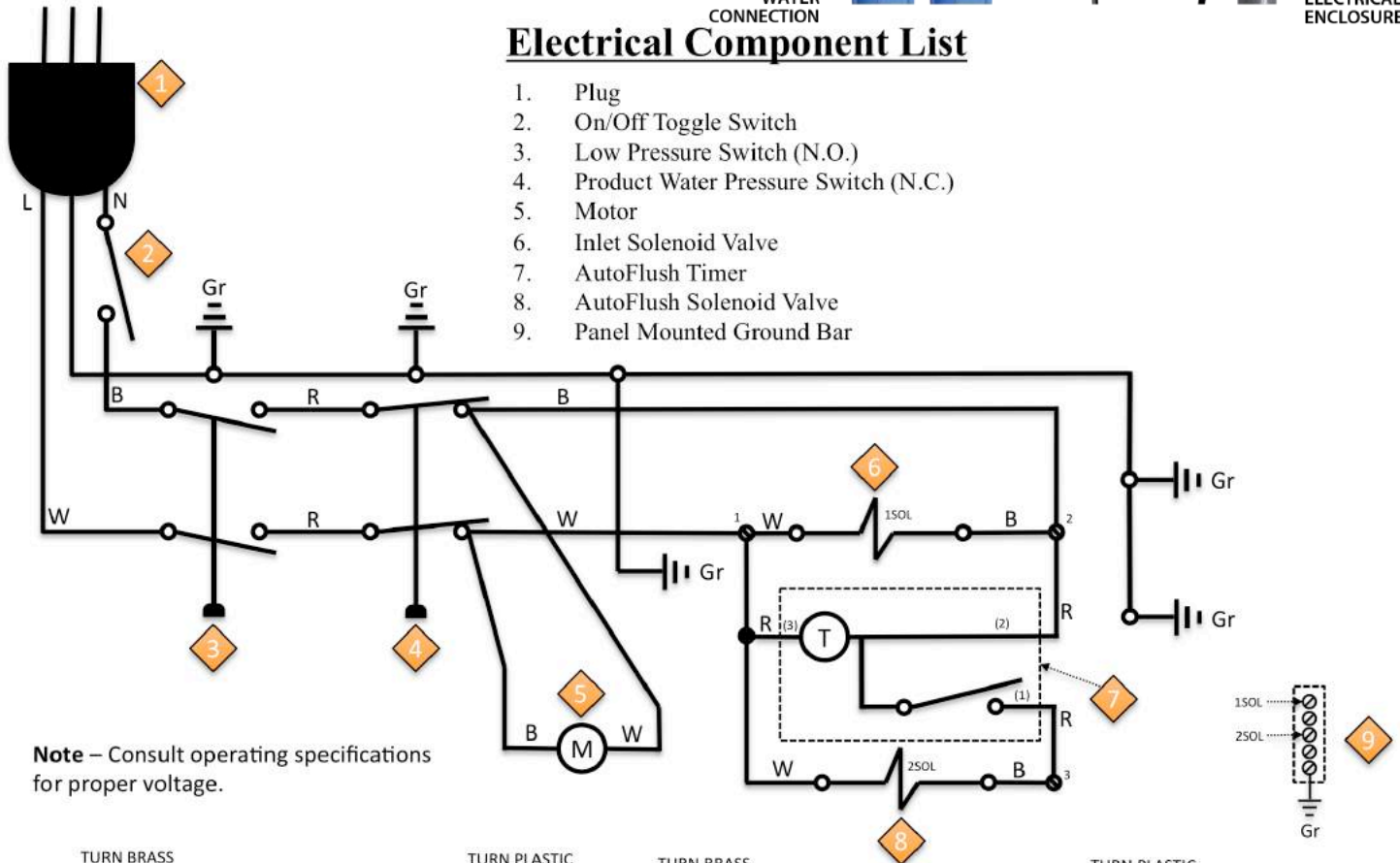

**Note** – Consult operating specifications for proper voltage.

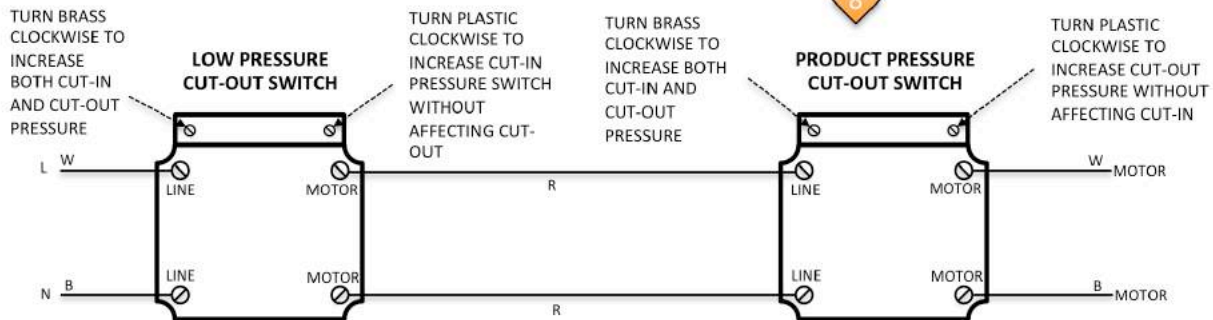



# INLINE TDS TEST MONITOR *(optional feature)*

## THE INLINE TDS TEST MONITOR

The INLINE TDS TEST MONITOR takes the guesswork out of determining system-servicing requirements. By pressing a button, owners may determine if their system is effectively reducing dissolved solids in the water. If dissolved solids rise above acceptable limits, a red light indicates that service is required.

**NOTE: The monitor measures the conductivity of the product water. It will not detect the presence of organic contaminants**

### INSTALLING THE TDS MONITOR PROBE

1. Locate the 3/8" tubing to the faucet. Cut the tube approximately midway with a sharp knife or razor blade.

**CAUTION** – Do not cut the tubing at an angle.

2. Position the tee connector between the cut tubing and firmly insert the tubing into either side of the tee connector.
3. Locate the black cable included with the Monitor Kit. Insert the probe end into the center of the tee connector.
4. Remove the screw on the back of the TDS monitor and remove the back cover.
5. Unwrap and install the 9-volt battery (included) and connect battery to the battery plug.
6. Locate the eight-position selector switch inside of the box. Each position corresponds to a specific TDS setting (See Chart).
7. Push the desired switch setting to "ON". Only one switch should be set to "ON".

#### Definitions:

- TDS - Total Dissolved Solids
- PPM - Parts Per Million

The Inline TDS Test Monitor should be set based upon raw (feed) water characteristics and expected system performance.

For Example: Your municipal water supply has a TDS rating of 200 PPM. You expect to reduce that rating to approximately 10-30 PPM. You would then set the TDS Meter to alert you if the TDS reading was to reach 50 PPM or above. To do so you would set dipswitch 1 to the on position.



## SELECTING THE PROPER TDS SETTING

RAW WATER TDS	PRODUCT WATER TDS AT 85%-95% REJECTION	SUGGESTED ALERT SETTING (PPM)*	DIP SWITCH NUMBER
100 PPM	5-15 PPM	50	1
200 PPM	10-30 PPM	50/75/100	1, 2, or 3
300 PPM	15-45 PPM	75/100	2 or 3
400 PPM	20-60 PPM	100/150/200	3, 4, or 5
500 PPM	25-75 PPM	100/150/200	3, 4, or 5
600 PPM	30-90 PPM	150/200/250/300	4, 5, 6, or 7
700 PPM	35-105 PPM	200/250/300	5, 6, or 7
1000 PPM	50-150 PPM	300/500	7 or 8

\* Settings may vary according to area and dealer recommendations.

Switch No.	1	2	3	4	5	6	7	8
Setting PPM	50	75	100	150	200	250	300	500

8. Replace the back cover and fasten it with the screw.
9. Place the monitor in an easy access location. The only limitation is the length of the cable. Affix the monitor by peeling the tape from the back, then pressing onto desired mounting surface.
10. Plug the cable into the socket on the bottom of the monitor. Bundle the excess cable using the enclosed tie strap.

## OPERATING THE TDS MONITOR

Before operating the TDS Monitor, run at least one cup of water from the drinking water faucet. To test, press the red "Push To Check" button on the front of the monitor, and hold button for three seconds.

If the **GREEN** light glows, the level of dissolved solids is below the monitor set point.

The **RED** light will glow if the level of TDS exceeds the monitor's set point. Drain the holding tank completely and allow it to refill. Then re-test, using the procedure above. If the Red light continues to glow, the unit may require servicing, or the membrane element may need to be replaced. Contact your Reo-Pure Dealer for assistance.

If no light glows, replace the monitor battery. For best results, replace the 9-volt battery once a year.

# TANK LEVEL FLOAT CONTROL SWITCH *(optional feature)*

For use with an atmospheric storage tank application

1. Install Tank Level Float Control Switch in the atmospheric storage tank using the directions that came with the Float Switch.
2. Remove the covers from both the Inlet Low Pressure Switch and the Product Water Pressure Switch by loosening the locking screws, tilting the covers away from the screw and lifting them off.
3. Locate and remove the RED jumper wire between the upper MOTOR terminal on the Inlet Low Pressure Switch and the upper LINE terminal on the Product Water Pressure Switch.
4. Remove approximately 6" of the Tank Level Float Control Switch cord jacket.
5. Loosen the cord grip screw on the cable connector on the Inlet Low Pressure Switch and bring the Tank Level Float Control Switch cord into the switch along side the power cord.
6. Connect the BLACK wire from the Tank Level Float Control Switch cord to the upper MOTOR terminal on the inlet Low Pressure Switch. Pull the WHITE wire from the Tank Level Float Control Switch cord through the chase nipple between the two switches and connect it to the upper LINE terminal on the Product Water Pressure Switch. The use of #8 x 16/14GA insulated fork terminals is recommended. Securely tighten the terminal screws to insure good connection.
7. Tighten the cord grip screw on the cable connector on both cords. Reinstall the covers on the pressure switches and tighten the locking screws.
8. Connect the power to the Reo-Pure system. Follow the Start-Up procedures found in the Reo-Pure R.O. System Installation, Operation and Maintenance Manual.
9. The Tank Level Float Control Switch will now start and stop the Reo-Pure R.O. System based on the level in the atmospheric storage tank.

**CAUTION – DISCONNECT ALL POWER FROM THE REO-PURE SYSTEM BEFORE PROCEEDING.**

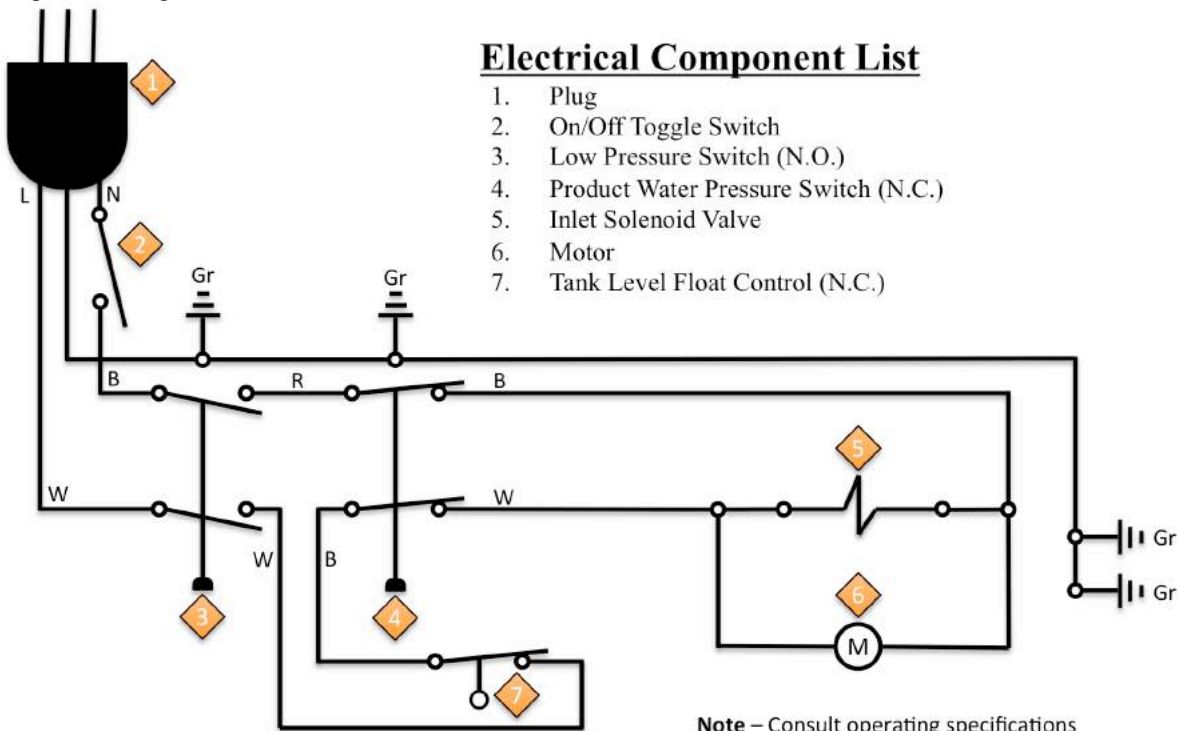

**Note –** Consult operating specifications for proper voltage.

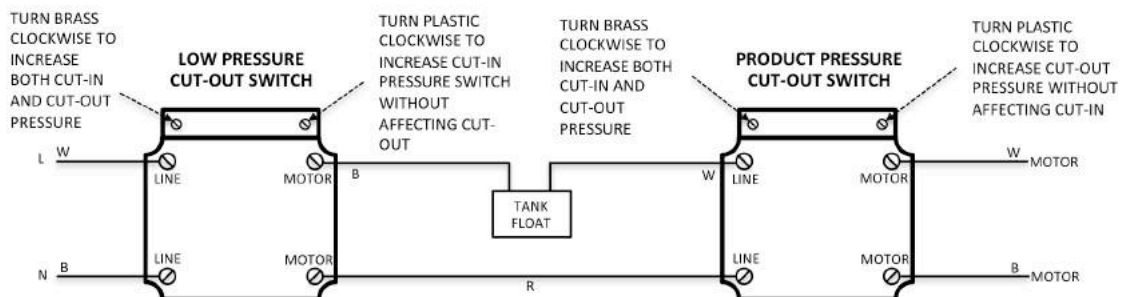

# REO-PURE SYSTEM

## LIMITED WARRANTY

Great Lakes International, Inc. warrants that each REO-PURE system is free of defects in material and workmanship and has been factory tested to perform in accordance with published specifications at the time of shipment. Great Lakes International, Inc. further warrants that the REO-PURE system will continue to operate for a period of one (1) year from start-up, or 15 months from purchase, whichever is shorter, provided that the user supplies feed water meeting minimum standards stated in the REO-PURE Operating Manual and adopts and implements the maintenance program recommended in the REO-PURE Operating Manual.

Parts, which are sold but not manufactured by Great Lakes International, Inc., are subject to the warranty of the manufacturer. Expendable or consumable products, filter cartridges, chemicals, etc., which by nature have a shorter life expectancy than twelve months, are not covered under this warranty.

The Great Lakes International, Inc.'s liability under this warranty is limited to the repair or replacement at Great Lakes International, Inc.'s discretion of systems or components, F.O.B. Great Lakes International, Inc.'s factory, found defective solely as to materials or workmanship during the warranty term. Great Lakes International, Inc. will not be liable for any cost for removal, installation, transportation, or any other charges that may arise in connection with a warranty claim. This warranty does not extend to any system or components which failed due to; 1) Damage from mishandling, misuse, abuse, abnormal operating conditions, improper maintenance procedures, accident, unauthorized modification, or neglect, 2) Improper installation or, 3) Incorrect electrical supply. This warranty is void if serial numbers are mutilated or missing.

Great Lakes International, Inc.'s membrane elements are guaranteed to operate within specifications when used for general water treatment for a period of 12 months from date of purchase providing that the membrane element has not been misapplied or used with feed water that does not meet the minimum standards stated in the REO-PURE Operating Manual.

A membrane element, which fails to perform satisfactorily within the first 30 days after receipt, has not been mishandled or misapplied, and is returned prepaid to Great Lakes International, Inc.'s factory, will be replaced free of charge except for freight and local labor. If a membrane element fails to perform satisfactorily during the balance of the warranty period, and is returned prepaid, Great Lakes International, Inc. will replace the membrane element with a new membrane element and will charge the returner for the portion of the 12 months that the membrane element was used plus the return freight. The pro rata charges will be based on the price prevailing at the time of warranty consideration. Membrane elements must be kept damp at all times and must be clean and bagged in a watertight bag before returning.

To obtain warranty consideration, the defective product must be returned to Great Lakes International, Inc. prepaid together with proof of purchase, installation date, failure date and supporting technical data. All documentation supporting the warranty claim and a Returned Goods Authorization (RGA) number must be included.

GREAT LAKES INTERNATIONAL, INC.'S OBLIGATION UNDER THIS WARRANTY IS LIMITED TO REPAIR OR REPLACEMENT OF THE DEFECTIVE PART. GREAT LAKES INTERNATIONAL, INC. ASSUMES NO LIABILITY WHATSOEVER FOR INCIDENTAL OR CONSEQUENTIAL DAMAGES, LOSSES OR EXPENSES ARISING FROM INSTALLATION, USE OR ANY OTHER CAUSES. THERE ARE NO EXPRESSED OR IMPLIED WARRANTIES BEYOND THOSE WARRANTIES DESCRIBED OR REFERRED TO ABOVE.

Great Lakes International Inc.  
Racine, Wisconsin, U.S.A.

# REO-PURE LP3-WMS 500 SYSTEM TROUBLESHOOTING

PROBLEM	POSSIBLE CAUSE	SOLUTION
<b>RO SYSTEM WILL NOT START</b>	No electrical power	Check power supply
	Storage tank full	Drain portion of water out of tank
	Low feed water pressure	Must be minimum of 35 psi
	Pump/motor malfunction	Check, replace if necessary
	Pressure or float switch defective	Check, replace if necessary
<b>LOW FEED PRESSURE</b>	Feed water valve OFF	Check, open feed water shut-off valve
	Low inlet water pressure	Check, install booster pump if necessary
	Filters clogged	Check pressure on inlet and outlet filter pressure gauges
	Obstructed feed line	Check inlet tubing
	Inadequate upstream pretreatment	Check if sized correctly or fouled
<b>LOW OPERATING PRESSURE</b>	Pressure regulator needs adjustment	Check and adjust if necessary.
	Operating pressure gauge broken	Check, replace if necessary
	Pump impellers worn	Check, replace if necessary
	Pump/motor coupling broken	Check, replace if necessary
	Low water volume to pump	Check, install booster pump if necessary
	Malfunctioning pump	Check, replace if necessary
	Membrane element brine seal is folded or not sealed against housing wall	Check brine seal, use care when reinstalling the membrane into the vessel
	Inlet solenoid valve not opening	Clean solenoid valve or replace
	Membrane element fouled	Check, clean or replace
	Manual flush valve open	Close manual flush valve
<b>THE PUMP DOES NOT RUN</b>	Pump is bound	Manually check pump rotation, replace if necessary.
	Pump/Motor coupling damaged	Remove pump from motor. Check, replace if necessary.
<b>LOW OR NO REJECT WATER / HIGH PUMP PRESSURE</b>	Restricted orifice	Check and clean
	Clogged drain line	Check and clean
	Membrane element clogged or fouled	Check, clean or replace
<b>LOW OR NO PRODUCT WATER</b>	Operating pressure low	Check and adjust
	Membrane element clogged or fouled	Check, clean or replace
	Water temperature too low	Check, consult dealer if necessary
	Product check valve damaged	Check, replace if necessary
	Tank over - pressurized	Check tank air pressure. Relieve to 10 PSI if necessary
	Membrane element installed backward or brine seal damaged/rolled	Check, use care when reinstalling the element into the housing.

*(system troubleshooting continued on next page)*

## REO-PURE LP3-WMS 500 SYSTEM TROUBLESHOOTING *(continued)*

PROBLEM	POSSIBLE CAUSE	SOLUTION
<b>BAD TASTING WATER</b>	Increase in feed water TDS	Check feed water TDS
	Filter cartridges exhausted	Replace filter cartridges
	Tank and system contaminated	Replace filter cartridges and membrane, sanitize system and tank
	Tank contaminated	Re-sanitize tank
	Tank diaphragm ruptured	Replace tank
	Membrane not flushed completely	Flush one or two tanks of product water to drain
<b>CLOUDY WATER</b>	Dissolved air in feed water concentrated in product water	Usually clears up as condition of feed water changes. Letting water stand will allow dissolved air to dissipate
<b>HIGH TDS IN PRODUCT WATER</b>	Membrane element expended	Check, replace if necessary
	Insufficient brine flow rate	Check, reject flow must be at least equal to product flow
	Increase in feed water TDS	Check inlet TDS, see Operating Specifications for rejection rate.
	Product tube o-rings damaged or out of place	Remove membrane element from housing. Re-install or replace o-rings on membrane element product tube

# LP3 SERIES SYSTEM FLOW DIAGRAM

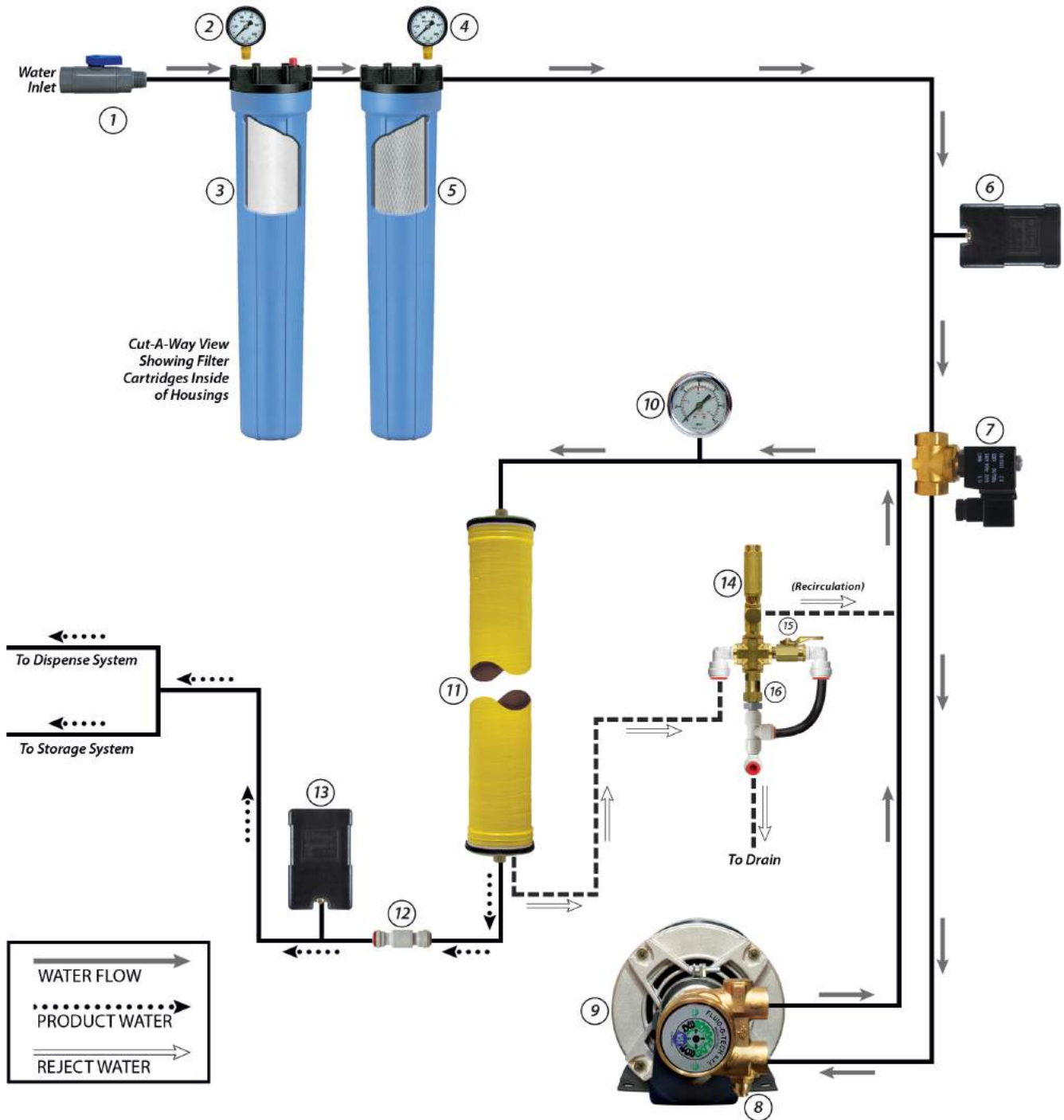

## MAJOR COMPONENTS

- |  |   |
|--|---|
| <ol style="list-style-type: none"> <li>1. Feed Water Manual Shut-Off Valve</li> <li>2. Pre Filter Pressure Gauge</li> <li>3. Pre-Filter Housing<br/>(5-Micron Sediment Pre-Filter Cartridge - <i>Inside housing</i>)</li> <li>4. Post Filter Pressure Gauge</li> <li>5. Pre-Filter Housing<br/>(10-Micron Carbon Block Pre-Filter Cartridge - <i>Inside housing</i>)</li> <li>6. Inlet Feed Water Low Pressure Switch</li> <li>7. Inlet Solenoid Valve w/Coil</li> </ol> | <ol style="list-style-type: none"> <li>8. Rotary Vane Pump</li> <li>9. Motor</li> <li>10. System Operating Pressure Gauge</li> <li>11. Membrane Element</li> <li>12. Product Water Check Valve</li> <li>13. Product Water Pressure Switch</li> <li>14. System Operating Pressure Regulator</li> <li>15. Manual Flush Valve</li> <li>16. Reject Flow Control Assembly</li> </ol> |
|--|---|

# SYSTEM WIRING SCHEMATIC

## Electrical Component List

1. Plug
2. On/Off Toggle Switch
3. Low Pressure Switch (N.O.)
4. Product Water Pressure Switch (N.C.)
5. Inlet Solenoid Valve
6. Motor

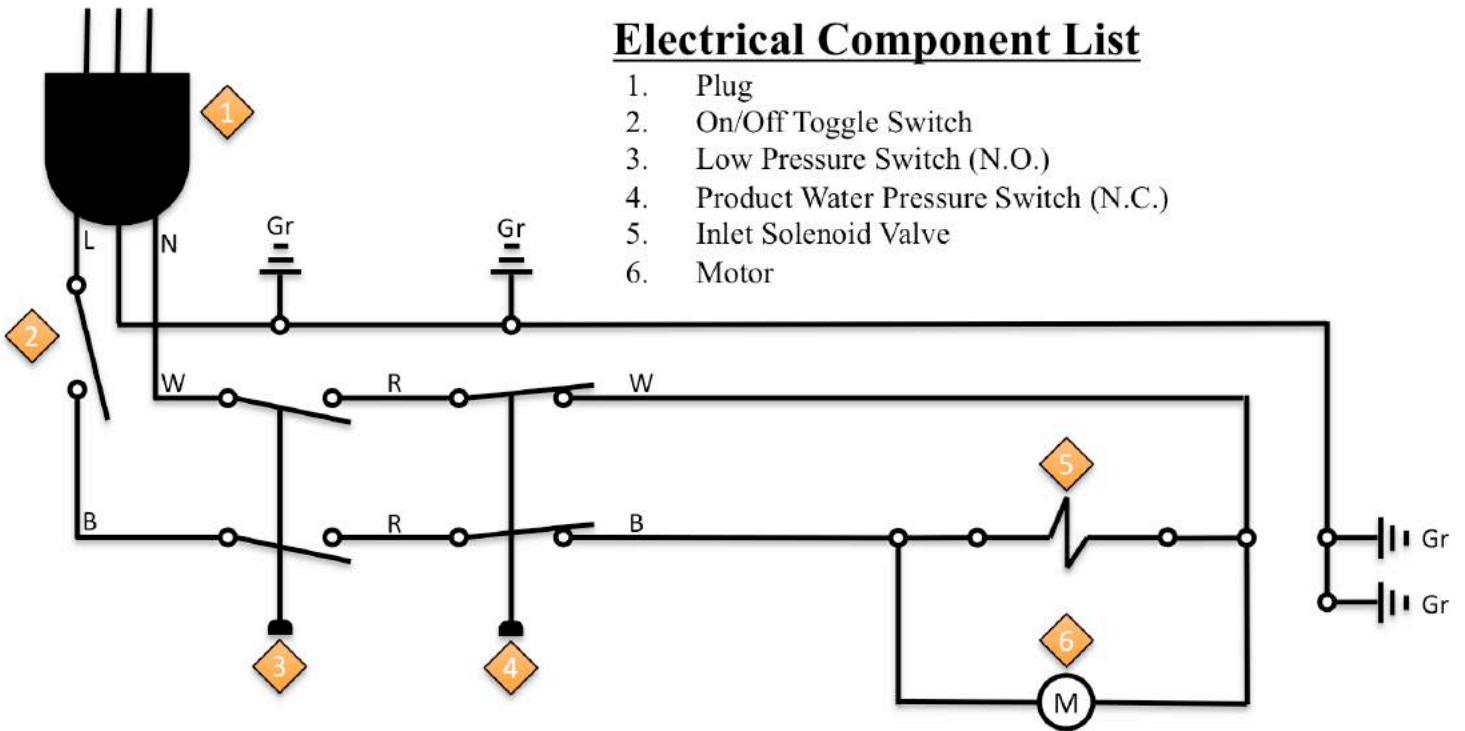

TURN BRASS  
CLOCKWISE TO  
INCREASE  
BOTH CUT-IN  
AND CUT-OUT  
PRESSURE

### LOW PRESSURE CUT-OUT SWITCH

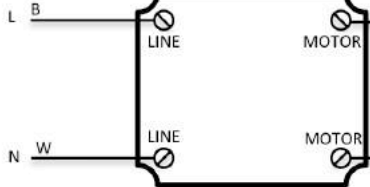

TURN PLASTIC  
CLOCKWISE TO  
INCREASE CUT-IN  
PRESSURE SWITCH  
WITHOUT  
AFFECTING CUT-  
OUT

TURN BRASS  
CLOCKWISE TO  
INCREASE BOTH  
CUT-IN AND  
CUT-OUT  
PRESSURE

### PRODUCT PRESSURE CUT-OUT SWITCH

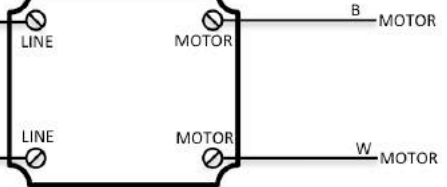

TURN PLASTIC  
CLOCKWISE TO  
INCREASE CUT-OUT  
PRESSURE WITHOUT  
AFFECTING CUT-IN

**Note** – Consult operating specifications for proper voltage.

