

# M1-SERIES REVERSE OSMOSIS SYSTEMS



**M1-12240**  
Reverse Osmosis System

**AXEON® M1-Series Reverse Osmosis Systems** are designed for overall superior performance, high recovery rates, minimal energy consumption and offer great savings with low maintenance and low operation costs.

**The M1-Series Reverse Osmosis Systems** range in capacities from 12,000 to 36,000 gallons per day. To achieve higher recovery rates, each base model includes a concentrate recycle loop. These systems can be upgraded with features such as a variable frequency drive, digital instrumentation, a chemical feed system, blending valve and a permeate divert valve.

## BENEFITS

- Fully Equipped and Customizable
- Skid Mounted
- Components Easily Accessible
- Pre-Plumbed, Wired and Assembled
- Individually Tested and Preserved
- Low Operation and Maintenance Costs
- Easy Maintenance and Servicing
- 20% Less Energy than Standard Membranes
- 1-Year Limited Warranty

## FEATURES

### **Models: M1-4240, M1-6240, M1-8240**

- S-150 Computer Controller
  - LCD Backlit Display
  - Pre-Treatment Lockout
  - Tank Level Input
  - Low and High Pressure Monitoring and Alarm
  - Hour Meter
  - Feed Flush

## FEATURES (CONT.)

### Models: M1-10240, M1-12240

- S-200 Computer Controller
  - LCD Backlit Display
  - Pre-Treatment Lockout
  - Tank Level Input
  - Low Pressure Monitoring and Alarm
  - Hour Meter
  - Dual TDS Monitoring
  - Feed Flush
  - Digital Flow Meters (3)
  - Rejection Percentage
  - Recovery Percentage
- AXEON Permeate and Concentrate Flow Meters<sup>A</sup>
- AXEON Concentrate Recycle Flow Meter<sup>A</sup>
- Stainless Steel Concentrate Globe Valve
- AXEON Pre-Filter 0-100 psi Panel Mounted Glycerin Filled Gauges
- AXEON Pump Discharge and Concentrate 0-300 psi Panel Mounted Glycerin Filled Gauges
- Pentair® Bag Filter Housing
- AXEON 5-Micron Filter Bag
- AXEON HF5-Series Ultra Low Energy Membrane Elements
- AXEON Bag Filter Housing with Stainless Steel Stand
- AXEON FRP-Series Membrane Housings (300 psi)
- Vertical Multi-Stage Stainless Steel Booster Pump
- Feed Solenoid Valve
- Feed Low Pressure Switch
- Clean-In-Place (CIP) Ports
- Permeate Sample Ports
- White Powder Coated Aluminum Frame
- Wooden Shipping Crate

## OPTIONS AND UPGRADES

- S-150 Expander Board<sup>A</sup>
- S-150 Dual TDS Board<sup>A</sup>
- S-200 Computer Controller<sup>A</sup>
- AXEON NF3-Series Nanofiltration Membrane Elements
- AXEON NF4-Series Nanofiltration Membrane Elements
- Hanna® BL 982411 ORP Meter<sup>A</sup>
- Hanna® BL 981411 pH Meter<sup>A</sup>
- S-200 ORP Monitoring<sup>A</sup>
- S-200 pH Monitoring<sup>A</sup>
- Chemical Pump Outlet
- Blending Valve
- High Pressure Tank Switch
- Pump Pressure Relief Valve<sup>B</sup>
- Caster Wheels
- Permeate Divert Valve
- Variable Frequency Drive

### AXEON Naming Matrix

	M1	12	2	40
<b>M-Series Model</b>				
M1 Tap Water Model				
<b>Housing Quantity Designation</b>				
4 4 Vessels				
6 6 Vessels				
8 8 Vessels				
10 10 Vessels				
12 12 Vessels				
<b>Membrane Quantity Per Housing</b>				
2 2 Membranes				
<b>4.0 Inch Membrane Diameter</b>				



**M1-12240**  
Reverse Osmosis System

A. Only available on the following models: M1-4240, M1-6240, M1-8240  
 B. Standard for all 50Hz Systems

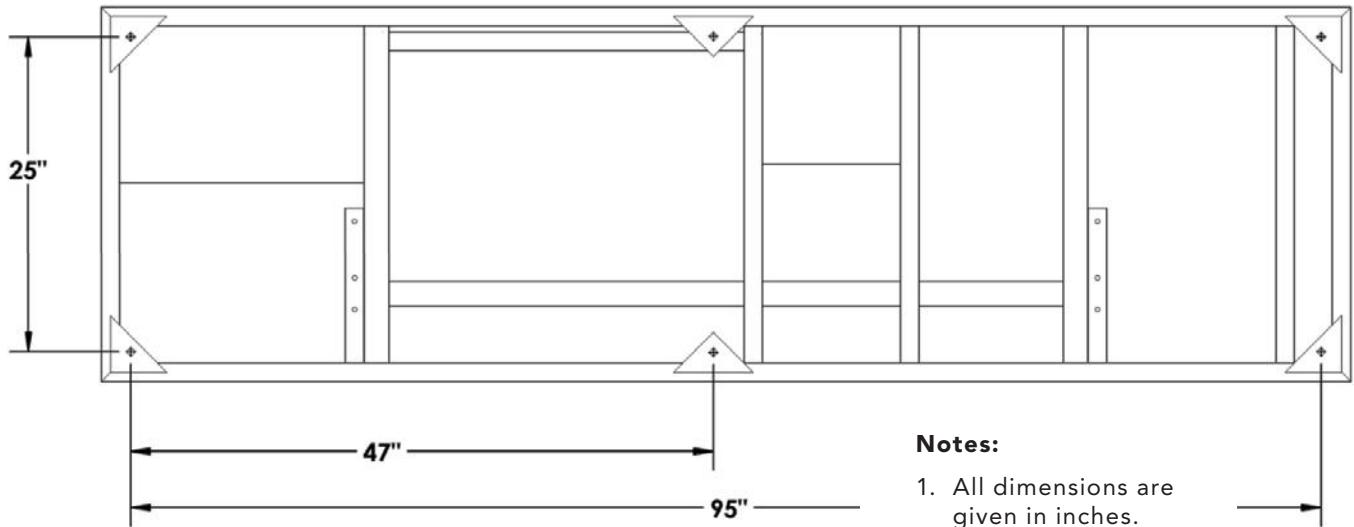
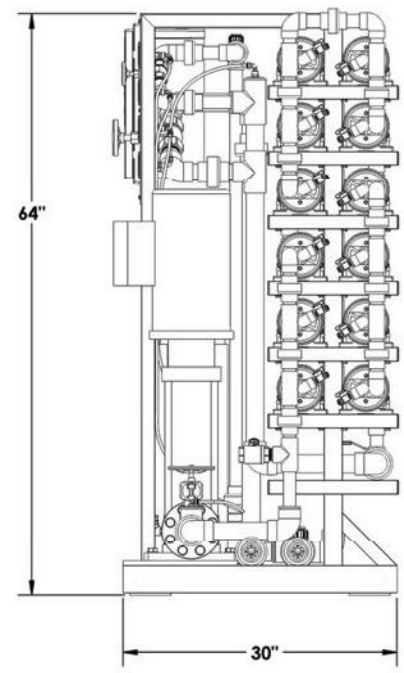
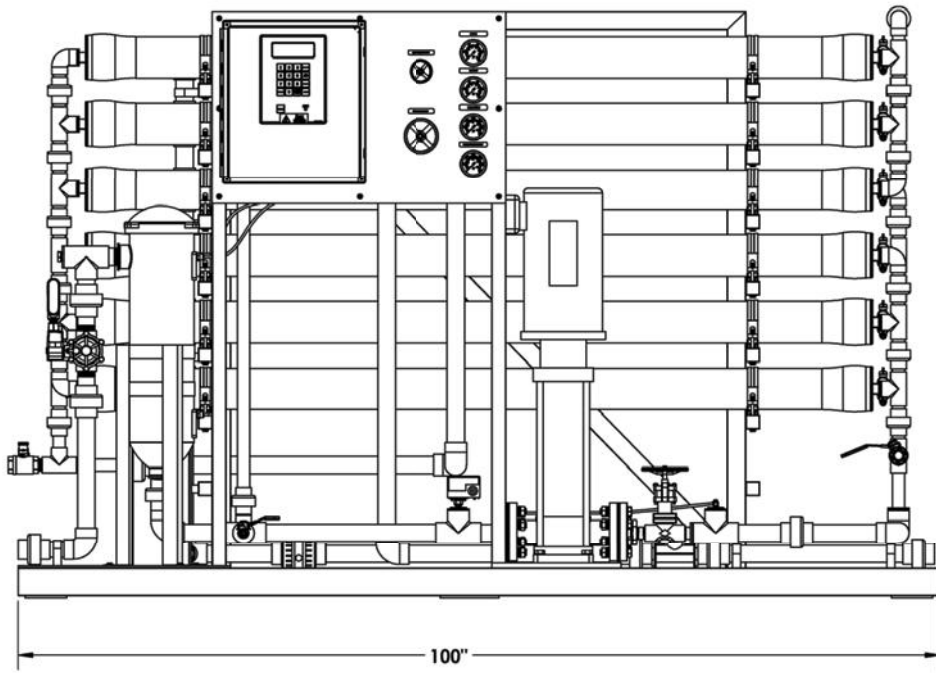

**Notes:**

1. All dimensions are given in inches.
2. Model M1-12240 AXEON model shown.

## ARRAY SPECIFICATIONS

Model	Vessel Array	Vessel Size	Vessel Quantity	Membrane Size	Membrane Quantity
M2-4240	2:2	4080	4	4040	8
M2-6240	2:2:2	4080	6	4040	12
M2-8240	3:3:2	4080	8	4040	16
M2-10240	3:3:2:2	4080	10	4040	20
M2-12240	3:3:2:2:2	4080	12	4040	24

# SPECIFICATIONS

MODELS	M1 – 4240	M1 – 6240	M1 – 8240	M1 – 10240	M1–12240
<b>Design</b>					
Configuration	Single Pass	Single Pass	Single Pass	Single Pass	Single Pass
Feedwater Source <sup>C</sup>	TDS < 2,000 ppm	TDS < 2,000 ppm	TDS < 2,000 ppm	TDS < 2,000 ppm	TDS < 2,000 ppm
Standard Recovery Rate %	50-75	50-75	50-75	50-75	60-75
<b>Rejection and Flow Rates<sup>D</sup></b>					
Nominal Salt Rejection %	98.5	98.5	98.5	98.5	98.5
Permeate Flow (gpm / lpm)	8.30 / 31.42	12.50 / 47.32	16.70 / 63.22	20.80 / 78.74	25.00 / 94.63
Minimum Feed Flow (gpm / lpm)	14.30 / 54.00	18.50 / 70.00	22.70 / 85.93	26.80 / 101.45	31.00 / 117.35
Maximum Feed Flow (gpm / lpm)	28 / 106	28 / 106	42 / 159	42 / 159	42 / 159
Minimum Concentrate Flow (gpm / lpm)	6.00 / 22.70	6.00 / 22.70	6.00 / 22.70	6.00 / 22.70	6.00 / 22.70
<b>Connections</b>					
Feed (in)	1.5 FNPT	1.5 FNPT	1.5 FNPT	1.5 FNPT	1.5 FNPT
Permeate (in)	1 FNPT	1 FNPT	1 FNPT	1.5 FNPT	1.5 FNPT
Concentrate (in)	1 FNPT	1 FNPT	1 FNPT	1.5 FNPT	1.5 FNPT
CIP (in)	1 FNPT	1 FNPT	1 FNPT	1 FNPT	1 FNPT
<b>Membranes</b>					
Membranes Per Vessel	2	2	2	2	2
Membrane Quantity	8	12	16	20	24
Membrane Size	4040	4040	4040	4040	4040
<b>Vessels</b>					
Vessel Array	2:2	2:2:2	3:3:2	3:3:2:2	3:3:2:2:2
Vessel Quantity	4	6	8	10	12
<b>Pumps</b>					
Pump Type	Multi-Stage	Multi-Stage	Multi-Stage	Multi-Stage	Multi-Stage
Motor HP	3	3	5	7.5	7.5
RPM @ 60Hz	3450	3450	3450	3450	3450
RPM @ 50Hz	2900	2900	2900	2900	2900
<b>System Electrical</b>					
Standard Voltage + Amp Draw	220V, 60Hz, 3PH, 9A <sup>E</sup>	220V, 60Hz, 3PH, 9A <sup>C</sup>	220V, 60Hz, 3PH, 14.2A <sup>C</sup>	220V, 60Hz, 3PH, 19.5A <sup>C</sup>	220V, 60Hz, 3PH, 19.5A <sup>C</sup>
High Voltage Service + Amp Draw	220V, 50Hz, 3PH, 10.6A <sup>E</sup> 460V, 60Hz, 3PH, 5A <sup>E</sup>	220V, 50Hz, 3PH, 10.6A <sup>E</sup> 460V, 60Hz, 3PH, 5A <sup>E</sup>	220V, 50Hz, 3PH, 16.1A <sup>E</sup> 460V, 60Hz, 3PH, 7A <sup>E</sup>	220V, 50Hz, 3PH, 22.9A <sup>E</sup> 460V, 60Hz, 3PH, 9.7A <sup>E</sup>	220V, 50Hz, 3PH, 22.9A <sup>E</sup> 460V, 60Hz, 3PH, 9.7A <sup>E</sup>
<b>System Dimensions</b>					
Approximate Dimensions <sup>F</sup> L x W x H (in / cm)	31 x 100 x 64 / 787.4 x 254 x 162.56	31 x 100 x 64 / 787.4 x 254 x 162.56	31 x 100 x 64 / 787.4 x 254 x 162.56	31 x 100 x 64 / 787.4 x 254 x 162.56	31 x 100 x 64 / 787.4 x 254 x 162.56
Approximate Weight (lbs / kg)	1060 / 480.81	1150 / 476.27	1260 / 571.53	1350 / 612.35	1450 / 657.71

**Test Parameters:** 550 TDS Filtered (5–Micron), Dechlorinated, Municipal Feedwater, 65 psi / 4.50 bar Feed Pressure, 80 psi / 5.5 bar Operating Pressure, 77°F / 25°C, Recovery as stated, 7.0 pH. Data taken after 60 minutes of operation.

C. Low temperatures and feedwater quality, such as high TDS levels will significantly affect the systems production capabilities and performance. Computer projections must be run for individual applications which do not meet or exceed minimum and maximum operating limits for such conditions.

D. Product flow and maximum recovery rates are based on feedwater conditions as stated above. Do not exceed recommended permeate flow.

E. Varies with motor manufacturer.

F. Does not include operating space requirements.

## OPERATING LIMITS<sup>G</sup>

Maximum Feed Temperature (°F / °C)	85 / 29	Maximum Turbidity (NTU)	1
Minimum Feed Temperature (°F / °C)	40 / 5	Maximum Free Chlorine (ppm)	0
Maximum Ambient Temperature (°F / °C)	120 / 49	Maximum TDS (ppm)	2,000
Minimum Ambient Temperature (°F / °C)	40 / 4	Maximum Hardness (gpg)	0
Maximum Feed Pressure (psi / bar)	85 / 6	Maximum pH (continuous)	11
Minimum Feed Pressure (psi / bar)	45 / 3	Minimum pH (continuous)	2
Maximum Operating Pressure (psi / bar)	200 / 14	Maximum pH (cleaning 30 minutes)	13
Maximum Feed Silt Density Index (SDI)	< 3	Minimum pH (cleaning 30 minutes)	1

G. System pressure is variable due to water conditions. Permeate flow will increase at a higher temperature and will decrease at a lower temperature.

800-320-4074

AXEONwater.com

