

E3-M FILTRATION SYSTEM

INTEGRATED BYPASS, METER &
DRAIN CONNECTION SYSTEM



The E3-M connection system is a metered option and is available to use with all POE (point-of-entry) filters.

EASY REPLACEMENTS NO TOOLS REQUIRED

1. PRESS THE RED PRESSURE RELIEF VALVE TO UNSEAT THE RING



2. REMOVE SNAP RING



3. LIFT TOP CAP



WATER CHEMISTRY AND LIMITATIONS

Free Chlorine: Up to 2 ppm

H2S: No limit

Iron, Ferrous: Up to 0.5 ppm

pH Range: 6–9

Flow Rates: Up to 10 gpm

Silica: < 35 mg/L

Hardness: Up to 500 ppm (29 gpg)

Temperature: 41–140 °F

Manganese: Up to 0.05 ppm

Copper: No limit

Total Suspended Solids: < 5 mg/L

Pre-filtration: 5 micron

Oil & Polyphosphates: Remove prior

Turbidity: 5 NTU

APPLICATIONS

Ideal for residential, food service, rental fleets, commercial and industrial applications

Make-up water, RO pre-filtration, cooling towers, chill water loops

Process water (turbidity, particulate, colloidal suspensions)

Reduction of unwanted bad taste and odor from potable drinking water

Reduction in frequency of replacing common 2½" or 4½" housings (bigger is better)

Other water-based fluid solutions

PIONEER[®] PF

PIONEER[®] PF FILTRATION CARTRIDGES

PIONEER[®] PF features a proprietary filtration solution for the water treatment industry specifically designed to remove PFAS forever chemicals from drinking water. Extremely user friendly with no hazardous waste streams or bulk media replacement, **PIONEER[®] PF** is proven to remove PFAS to non-detect levels (<1 ng/L). Additionally, spent cartridges will be returned to ENPRESS for PFAS extraction, destruction and media reuse—a first-of-its-kind technology and program!

PIONEER[®] PF provides molecular selectivity to both long- and short-chain PFAS (poly- and perfluoroalkyl) substances, whose adsorption is not affected by the co-presence of inorganic ions or other water characteristics like pH and TOC. The technology has greater than 25x adsorption capacity compared to GAC and IX resins that can be affected by biofouling. Like all adsorbents, suspended solids, iron and manganese should be removed in a pre-filtration step before water contact with PF8.

With no backwash requirement, low pressure drop, high treatment capacity, resistance to fouling, and a tiny footprint when used in the ENPRESS ONE E3-M[®] system, PIONEER[®] PF cartridges will provide filtration to non-detect for **eight** PFAS chemicals with service flow rates up to 10 gpm (37.9 lpm). For PFAS concentrations at 3,000+ ppt, the filter will provide non-detect levels of PFAS removal for greater than 150,000+ gallons of water. In more common water test results of 100 ppt, the expected life of a single cartridge is 350,000+ gallons of treated water.

The PIONEER[®] PF cartridge solution is ideal for small to medium size POE (point-of-entry) residential and light commercial water filtration installations, including RV parks, hotels, casinos and resorts, military bases, aquaculture, food processing, manufacturing plants, and multi-user wells of all sizes. The filter will remove to non-detect under these challenge conditions:

TESTING PARAMETERS—CONCENTRATION (NG/L)

PFHpA: 48.9

PFHxS: 419.0

PFOA: 557.7

PFOS: 1107.2

PFNA: 63.9

PFBS: 345.3

GenX: 987.0

PFDA: 12.4

Total: 3541.5

Performance Results: Non-Detect (<1 ng/L)

Lightweight and cost effective with multiple configuration options, from high flow commercial/industrial applications to stand-alone residential point-of-entry (POE) installations for city and well water applications, this is the filtration solution of the future—100% non-metallic!

For best results: use with pre- and post-filtration product solutions, including pleated filters (orange/yellow series) and carbon blocks (blue series).

TECHNICAL SCHEMATICS

PART IDENTIFICATION

- ONE E3-M Filtration System/Housing
- In/Out Head for 1.050" Riser Pipe
- 90 Degree Vertical Elbow With/without Machined Drain Port
- Flow Meter Assembly With Cord
- Meter Spacer Assembly
- Bypass Manifold
- 1" MNPT Straight Connector
- 1" MNPT 90 Degree Elbow Connector
- 3/8" PEX Drain Valve Kit Assembly With Shut-off
- PCB Umbrella With Electronics Non-WIFI, Version 1

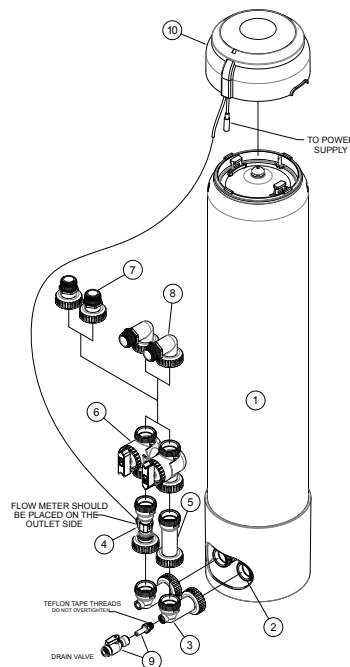



PIONEER® PF INTERNAL TESTING DATA

Internal testing to NSF/ANSI Standard 53 for PFAS reduction, with two filters challenged at a flow rate of 7 gpm (26.5 lpm) for 8 PFAS chemicals for a 50/50 testing cycle. A cocktail solution was made of the following PFAS in background free distilled water with an allowed variance of +/-10%. NSF/ANSI Standard 53 establishes minimum requirements for material safety, structural integrity, product literature, and health-related contaminant reduction performance claims.

Water Throughput (Gallons)	PFHpA (Influent)	PFOA (Influent)	PFNA (Influent)	PFDA (Influent)	PFBS (Influent)	PFHxS (Influent)	PFOS (Influent)	GenX (Influent)	Total (Influent)
350	36.3	380.7	41.5	9.6	230.0	294.7	787.6	634.8	2415.1
28000	38.9	487.7	55.0	9.5	267.5	283.3	844.2	684.1	2670.1
84000	35.2	415.8	50.2	9.7	261.9	306.9	816.1	735.1	2630.9
126000	54.5	371.3	43.1	8.9	246.1	295.5	838.3	628.2	2485.9
168000	45.5	305.8	37.4	7.3	198.4	234.9	676.6	550.3	2056.2

PIONEER® PF INTERNAL TESTING DATA—CHARTS

-  INFLUENT CHEMICAL(S)
-  CONCENTRATION (NG/L)
-  REMOVAL RESULT
-  THROUGHPUT (GAL)

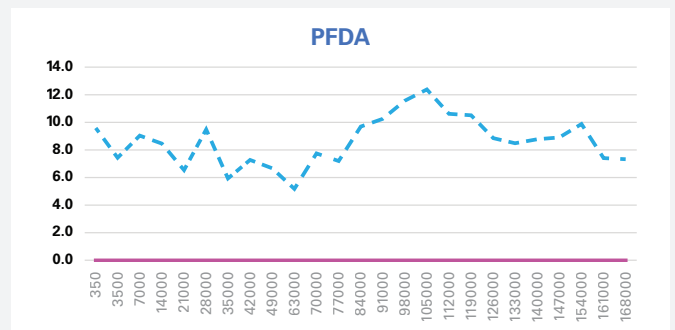
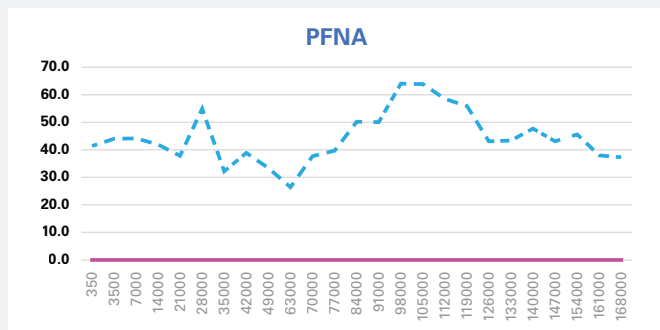
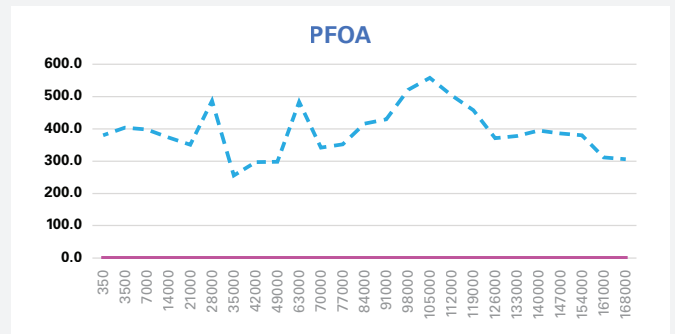
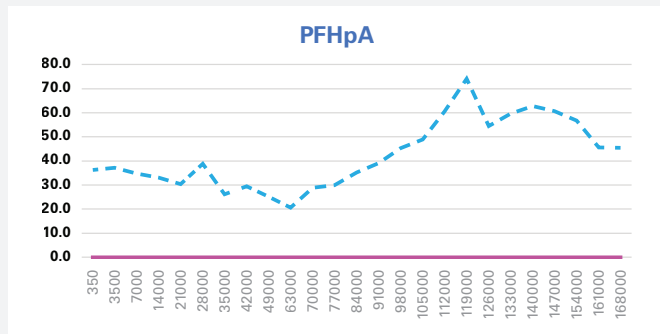
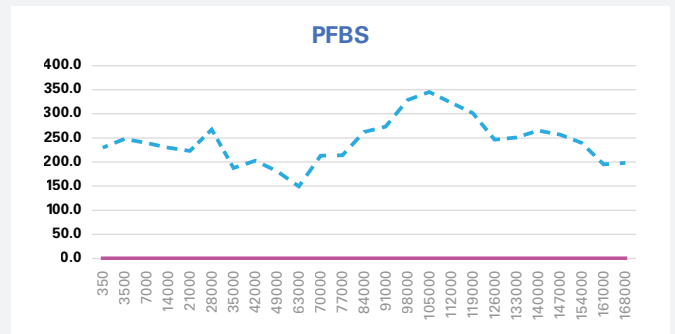

PIONEER® PF INTERNAL TESTING DATA—RESULTS

Test results to NSF/ANSI Standard 53 provided for PFAS removal to non-detect levels (<1 ng/L), and below the proposed EPA National Primary Drinking Water Regulation for PFOA and PFOS. The rule would set a Maximum Contaminant Level, or MCL, for all public water systems at 4 parts per trillion. MCLs are enforceable, regulatory levels.

[^]Note: EPA Health Advisory at 10 ppt.

Water Throughput (Gallons)	PFHpA	PFOA	PFNA	PFDA	PFBS	PFHxS	PFOS	GenX	Total
350	0.0	0.0	0.0	0.0	0.0	0.0	0.0	0.0	0.0
28000	0.0	0.0	0.0	0.0	0.0	0.0	0.0	0.0	0.0
84000	0.0	0.0	0.0	0.0	0.0	0.0	0.0	0.0	0.0
126000	0.0	0.0	0.0	0.0	0.0	0.0	0.0	2.3 [^]	2.3
168000	0.0	0.0	0.0	0.0	0.0	0.0	0.0	5.6 [^]	5.6

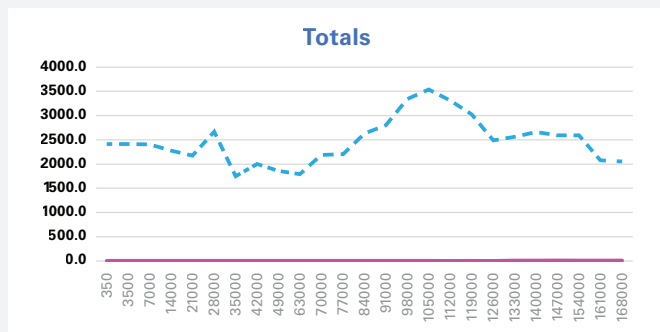
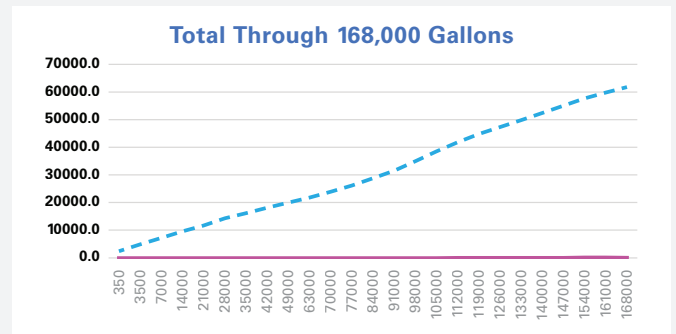
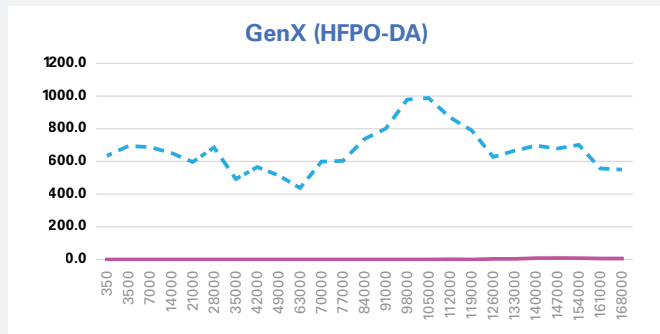
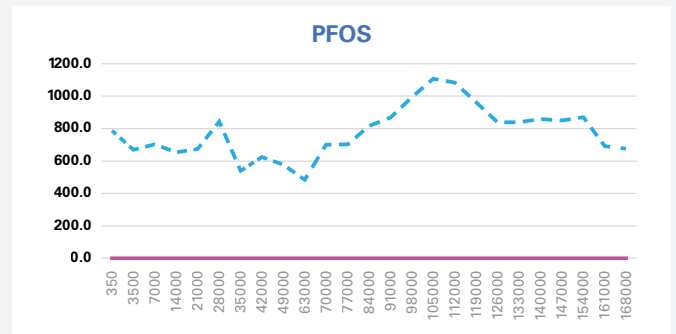
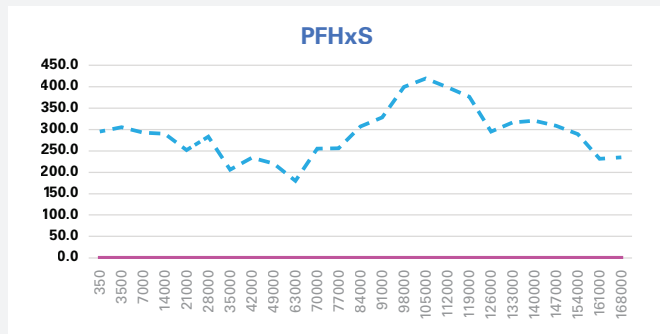

PIONEER® PF has superior characteristics, including rapid kinetics, high treatment capacity, resistance to fouling, regeneration, and an extended duty-cycle. PIONEER® PF has been proven to remove PFAS to non-detect levels.

For PFAS concentrations at 3000+ ppt, PIONEER® PF will provide non-detect levels of PFAS removal for up to 150,000+ gallons of water. In more common water test results of 100 ppt, the expected life of a single cartridge is 350,000+ gallons of treated PFAS-free water.

NOTE: Periodic testing of the treated water for PFAS is necessary to determine when the filter has reached its usable capacity for PFAS reduction.

Thank you for choosing PIONEER[®]

SPECIFICATIONS

ONE E3-M Name and Part Number	Size and Micron Rating	Rated Capacity and Flow Rate @ Challenge of 3100 ppt*	Rated Capacity and Flow Rate @ Challenge of 100 ppt*	Pressure Drop Spec
ONE E3-M System and PIONEER [®] PF Filter				
ONE E3-M System CTA0840BBKP5-06L00	8" x 40" / 20 Microns	PFAS Reduction 168,000+ Gallons @ 7 gpm 473,176 Liters @ 26.5 lpm @ 99.9% PFAS Reduction	PFAS Reduction 350,000+ Gallons @ 7 gpm 473,176 Liters @ 26.5 lpm @ 99.9% PFAS Reduction	9 psid @ 7 GPM (26.5 lpm)

PFAS chemicals removal cartridge with ATOMUS[®] PF8 inside // PART NUMBER: CT-5020-0640RD-PF8

*Claims are not performance tested by WQA, IAPMO or NSF. Performance claims are based on independent laboratory and manufacturer's internal test data. Actual performance is dependent on influent water quality, flow rates, system design and application. Results may vary. The model number of the system in which the filter component is to be used in is CTA0840BBKP5-06L00.



IMPORTANT

DO NOT USE extra lubricants, unapproved sealants and/or tools to tighten hand-tighten only parts. Use of tools other than hand-tighten only parts voids warranty. Testing was performed under standard laboratory conditions; actual performance may vary. Flush the system and change the filter as suggested. The contaminants or other substances removed or reduced by this water filter are not necessarily in all users' water.

PERFORMANCE

†Performance claims are based on independent lab results and manufacturer's internal test data. Actual performance is dependent on influent water quality, flow rates, system design and applications. Your results may vary. Micron ratings based on 85% or greater removal of a given particle size. Flush new cartridges TO DRAIN until water runs clear prior to use. Do not use with water that is microbiologically unsafe or of unknown quality without adequate disinfection before or after the system.

This system has been tested for the reduction of the substances listed below. The concentration of the indicated substances in water entering the system was reduced to a concentration less than equal to the permissible limit for water leaving the system, as specified in NSF/ANSI 53. Minimum substance reductions are as follows:

Substance	Influent Challenge Concentration (NG/L)	Maximum Permissible Product Water Concentration (NG/L)	NSF/ANSI Standard
PFAS	3100 +/- 10%	<1 ng/L	53

Minimum Operating Temperature: 34 °F / 1 °C
Maximum Operating Temperature: 120 °F / 50 °C
Minimum Operating Pressure: 20 psig / 1.38 bar
Maximum Operating Pressure: 125 psig / 8.6 bar
Electrical Requirements: Grounded and unswitched 115 V outlet and 3 AAA batteries

Filter Replacement Operating Instructions: New cartridges must be flushed for a minimum of 10 minutes prior to use. System and installation to comply with federal, state, and local laws and regulations. Do not use with water that is microbiologically unsafe or unknown quality without adequate disinfection before or after the system. Manufactured from NSF/ANSI standard 61 and California Prop 65 Compliant raw materials.

WARRANTY

LIMITED LIABILITY: ENPRESS LLC makes no warranties of any kind, expressed or implied, statutory or otherwise, and expressly disclaims all warranties of every kind concerning the product, including, without limitation, warranties of merchantability and fitness for a particular purpose, except that this product should be capable of performing as described in this product's data sheet. ENPRESS LLC's obligation shall be limited solely to the refund of the purchase price or replacement of the product proven defective, in ENPRESS LLC's sole discretion. Determination of suitability of this product for uses and applications contemplated by Buyer shall be the sole responsibility of Buyer. Use of this product constitutes Buyer's acceptance of this Limited Liability.

The ATOMUS[®] PF8 media inside this system is Certified by NSF International to NSF/ANSI 61 for Material Safety and NSF/ANSI 372 for Low Lead Content.

The E3 system is Certified by IAPMO R&T to NSF/ANSI 53 for Material Safety and NSF/ANSI 372 for Low Lead Content.

NOTES:

- Water conditions outside of the specified limits on front page may lead to a shortened filtration life.
- Cartridges may contain a very small amount of fines. After installation, flush the cartridges for at least 10 minutes prior to use.
- A ratio of 1:3 silica vs total hardness will maintain silica in solution and optimize performance.
- Adsorption is not affected by the co-presence of inorganic ions or other water characteristics like pH and TOC. Suspended solids should be removed in pre-filtration.
- Non-detect means <1 ng/L (1 ng/L = 1 ppt).
- Periodic testing of the treated water for PFAS is necessary to determine when the filter has reached its usable capacity for PFAS reduction.

System installation and cartridge disposal to comply with federal, state, and local laws and regulations.

FILTER PERFORMANCE[†]

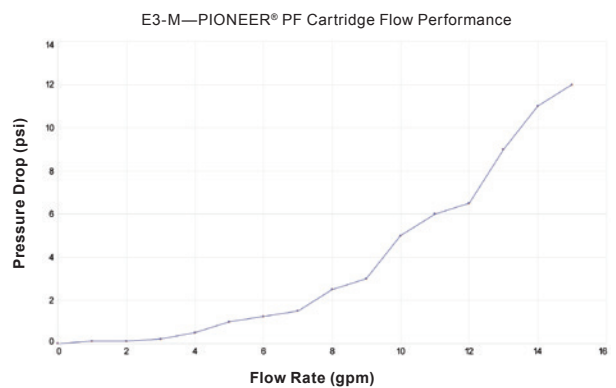

CERTIFICATIONS



The ENPRESS CTA0838BBxxP5-06Lyyy, CTA0840BBxxP5-06Lyyy and CTA0842BBxxP5-06Lyyy are certified by IAPMO R&T and WQA to NSF/ANSI 53 for Material Safety and Structural Integrity.

For more information, visit enpress.com or onefiltration.com

ENPRESS, LLC. // 34899 Curtis Blvd., Eastlake Ohio 44095 // Phone: 866.859.9274 // Fax: 440.510.0202 // info@enpress.com

ENPRESS[®], ONE[®], E3-M[®], PIONEER[®], Cartridge Tank[™], ATOMUS[®] AND UMBRELLA CAP[®] are trademarks of ENPRESS, LLC. US and International patents, and patent pending. © ENPRESS LLC 2023 | ONE[®] is an ENPRESS Filtration Technology | 12/2023